

Taiwan Bicycle Industry Standard

TBIS

4210-4

Second edition

2017.01.01

**Cycles — Safety requirements for
bicycles —**

Part 4:

Braking test methods

Reference number:
ISO 4210-4:2014

Contents

Page

Foreword	iii
Introduction	v
1 Scope	1
2 Normative references	1
3 Terms and definitions	1
4 Test methods	1
4.1 Brake lever grip dimensions	1
4.2 Brake levers — Position of applied force	5
4.3 Brake-block and brake-pad assemblies — Security test	7
4.4 Hand-operated braking-system — Strength test	7
4.5 Back-pedal braking system — Strength test	7
4.6 Braking performance	8
4.7 Brakes — Heat-resistance test	25
Annex A (informative) Explanation of the method of least squares for obtaining the line of best fit and $\pm 20\%$ limit lines for braking performance linearity	26
Annex B (normative) Brake performance — endurance test	29
Bibliography	30

All rights reserved
Reprints must investigate

Foreword

Taiwan Bicycle Industry Standard (TBIS) is approved and announced by Taiwan Bicycle Association (TBA). The preparatory work of "Taiwan Bicycle Industry Standard" is carried out by the technical expert committee from TBIS. When TBA members are interested in the related standard that has been announced, and after they are approved by the R&D and patent committee of TBA, they will become the member of the technical expert committee of TBIS. TBA and Cycling & Health Tech Industry R&D Center (CHC) are in close cooperation to handle all matters applied and established by TBIS.

The structure, establishing process and revising of this standard should be proposed to and get determined by the R&D and Patent Committee of TBA. This standard is implemented after the announcement of TBA. Please be aware, some part of this document may involve patent rights. TBIS has no legal obligation to mark out where all or part of the patent is involved.

All rights reserved
Reprints must investigate

Background description:

After 2015, The International Organization for Standardization 4210: 2014 (ISO 4210:2014) will be the most commonly used safety standard in global bicycle industry. Although ISO 4210 is not a mandatory inspection standard in various economic markets, they are still requesting their bicycle products suppliers to follow the basis of ISO 4210 safety requirements. However, this phenomenon represents that they are unable to differentiate the quality and grade differences between bicycles and spare parts. In order to keep up the competitiveness of our bicycle industry in the international market, the technical expert committee of TBIS uses ISO 4210 as their investigation basis and propose a higher level of product safety and standard service, to establish TBIS especially for this purpose. To highlight on the quality, performance and reliability of those components that has passed TBIS inspection, which have already exceeded the international standard. In the meantime, TBIS is developing on the safety standard and testing technology on those bicycle parts that are excluded in ISO 4210, to ensure the product and identify the differences between product performance, which has become an important reference to drive the improvement on Taiwan bicycle industry Research & Design units.

Establishment History

- 1st: [TBIS General Meeting (rev. NP) Discussion] Total 13 companies and 18 industry experts participate, 2015.06.25.
- 2nd: [TBIS Working Draft (rev. WD) Discussion] Total 13 companies and 18 industry experts participate, 2015.06.25.
- 3rd: [TBIS Committee Draft (rev. CD) Discussion] Total 14 companies and 22 industry experts participate, 2015.07.21.
- 4th: [TBIS Enquiry stage (rev. DTS) Discussion] Total 15 companies and 19 industry experts participate, 2015.09.02.
- 5th: [TBIS Approval Stage (rev. FDTS) Discussion] Total 17 companies and 19 industry experts participate, 2015.10.28.
- 6th: [TBIS Subject Meeting] Total 17 companies and 19 industry experts participate, 2015.10.28.
- 7th: [TBIS Enquiry stage (rev. DTS) Discussion] Total 20 companies and 21 industry experts participate, 2016.04.22.
- 8th: [TBIS Approval Stage (rev. FDTS) Discussion] Total 18 companies and 18 industry experts participate, 2016.06.24.
- 9th: [TBIS Subject Meeting] Total 15 companies and 16 industry experts participate, 2016.11.04.

Introduction

The purpose of this TBIS is to build the world's leading bicycle industry standards and norms bicycle manufacturing process to ensure product safety and external benefits effectively (including announcing internationally, producing high-valued products, and leading the R&D of bicycle industry, etc.), highlighting the product inspected by TBIS is in compliance with a higher safety requirement. While riding the bicycle on public roads, the laws and regulations of the country will be applicable.

TBIS 4210 consists of the following parts, under the general title *Cycles — Safety requirements for bicycles*:

- *Part 1: Terms and definitions*
- *Part 2: Requirements for city and trekking, young adult, mountain and racing bicycles*
- *Part 3: Common test methods*
- *Part 4: Braking test methods*
- *Part 5: Steering test methods*
- *Part 6: Frame and fork test methods*
- *Part 7: Wheels and rims test methods*
- *Part 8: Pedals and drive system test methods*
- *Part 9: Saddles and seat-post test methods*

Reference

The following documents, in whole or in part, are normatively referenced in this document and are indispensable for its application. For dated references, only the edition cited applies. For undated references, the latest edition of the referenced document (including any amendments) applies.

- ISO 4210-1, *Cycles — Safety requirements for bicycles — Part 1: Terms and definitions*
- ISO 4210-3:2014, *Cycles — Safety requirements for bicycles — Part 3: Common test methods*
- ISO 4210-4:2014, *Cycles — Safety requirements for bicycles — Part 4: Braking test methods*
- ISO 4210-5:2014, *Cycles — Safety requirements for bicycles — Part 5: Steering test methods*
- ISO 4210-6:2015, *Cycles — Safety requirements for bicycles — Part 6: Frame and fork test methods*
- ISO 4210-7:2014, *Cycles — Safety requirements for bicycles — Part 7: Wheel and rim test methods*
- ISO 4210-8:2014, *Cycles — Safety requirements for bicycles — Part 8: Pedal and drive system test methods*
- ISO 4210-9:2014, *Cycles — Safety requirements for bicycles — Part 9: Saddle and seat-post test methods*
- ISO 5775-1, *Bicycle tyres and rims — Part 1: Tyre designations and dimensions*
- ISO 5775-2, *Bicycle tyres and rims — Part 2: Rims*

Modify TBIS 4210-4:2017 as follows:

Annex B (normative) Brake performance — endurance test

*All rights reserved
Reprints must investigate*

Cycles — Safety requirements for bicycles —

Part 4: Braking test methods

1 Scope

This part of TBIS 4210 specifies the braking test methods for TBIS 4210-2.

2 Normative references

The following referenced documents, in whole or in part, are normatively referenced in this document and are indispensable for its application. For dated references, only the edition cited applies. For undated references, the latest edition of the referenced document (including any amendments) applies.

TBIS 4210-1:2016, *Cycles — Safety requirements for bicycles — Part 1: Terms and definitions*

TBIS 4210-2:2017, *Cycles — Safety requirements for bicycles — Part 2: Requirements for city & trekking, young adult, mountain and racing bicycles*

3 Terms and definitions

For the purposes of this document, the terms and definitions given in TBIS 4210-1:2016 apply.

4 Test methods

4.1 Brake lever grip dimensions

4.1.1 Test method for the brake lever similar to type A or type B

Fit the gauge illustrated in [Figure 1](#) over the handlebar grip or the handlebar (when the manufacturer does not fit a grip) and the brake lever as shown in [Figure 2](#), so that face A is in contact with the handlebar or grip and the side of the brake lever. Ensure that face B spans an area of that part of the brake lever which is intended for contact with the rider's fingers without the gauge causing any movement of the brake lever towards the handlebar or grip. Measure the distance, a , the distance between the last part of the lever intended for contact with the rider's fingers and the end of the lever. The measurement should be conducted only on a fully assembled bicycle.

Dimensions in millimetres

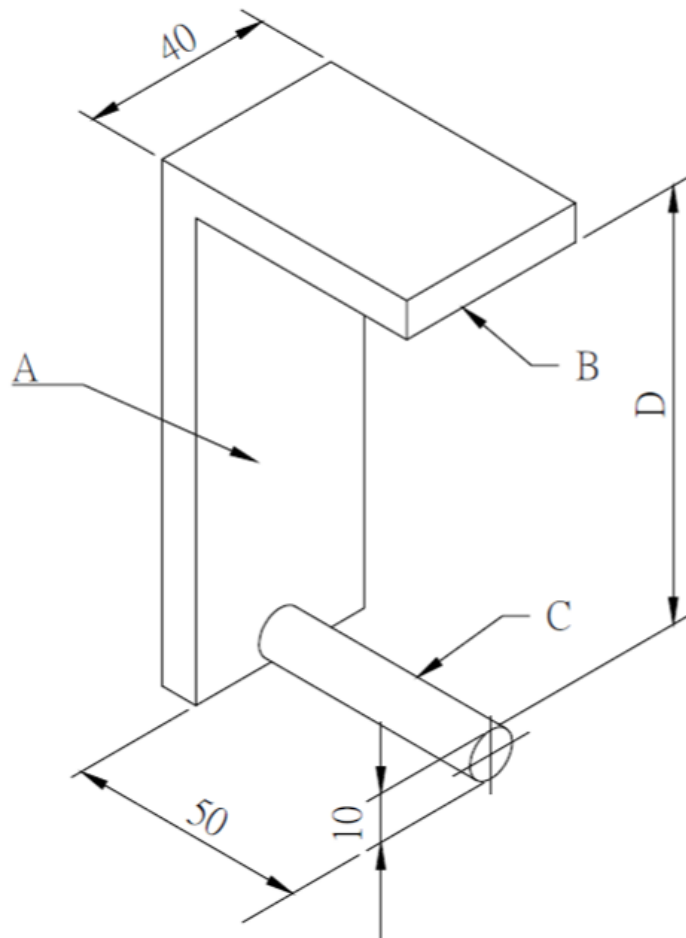

Key

- A face A
- B face B
- C rod
- D 75 mm or 90 mm

Figure 1 — Brake lever grip dimension gauge for type A and type B

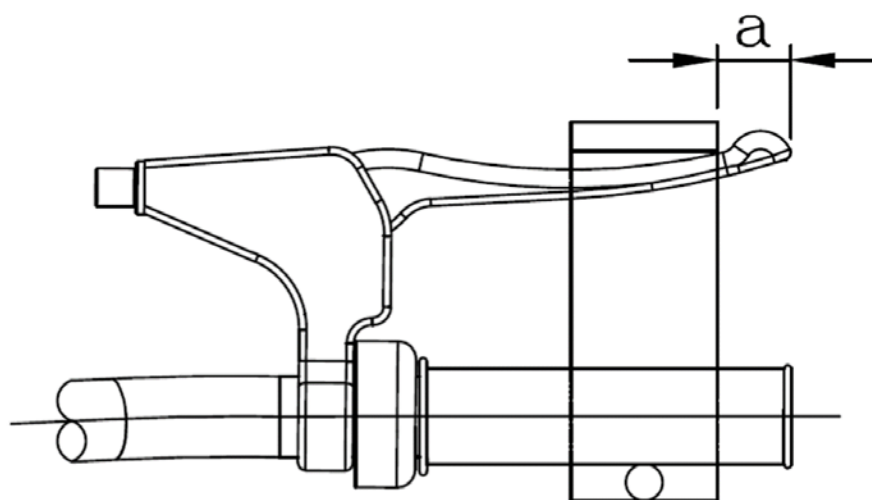

a) Type A

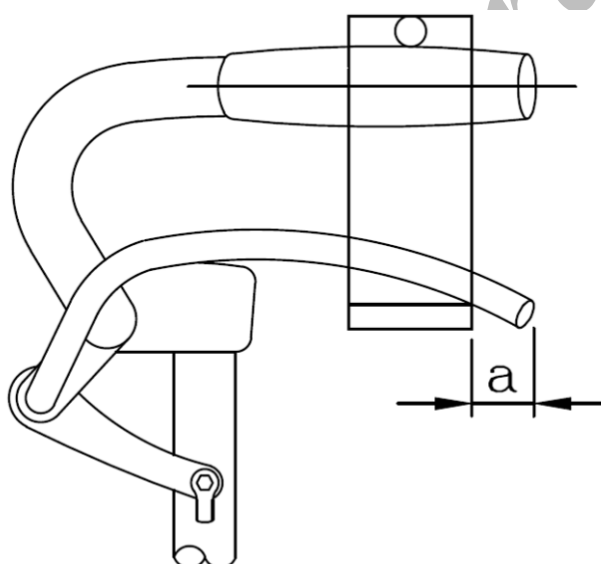

b) Type B

NOTE Minimum grip length is shown.

Figure 2 — Method of fitting the gauge to the brake lever and handlebar

4.1.2 Test method for the brake lever similar to type C

Fit the gauge illustrated in [Figure 3](#) over the handlebar and brake lever as shown in [Figure 4](#) so that face A is in contact with the handlebar or handlebar grip and the brake lever. Put the face of cylinder B in

contact with the part of the grip intended for contact with the rider's hand and check if the requirements are met.

Dimensions in millimetres

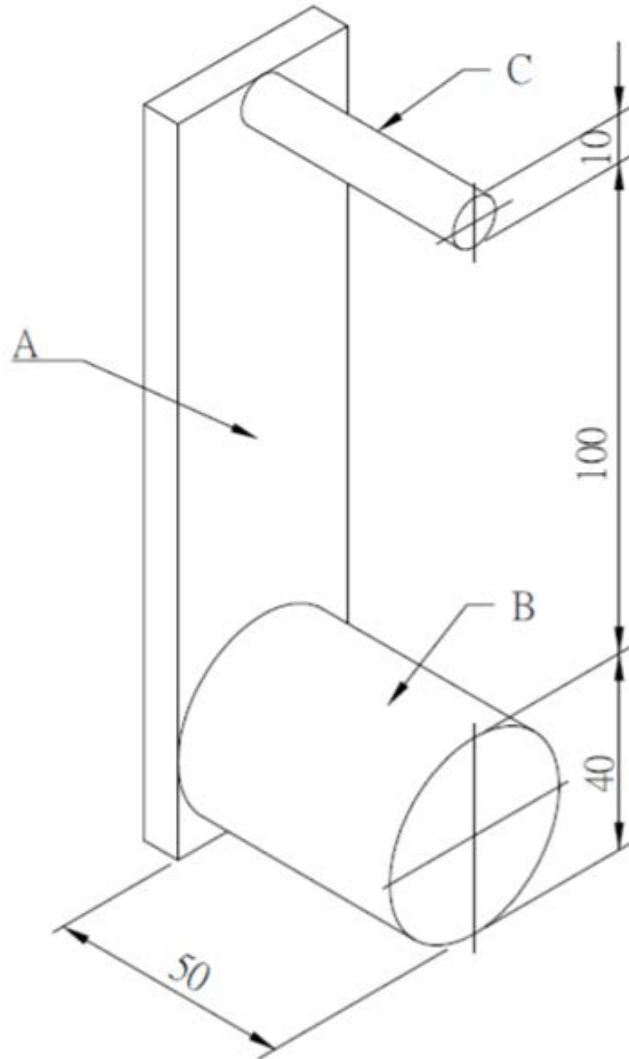

Key

- A face A
- B face of cylinder
- C rod

Figure 3 — Brake lever grip-dimension gauge for type C

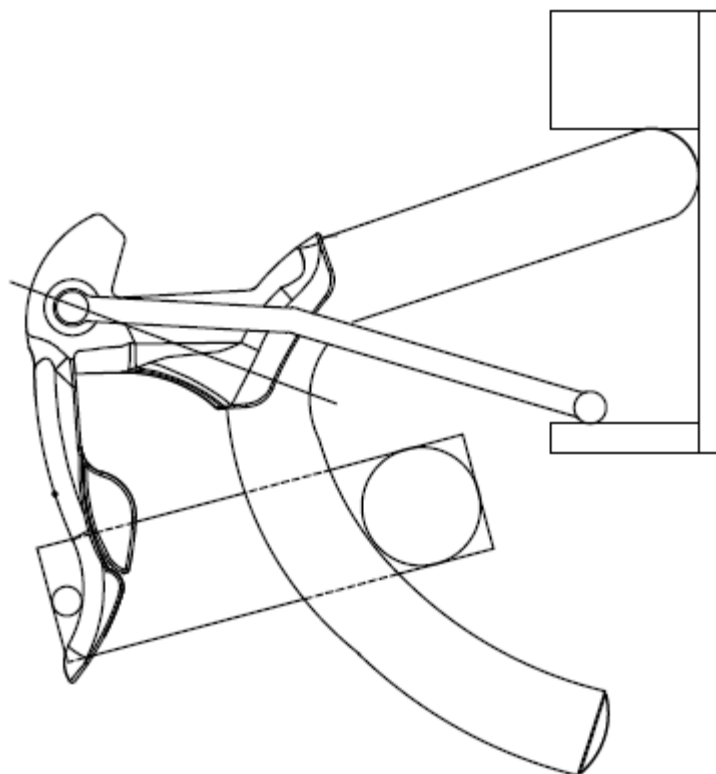

Figure 4 — Method of fitting the gauge to the brake lever and handlebar for type C

4.2 Brake levers — Position of applied force

4.2.1 Type A and B brake levers

For the purposes of braking tests in this part of TBIS 4210, for brake levers similar to type A or type B, the test force shall be applied at a distance b , which is equal to either dimension a [see TBIS 4210-2:2017, Figure 2 a) and b)] as determined in [4.1.1](#) or 25 mm from the free end of the brake lever, whichever is the greater [see [Figure 5 a\)](#) and [Figure 5 b\)](#)].

4.2.2 Type C brake levers

For the purposes of braking tests in this part of TBIS 4210, for brake levers similar to type C, the test force shall be applied at a distance of 25 mm from the free end of the brake lever [see [Figure 5 c](#)].

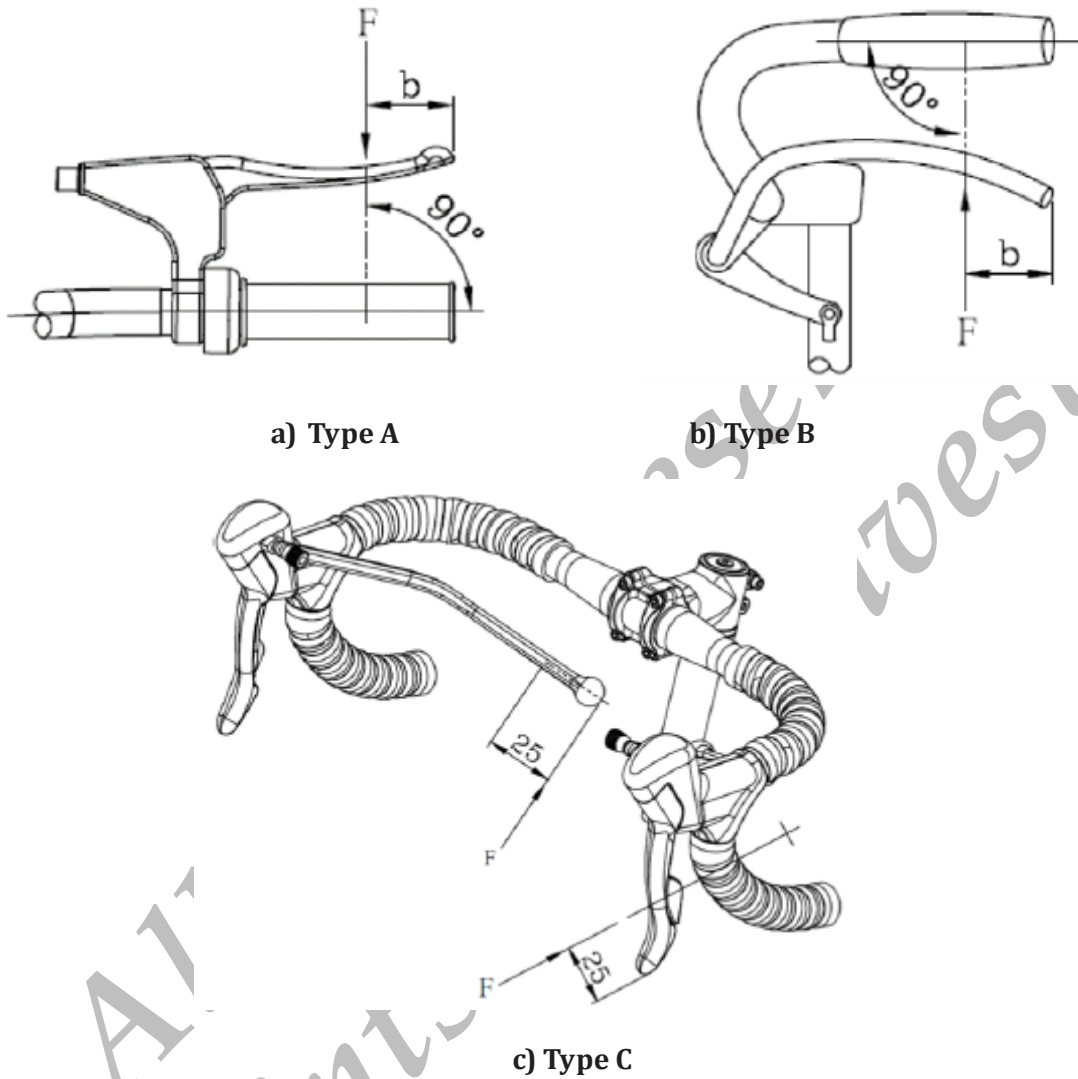

Key
 F applied force
 $b \geq 25 \text{ mm}$

Figure 5 — Position of applied force on the brake lever

4.3 Brake-block and brake-pad assemblies — Security test

Conduct the test on a fully assembled bicycle with the brakes adjusted to a correct position with a rider or equivalent mass on the saddle. The combined mass of the bicycle and rider (or equivalent mass) shall be 100 kg.

Actuate each brake lever with a force of 180 N applied at the point specified in [Figure 5](#) or a force sufficient to bring the brake lever into contact with the handlebar grip, whichever is lesser. Maintain this force while subjecting the bicycle to five forward and five rearward movements, each of which is not less than 75 mm distance.

Then conduct the test described in [4.4](#) or [4.5](#) as appropriate, depending on the style of brake, and then the test described in [4.6](#).

4.4 Hand-operated braking-system — Strength test

Conduct the test on a fully assembled bicycle. After it has been ensured that the braking system is adjusted according to the recommendations in the manufacturer's instructions, apply a force to the brake lever at the point specified in [Figure 5](#). This force shall be 450 N, or such lesser force as is required to bring

- a) a brake lever into contact with the handlebar grip or the handlebar where the manufacturer does not fit a grip,
- b) a brake extension lever level with the surface of the handlebar or in contact with the handlebar, and
- c) a secondary brake lever to the end of its travel.

Repeat the test 10 times on each brake lever, secondary brake lever, or extension lever.

4.5 Back-pedal braking system — Strength test

Conduct the test on a fully assembled bicycle. After it has been ensured that the braking system is correctly adjusted, and with the pedal cranks in a horizontal position, as shown in [Figure 6](#), apply a vertically downward force to the centre of the left-hand pedal spindle. Increase the force progressively to 1 500 N and maintain fully for 1 min.

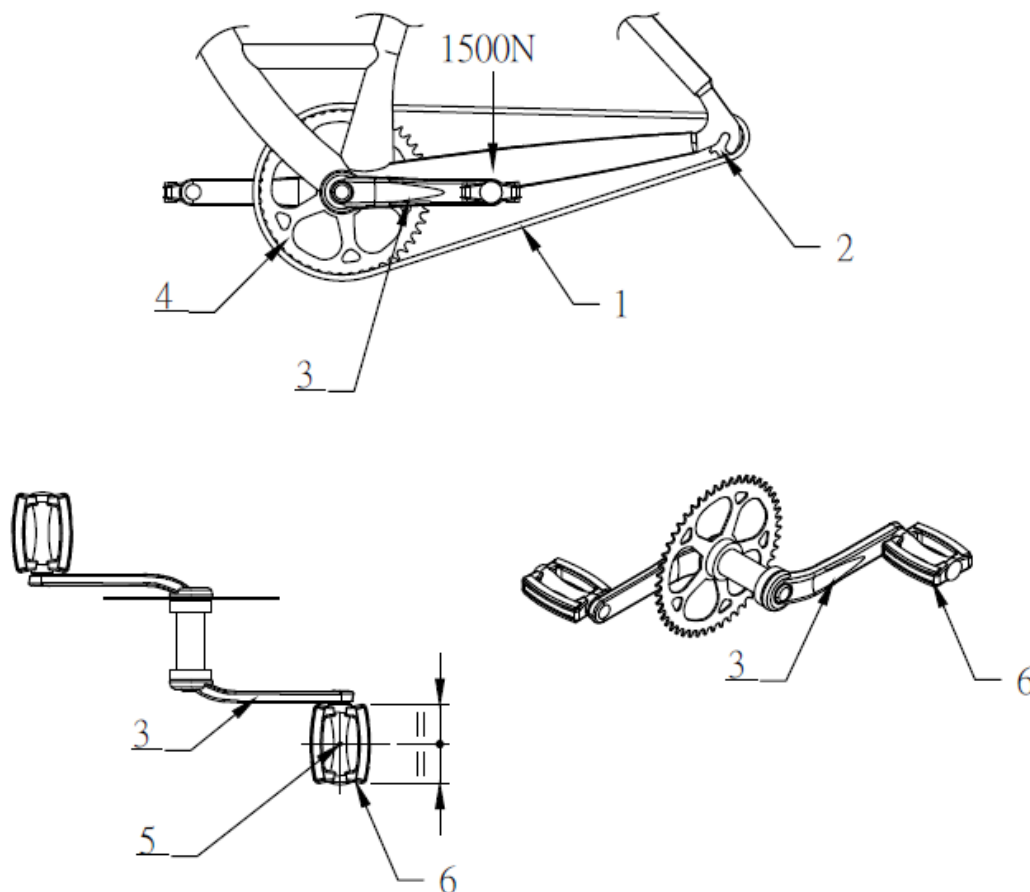

- Key**
- 1 chain
 - 2 hub sprocket
 - 3 non-drive side crank
 - 4 cycle chain wheel and pedal crank
 - 5 point of force application
 - 6 pedal

Figure 6 — Back-pedal brake test

4.6 Braking performance

4.6.1 Test bicycle

Conduct the braking performance test on a fully assembled bicycle after the brakes have been subjected to the strength test detailed in TBIS 4210-2:2017, 4.6.6, and 4.6.7. Before testing the bicycle by either method, inflate the tyres and adjust the brakes according to the manufacturer’s instructions. In the case of rim-brakes, adjust it to the maximum clearance specified by the manufacturer.

4.6.2 Secondary brake levers

Where a bicycle is fitted with secondary brake levers attached to brake levers, bar-ends, or aerodynamic extensions, separate tests shall be conducted for the operation of the secondary brake levers in addition to tests with the normal levers.

4.6.3 Track test method

4.6.3.1 Test track

- a) Use an indoor test track if possible. If an outdoor test track is used, pay special attention to ambient conditions throughout the test.
- b) The gradient of the track shall not exceed 0,5 %. If the gradient is less than 0,2 % carry out all runs in the same direction. If the gradient lies between 0,2 % and 0,5 %, carry out alternate runs in opposite directions.
- c) The surface shall be hard, of concrete or fine asphalt, and free from loose dirt or gravel. The minimum coefficient of friction between the dry surface and the bicycle tyre shall be 0,75.
- d) The track shall be essentially dry at the commencement of tests. When testing to the requirements of [4.6.3.6](#), the track shall remain dry throughout the tests.
- e) The wind speed on the track shall not exceed 3 m/s during the tests.

4.6.3.2 Instrumentation

The test bicycle or the test track shall be instrumented to include the following:

- a) a calibrated speedometer or tachometer (accurate to within $\pm 5\%$) to indicate to the rider the approximate speed at the commencement of braking;
- b) a velocity-recording device (accurate to within $\pm 2\%$) to record the velocity at the commencement of braking;
- c) a distance recording system (accurate to within $\pm 1\%$) to record the braking distance;
- d) a water spray system, to provide wetting of the braking surface, consisting of a water reservoir connected by tubing to a pair of nozzles at the front wheel and a pair of nozzles at the rear wheel. A quick-acting on/off valve shall be included for control by the rider. Each nozzle shall provide a flow of water at ambient temperature of not less than 4 ml/s. Details of the positions and directions of nozzles for rim brakes, hub brakes, band brakes, disc brakes, and back-pedal brake are given in [Figures 7 to 13](#);
 NOTE [Figures 7 and 8](#) for rim brakes show side-pull callipers but the same arrangements apply to centre-pull callipers and cantilever brakes.
- e) a brake-actuation indicating system to record independently when each lever or pedal is actuated.

4.6.3.3 Mass of bicycle, rider, and instrumentation

The combined mass of the bicycle, the rider, and the instrumentation shall be 100 kg.

When wet condition braking tests are performed, the combined mass can decrease throughout the test due to water consumption, but it shall not be less than 99 kg at the end of the valid test runs.

Where a manufacturer specifies that their bicycle can carry a mass such that the sum of that mass plus the mass of the bicycle is in excess of 100 kg (60 kg for young adults) to some value M , apply M as total weight.

Any extra weight shall be positioned above the rear wheel and in front of the rear axle.

4.6.3.4 Force applied to the brake levers

- a) Magnitude and position of force on brake levers

Apply a handgrip force not exceeding 180 N at the point as specified in [Figure 5](#). Check before and after each series of test runs to verify the lever force.

b) Optional brake-force application device

It is permissible to use a test mechanism to operate the brake lever, and when such a device is used, it shall meet the requirements of [4.6.3.4](#) item a) and shall additionally control the rate of application of the brake lever force such that 63 % of the intended lever force is applied in not less than 0,2 s.

4.6.3.5 Running — in the braking surfaces

A running-in process shall be conducted on every brake before performance testing is carried out.

Apply the brakes for not less than 3 s to maintain steady deceleration while the bicycle is being ridden at a speed of approximately 16 km/h. Repeat this operation 10 times.

4.6.3.6 Test method — Test runs under dry conditions

Pedal the test bicycle until the specified test velocity is attained. Then stop pedalling and apply the brakes. The bicycle shall be brought to a smooth, safe stop

4.6.3.7 Test method — Test runs under wet conditions

The method shall be as given in [4.6.3.6](#), with the addition that wetting of the brake system(s) shall commence not less than 25 m prior to the commencement of braking and shall continue until the bicycle comes to rest. Excessive amounts of water can be swept from the test track surface between runs.

4.6.3.8 Number of valid test runs

- a) If the gradient of the track is less than 0,2 %, the following runs shall be made:
- 1) five consecutive valid runs under dry conditions;
 - 2) two acclimatization runs under wet conditions (results not recorded);
 - 3) five consecutive valid runs under wet conditions.
- b) If the gradient of the track lies between 0,2 % and 0,5 %, the following runs shall be made:
- 1) six consecutive valid runs under dry conditions with alternate runs in opposite directions;
 - 2) two acclimatization runs under wet conditions (results not recorded);
 - 3) six consecutive valid runs under wet conditions with alternate runs in opposite directions.

A rest period not exceeding 3 min can be taken between successive runs.

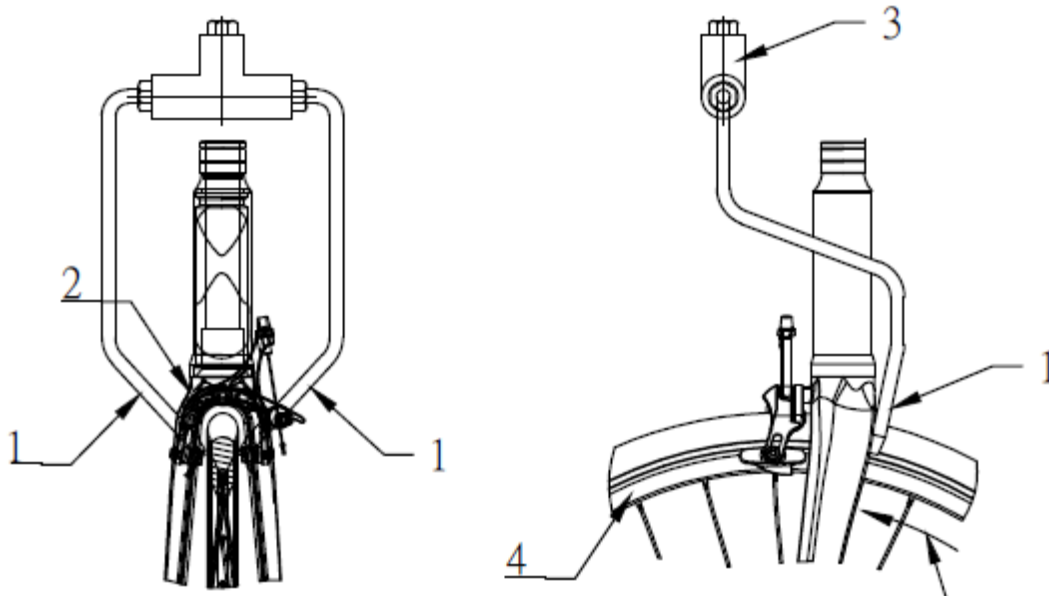

Key

- 1 water nozzles
- 2 fork crown
- 3 front tee-piece
- 4 wheel rim
- 5 direction of the wheel rotation

Figure 7 — Water nozzles for rim-brake (front)

All rights reserved. Reprints must invoice gate

Dimensions in millimetres

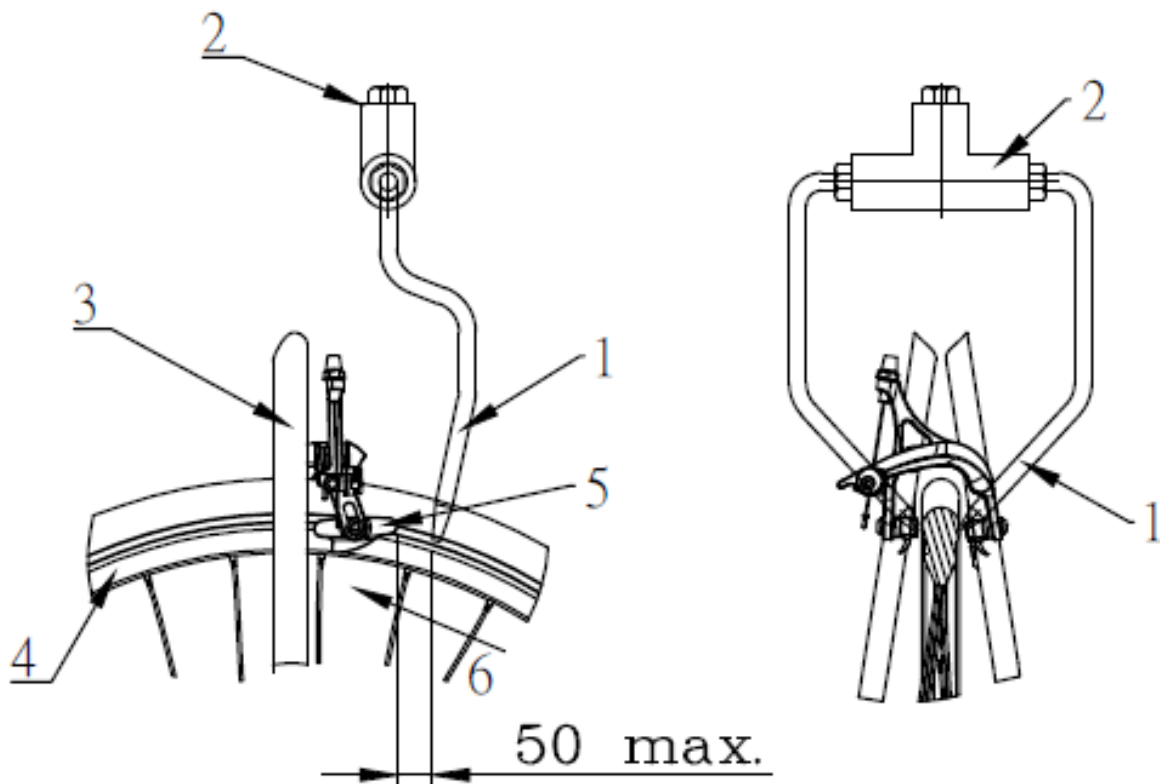

Key

- 1 water nozzles
- 2 rear tee-piece
- 3 bicycle frame
- 4 wheel rim
- 5 brake assembly
- 6 direction of the wheel rotation

Figure 8 — Water nozzles for rim-brake (rear)

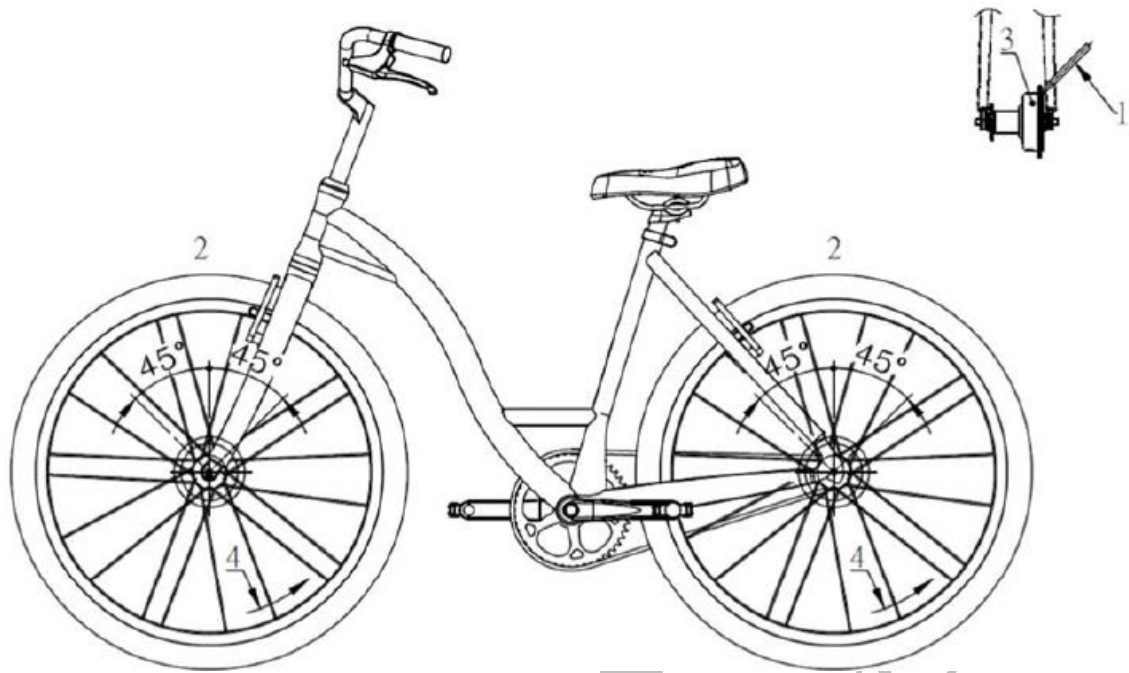

Key

- 1 water nozzle
- 2 two water nozzles
- 3 hub brake
- 4 direction of the wheel rotation

Figure 9 — Water nozzles for hub-brake

All rights reserved
Reprints must invoice

Dimensions in millimetres

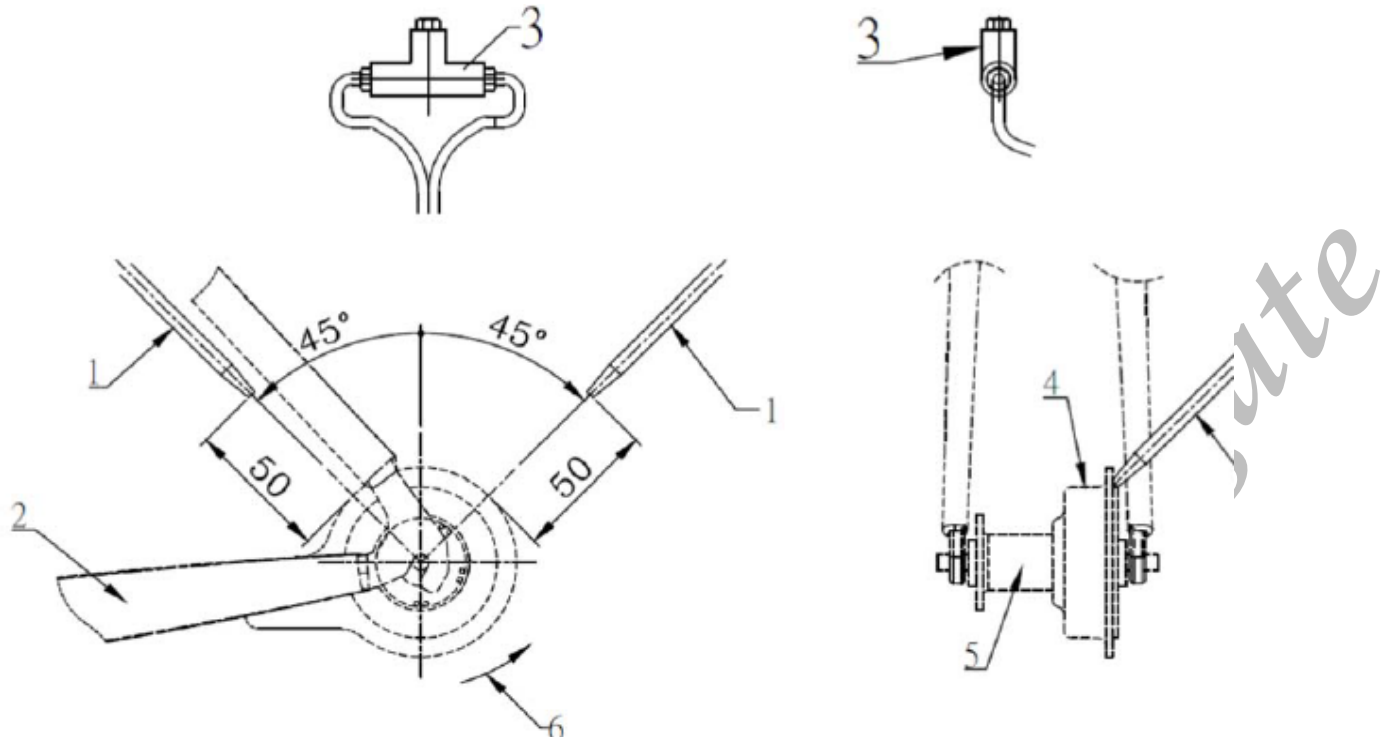

Key

- 1 water nozzle
- 2 bicycle frame
- 3 rear tee-piece
- 4 band brake
- 5 rear hub
- 6 direction of the wheel rotation

Figure 10 — Water nozzles for band-brake

Dimensions in millimetres

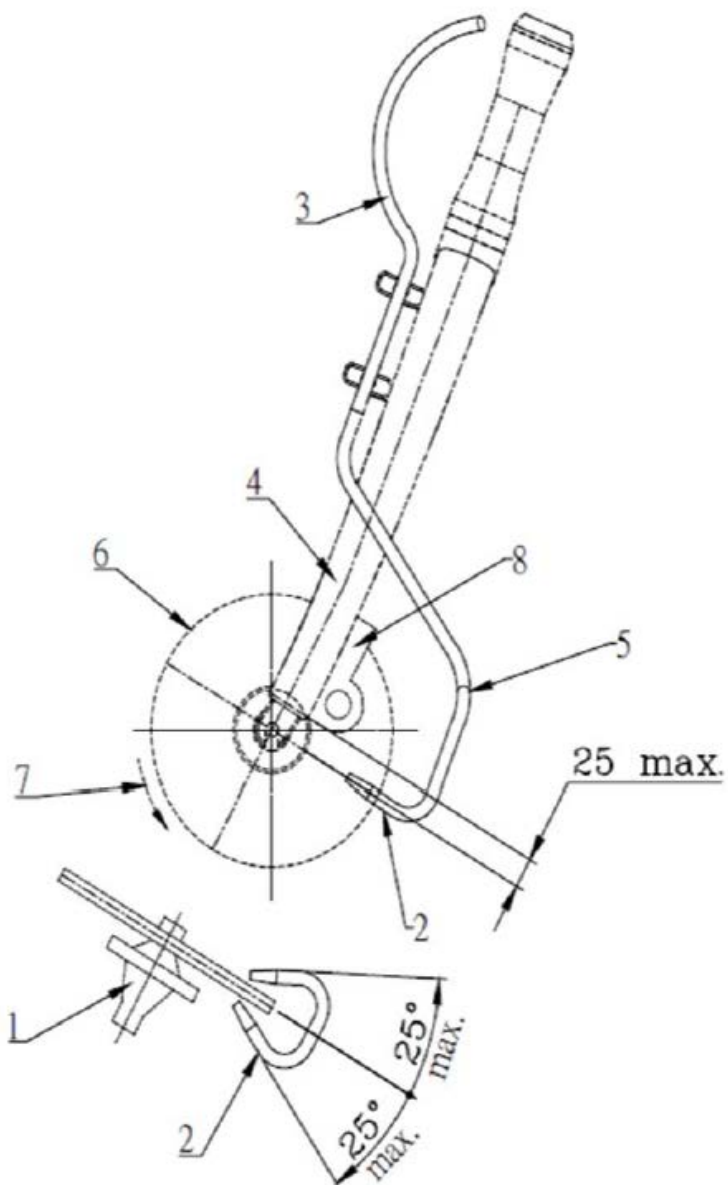

Key

- 1 front hub
- 2 water nozzles
- 3 flexible pipe
- 4 suspension-fork leg
- 5 Y-joint
- 6 brake-disc
- 7 direction of the wheel rotation
- 8 disc-brake calliper

Figure 11 — Water nozzles for disc-brake (front)

Dimensions in millimetres

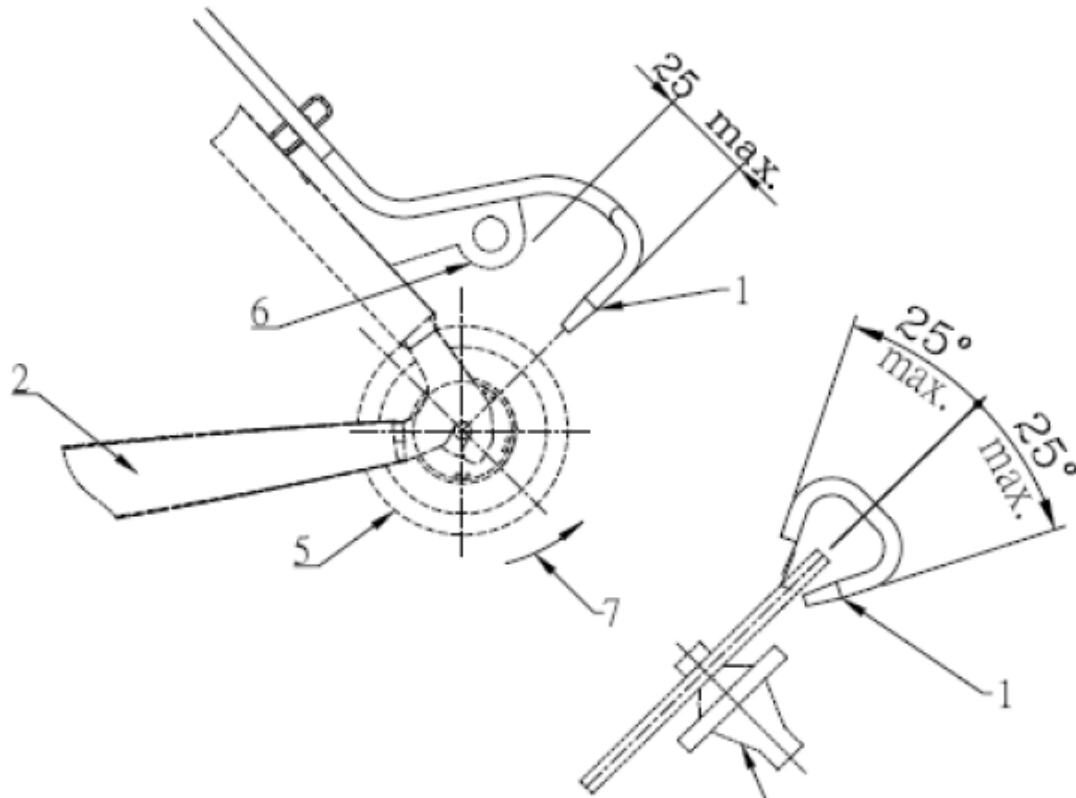

Key

- 1 water nozzles
- 2 bicycle frame
- 3 rear hub
- 4 Y-joint
- 5 brake disc
- 6 disc-brake calliper
- 7 direction of the wheel rotation

Figure 12 — Water nozzles for disc-brake (rear)

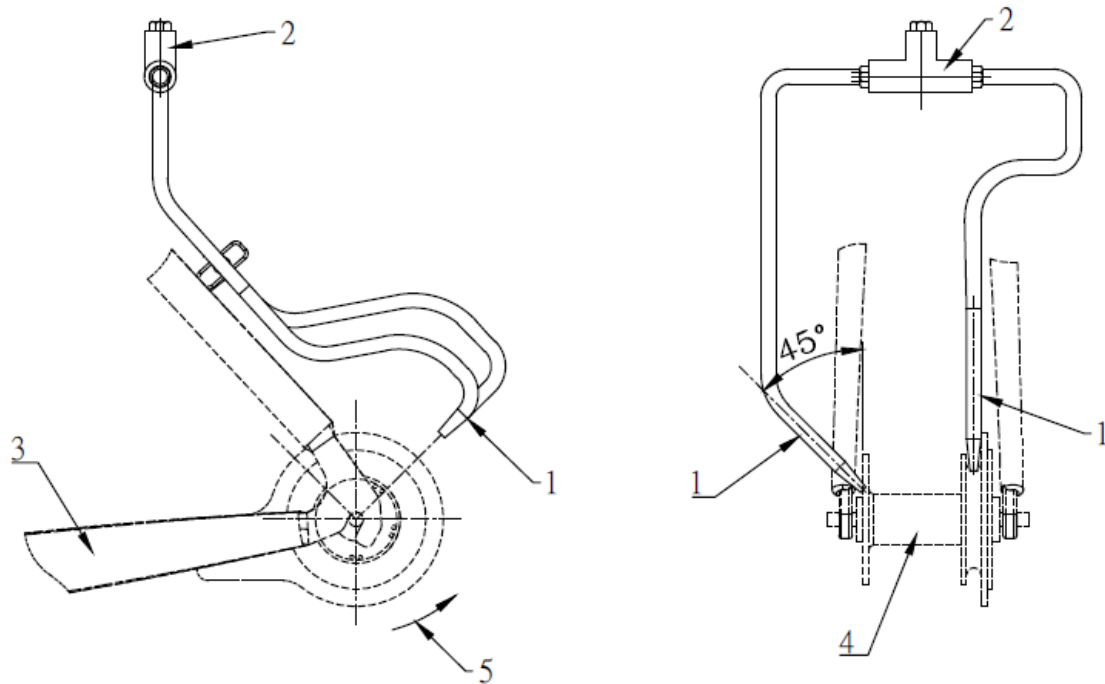
**Key**

- 1 water nozzles
- 2 rear tee-piece
- 3 bicycle frame
- 4 brake hub
- 5 direction of the wheel rotation

Figure 13 — Water nozzles for back-pedal brake

4.6.3.9 Velocity/distance correction factor

A correction factor shall be applied to the measured braking distance if the velocity as checked by the timing device is not precisely as specified in TBIS 4210-2:2016, 4.6.8.1.1.

The corrected braking distance shall be determined from Formula (1):

$$S_c = \left(\frac{V_s}{V_m} \right)^2 \times S \quad (1)$$

where

S_c is the corrected braking distance (m);

S_m is the measured braking distance (m);

V_s is the specified test velocity (m/s);

V_m is the measured test velocity (m/s).

4.6.3.10 Validity of test runs

- a) A test run shall be considered invalid if
 - 1) excessive side-skid causing the rider to put his foot to the ground to retain control occurs, or
 - 2) loss of control occurs.

With certain types of braking system, it might not be possible to avoid entirely some skidding of the rear wheel during braking. This is considered acceptable provided that 1) or 2) above do not occur as a result.

- b) If the corrected braking distance exceeds the braking distance specified in TBIS 4210-2:2017, Table 2, a test run shall be considered invalid if the velocity at the commencement of the test exceeds the specified test velocity by more than 1,5 km/h as specified in TBIS 4210-2:2017, Table 2.
- c) If the corrected braking distance is less than the braking distance specified in TBIS 4210-2:2017, Table 2, a test run shall be considered invalid if the velocity at the commencement of braking is more than 1,5 km/h below the specified test velocity.

If the corrected braking distance exceeds the braking distance specified in TBIS 4210-2:2017, Table 2, the test run shall be considered valid.

4.6.3.11 Test results

- a) Braking under dry conditions

Depending on the gradient of the test track, the test result shall be the average value of the corrected braking distance (see 4.6.3.9) of the test results of either 4.6.3.8 item a) 1) or 4.6.3.8 item b) 1).

For compliance with the requirements of TBIS 4210-2:2017, 4.6.8.1.1 the above average values shall not exceed the relevant braking distances specified in TBIS 4210-2:2017, Table 2.

- b) Braking under wet conditions

Depending on the gradient of the test track, the test result shall be the average value of the corrected braking distances (see 4.6.3.9) of the test results of either 4.6.3.8 item a) 3) or 4.6.3.8 item b) 3).

For compliance with the requirements of TBIS 4210-2:2017, 4.6.8.1.1, the above average values shall not exceed the relevant braking distances specified in TBIS 4210-2:2017, Table 2.

- c) Ratio between wet and dry braking performance for city and trekking, young adult, mountain and disc brake racing bicycles.

Because the wet and dry braking distances are measured at different test velocities, a simple comparison of braking distances is not meaningful. Therefore, a comparison shall be made of equivalent, calculated values, using Formula (2):

$$\frac{16^2}{S_c^W} : \frac{25^2}{S_c^D} \tag{2}$$

where

S_c^D is the corrected braking distance in dry conditions (m);

S_c^W is the corrected braking distance in wet conditions (m).

4.6.4 Back-pedal brake linearity test

This test shall be conducted on a fully assembled bicycle. The output force for a back-pedal brake shall be measured tangentially to the circumference of the rear tyre, when the wheel is rotated in the direction of forward movement, while a force of between 90 N and 300 N is being applied to the pedal at right angles to the crank and in the direction of braking.

The braking force reading shall be taken during a steady pull and after one revolution of the wheel. A minimum of five results, each at a different pedal force level, shall be taken. Each result shall be the average of three individual readings at the same load level.

The results shall be plotted on a graph, showing the line of best fit and the $\pm 20\%$ limit lines obtained by the method of least squares outlined in [Annex A](#).

4.6.5 Machine test method

4.6.5.1 General

The test machine enables the braking distances for both brakes or the rear brake alone to be calculated from measurements of the individual braking forces of the front and rear brakes on a drum or belt.

4.6.5.2 Symbols

F_{Op}	Operating force (i.e. force applied on brake lever or pedal)
$F_{Op\ intend}$	Intended operating force (e.g. 40 N, 60 N, 80 N etc.)
$F_{Op\ rec}$	Recorded operating force (e.g. 38 N, 61 N, 79 N etc.)
F_{Br}	Braking force
$F_{Br\ rec}$	Recorded braking force
$F_{Br\ corr}$	Corrected braking force (Corrected for difference between $F_{Op\ intend}$ and $F_{Op\ rec}$)
$F_{Br\ average}$	Arithmetic mean of the three $F_{Br\ corr}$ at one level of $F_{Op\ intend}$
$F_{Br\ max}$	Maximum $F_{Br\ average}$
$F_{D_{Br}}$	Dry braking force
$F_{W_{Br}}$	Wet braking force

4.6.5.3 Linearity

When tested by the methods described in [4.6.5.7](#) item c) 1) and 2), the braking force $F_{Br\ average}$ shall be linearly proportional (mountain and racing bicycle are within $\pm 10\%$, city and young adult bicycles are within $\pm 20\%$) to the progressively increasing intended operating forces $F_{Op\ intend}$. The requirement applies to braking forces $F_{Br\ average}$ equal to and greater than 80 N (see [Annex A](#)).

4.6.5.4 Test machine

The test machine shall incorporate a system that drives the wheel during the test by tyre contact and a means of measuring the braking force, and typical examples of two types of machine are illustrated in [Figures 14](#) and [15](#).

[Figure 14](#) shows a machine in which a roller drives the individual wheels, and [Figure 15](#) shows a machine in which a driven belt contacts both wheels. Other types of machine are permitted, provided they meet the specific requirements listed below and those specified in [4.6.5.5](#) and [4.6.5.6](#).

The specific requirements are as follows:

- a) the linear surface velocity of the tyre shall be 12,5 km/h and shall be controlled within $\pm 5 \%$;
- b) a means of laterally restraining the wheel under test shall be provided which does not influence the measurement of braking force;
- c) a means of laterally applying forces to the brake levers at the point specified in [Figure 5](#) shall be provided, with the width of the contact on the lever not greater than 5 mm. In the case of back-pedal brakes, a means of applying forces to a pedal is also required.

4.6.5.5 Instrumentation

The test machine shall be instrumented to include the following:

- a) a device to record the surface velocity of the tyre, accurate to within $\pm 2 \%$;
- b) a device to record the braking force (see [Figures 14](#) and [15](#), for example), accurate to within $\pm 5 \%$;
- c) a device to record the operating force applied to the hand lever or pedal, accurate to within $\pm 1 \%$;
- d) a water spray system, to provide wetting of the brakes of the bicycle, consisting of a water reservoir connected by tubing to a pair of nozzles arranged as shown in [Figure 16](#). Each nozzle shall provide a flow of water at ambient temperature of not less than 4 ml/s. The wheel shall be suitably enclosed to ensure that, in addition to the rim, any hub- or disc-brake is thoroughly wetted before a test begins;
- e) a system for loading the wheels of the bicycle against the driving mechanism (see [4.6.5.6](#)).

Dimensions in millimetres

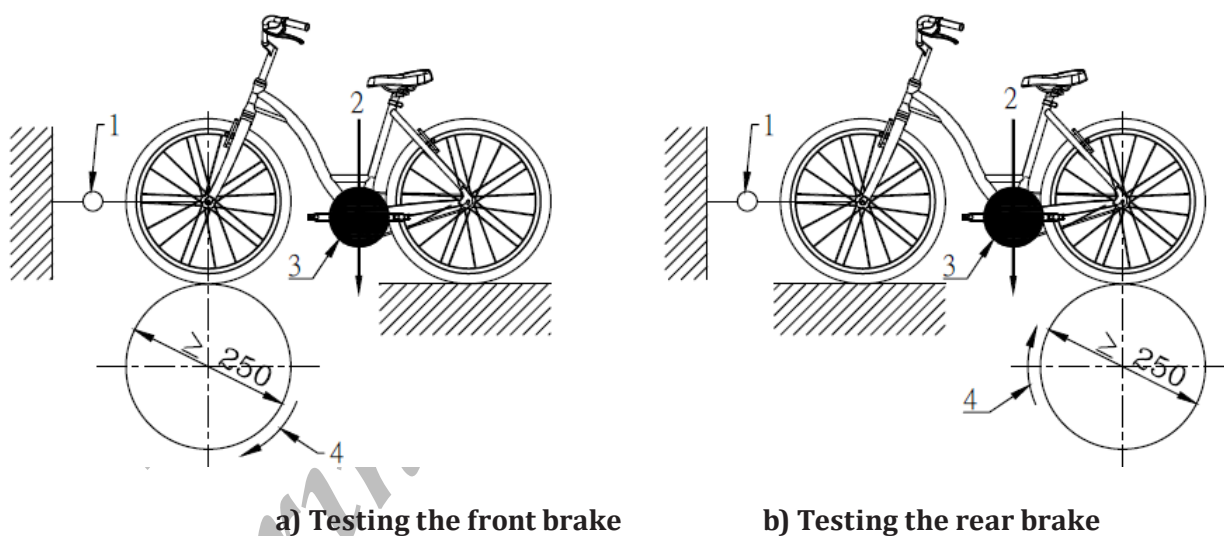

- Key**
- 1 braking force transducer
 - 2 applied force
 - 3 additional mass
 - 4 direction of drum rotation

Figure 14 — Braking performance test machine — Single drum type

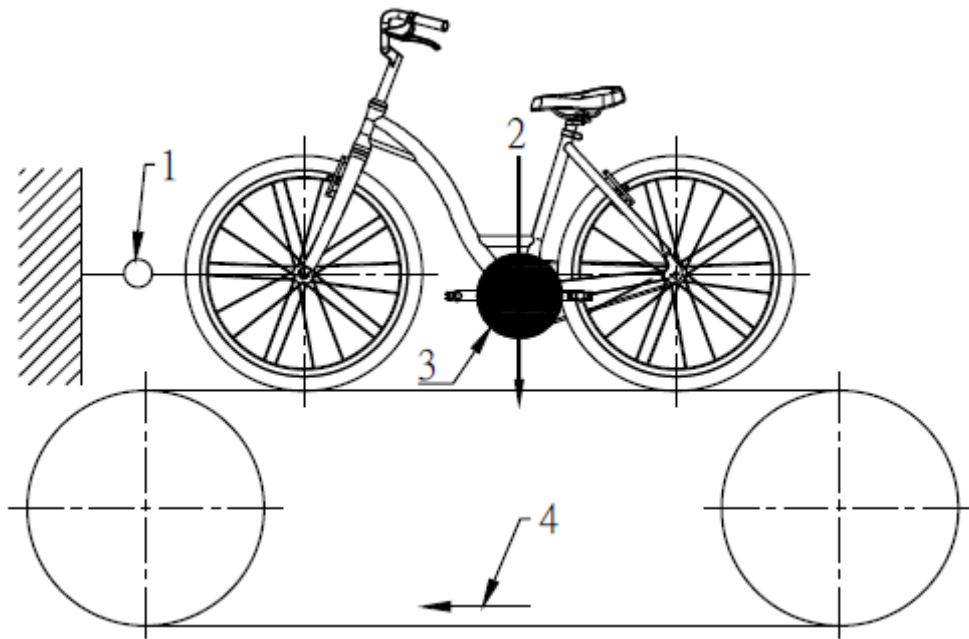
**Key**

- 1 braking force transducer
- 2 applied force
- 3 additional mass
- 4 direction of belt travel

Figure 15 — Braking performance test machine — Driven belt type

All rights reserved.
Reprints must inquire. gate

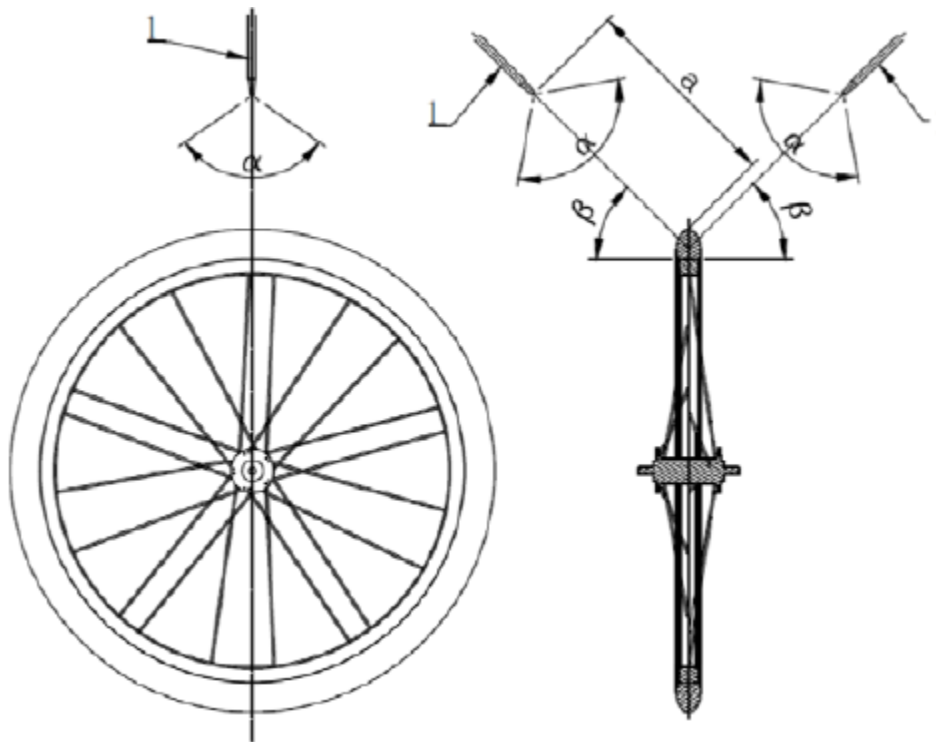

Key

- α 90° to 120°
- β 30° to 60°
- a 150 mm to 200 mm
- 1 water nozzles

NOTE Applicable to all types of brake.

Figure 16 — Water nozzle arrangement for the wet braking test

4.6.5.6 Vertical force on the tested wheel

The wheel to be tested shall be forced vertically downwards so that no skidding of the wheel occurs when tested according to 4.6.5.7 item c) 1) and 2). The necessary force can be applied anywhere on the bicycle (wheel axle, bottom bracket, seat-post, etc.) provided that it is exerted vertically downwards.

4.6.5.7 Test method

a) General

Test the front and rear wheels individually.

b) Running-in the braking surfaces

Conduct a running-in process on every brake before the performance test is performed.

In order to determine the operating force to be used during the running-in process, mount and load the bicycle on the test machine with the belt or drum running at the specified speed and apply an operating force to the brake lever or the pedal that is high enough to achieve a braking force

of $200 \text{ N} \pm 10 \%$. Maintain this operating force for at least 2,5 s, and note the value of the applied operating force.

Repeat the procedure (applying the operating force determined in the paragraph above accurate to within $\pm 5 \%$) 10 times, or with more repetitions if necessary, until the mean braking force from anyone of the three latest tests does not deviate by more than $\pm 10 \%$ from the mean braking force from these same three tests.

c) The performance tests

1) Testing under dry conditions

For hand-operated brakes, with a vertical force applied to the bicycle sufficient to prevent skidding of the tyre on the wheel under test, accelerate the driving mechanism to the specified velocity, then apply the operating force in a series of 20 N increments from 40 N to either 180 N (in case of young adult bicycles, apply to 120 N) or to the force necessary to achieve a braking force of at least 700 N, whichever is the lesser. However, if the wheel locks, if any possible brake-overload device is actuated, or if the hand lever comes into contact with the handlebar, do not increase the force further. For each increment of applied operating force, perform three tests within 1 min. Before applying the next level of operating force, allow the brake to cool for 1 min.

For back-pedal brakes, with a vertical force applied to the bicycle sufficient to prevent skidding of the tyre on the wheel under test, accelerate the driving mechanism to the specified velocity, then apply the operating force in a series of 50 N increments from 100 N to either 350 N or to the force necessary to achieve a braking force of at least 400 N, whichever is the lesser. However, if the wheel locks, if any possible brake-overload device is actuated, do not increase the force further. For each increment of applied operating force, perform three tests within 1 min. Before applying the next level of operating force, allow the brake to cool for 1 min.

The applied operating forces shall lie within $\pm 10 \%$ of the intended operating forces, shall be applied as specified in [Figures 5 and 6](#) and [4.6.5.4](#) item c), shall be recorded with an accuracy of $\pm 1 \%$, and shall be fully applied within 1,0 s of the commencement of braking.

For each increment of operating force, record the braking force value, $F_{\text{Br rec}}$, for a period of between 2,0 s and 2,5 s, with measurement starting 0,5 s to 1,0 s after the commencement of braking. Record $F_{\text{Br rec}}$ as the average braking force during this measurement period.

The time at which the measurement of the braking force is started shall be related to the speed at which the operating force is applied. If the operating force is fully applied in less than 0,5 s after the commencement of braking, start the measurement after 0,5 s. However, if the operating force is fully applied between 0,5 s and 1,0 s after the commencement of braking, start the measurement when the operating force is fully applied.

2) Testing under wet conditions

The method shall be as given in [4.6.5.7](#) item c) 1) with the addition that wetting of the brake system shall commence not less than 5,0 s before the commencement of braking and shall continue until the measurement period has ended.

Water nozzles shall be arranged according to [Figure 16](#).

d) Correction of braking force

Each recorded braking force, $F_{\text{Br rec}}$, shall be corrected for any difference between the recorded operating force and the intended operating force. The corrected braking force shall be calculated by multiplying the recorded braking force, $F_{\text{Br rec}}$, with a correction factor which is the ratio between the intended operating force, $F_{\text{Op intend}}$, and the recorded operating force, $F_{\text{Op rec}}$.

EXAMPLE Recorded braking force $F_{\text{Br rec}} = 225 \text{ N}$

Intended operating force $F_{\text{Op intend}} = 180 \text{ N}$

Recorded operating force $F_{Op\ rec} = 184\ N$

Correction factor = $180/184$

Corrected braking force $F_{Br\ corr} = 225 \times (180/184)$

e) Test results

Select from the record the maximum output braking force, $F_{Br\ max}$, for each combination of wheel (front or rear) and each test condition (wet or dry).

The braking performance value shall be calculated using Formula (3):

$$B_p = F_{Br\ max} \times \frac{m}{M} \quad (3)$$

where

B_p is the braking performance value (N);

$F_{Br\ max}$ is the maximum $F_{Br\ average}$ (N);

m is the standard mass of the bicycle defined as 100 kg for adult bicycle and 60 kg for young adult bicycle (kg);

M is the maximum permissible total mass specified by the manufacturer in TBIS 4210-2, Clause 5 item h) (kg).

Where a manufacturer specifies that his bicycle can carry a mass such that the sum of that mass plus the mass of the bicycle is in excess of 100 kg (60 kg for young adults) to some value M, apply M as total weight.

f) Linearity

Plot the calculated $F_{Br\ average}$ values (the arithmetic mean of the three corrected braking forces at each level of operating force) against the equivalent operating force values, $F_{Op\ intend}$, in order to assess the linearity against the requirement in 4.6.5.3. Plot the results on a graph, showing the line of best fit and the $\pm 10\ %$ for mountain and racing bicycle, others are $\pm 20\ %$ limit lines obtained by the method of least squares outlined in Annex A.

g) Ratio between wet and dry braking for city and trekking, young adult, and mountain bicycles, and racing bicycle in disc brake system

For any operating force (F_{Op}) for which the measured dry braking force ($F_{Br\ average}^D$) is greater than 200 N, the ratio between the measured braking force in wet conditions ($F_{Br\ average}^W$) and the measured braking force in dry conditions ($F_{Br\ average}^D$) shall be greater than 50 %.

For each F_{Op} where $F_{Br\ average}^D$ is $> 200\ N$, determine] whether or not the requirements of have been met using Formula (4):

$$F_{Br\ average}^W : F_{Br\ average}^D \quad (4)$$

For symbols see 4.6.5.2.

h) Simple track test (see TBIS 4210-2:2017, 4.19)

After completion of the machine test, conduct a brief, simple track test with progressively increasing operating forces to determine whether or not the brakes bring the bicycle to a smooth, safe stop.

NOTE This test can be combined with the test on the fully assembled bicycle.

4.7 Brakes — Heat-resistance test

Drive the wheel and tyre assembly with the brake applied on a machine such as those described in [4.6.5.5](#) at a velocity of 12,5 km/h \pm 5 % with a rearward, cooling air-velocity of 12,5 km/h \pm 10 %, so that a total braking energy of E Wh \pm 5 % specified in [Table 1](#) is developed. The duration of the test shall be 15 min \pm 2 min.

Allow the brake to cool to ambient temperature and then repeat the test cycle.

A maximum of 10 interruptions per test cycle is permitted, each with a maximum duration of 10 s.

When the test has been carried out, subject the brakes to the applicable parts of the tests described in [4.6.5.7](#) item c) 1) and 2).

Calculate the braking energy from Formula (5):

$$E = F_{Br} \times V_{Br} \times T \text{ (Wh)} \quad (5)$$

where

F_{Br} is the braking force (N);

V_{Br} is the linear velocity of the periphery of the tyre (i.e. 12,5 km/h = 3,472 m/s) (m/s);

T is the duration of each test cycle (excluding interruptions) (i.e. 15 min = 0,25 h) (h).

Table 1 — Total braking energy

Bicycle type	City and trekking bicycles	Young adult bicycles	Mountain bicycles	Racing bicycles
Total braking energy, E Wh	55	55	75	75

When the test has been carried out, the brakes shall be subjected to the applicable parts of the test described in [4.6.5](#), in order to check that the requirement in TBIS 4210-2:2017, 4.6.9.2 is fulfilled.

Annex A (informative)

Explanation of the method of least squares for obtaining the line of best fit and ±20 % limit lines for braking performance linearity

The readings taken in the test specified in 4.6.5.7 can be expected to lie near some straight line that can be drawn through them. Although in practice one might draw a good straight line through the points by eye, the method of least squares given here provides a criterion for minimizing the discrepancies and permits a line to be selected that has a claim to be called the best fit.

The line of best fit is the line that minimizes the sum of the squares of the differences between the observed results and the corresponding results predicted by the line.

The relationship between the variables is considered to be of the form

$$y = a + bx \tag{A.1}$$

where

x is the independent variable, and is known precisely (in this case, the load applied to the pedal);

y is the dependent variable, and is observed but with a degree of uncertainty (in this case, the braking force at the wheel).

a and b are unknown constants and have to be estimated.

For a series of n readings, this relationship can be resolved by taking a minimum of the sum of the squares of the difference to give

$$b = \frac{n \sum xy - \sum x \sum y}{n \sum x^2 - \sum x \sum x} \tag{A.2}$$

Taking $y = \frac{\sum y}{n}$ and $x = \frac{\sum x}{n}$ (A.3)

$$b = \frac{\sum xy - \bar{y} \sum x}{\sum x^2 - \bar{x} \sum x} \quad (\text{A.4})$$

Then a can be found by substitution:

$$a = \bar{y} - b\bar{x} \quad (\text{A.5})$$

For example, the following four values of x and y are noted during a test, from which $\sum xy$, $\sum x^2$, \bar{x} and \bar{y} are calculated as shown:

No.	x (pedal force) N	y (braking force) N
1	90	90
2	150	120
3	230	160
4	300	220
Sum	$\sum x = 770$	$\sum y = 590$
Mean	$\bar{x} = 192,5$	$\bar{y} = 147,5$

No.	xy	x^2
1	8 100	8 100
2	18 000	22 500
3	36 800	52 900
4	66 000	90 000
Sum	$\sum xy = 128 900$	$\sum x^2 = 173 500$

$$b = \frac{\sum xy - \bar{y} \sum x}{\sum x^2 - \bar{x} \sum x}$$

$$= \frac{128\,900 - (147,5 \times 770)}{173\,500 - (192,5 \times 770)}$$

$$= 0,606$$

$$a = \bar{y} - b\bar{x}$$

$$= 147,5 - (0,606 \times 192,5)$$

$$= 30,8$$

The line of best fit is therefore

$$y = 30,8 + 0,60x$$

and the $\pm 20\%$ limit lines are

$$y_{\text{lower}} = \frac{80}{100} (30,8 + 0,606x)$$

$$= 24,64 + 0,485x$$

$$y_{\text{upper}} = \frac{120}{100} (30,8 + 0,606x)$$

$$= 36,96 + 0,727x$$

The results from the example are shown graphically in [Figure A.1](#).

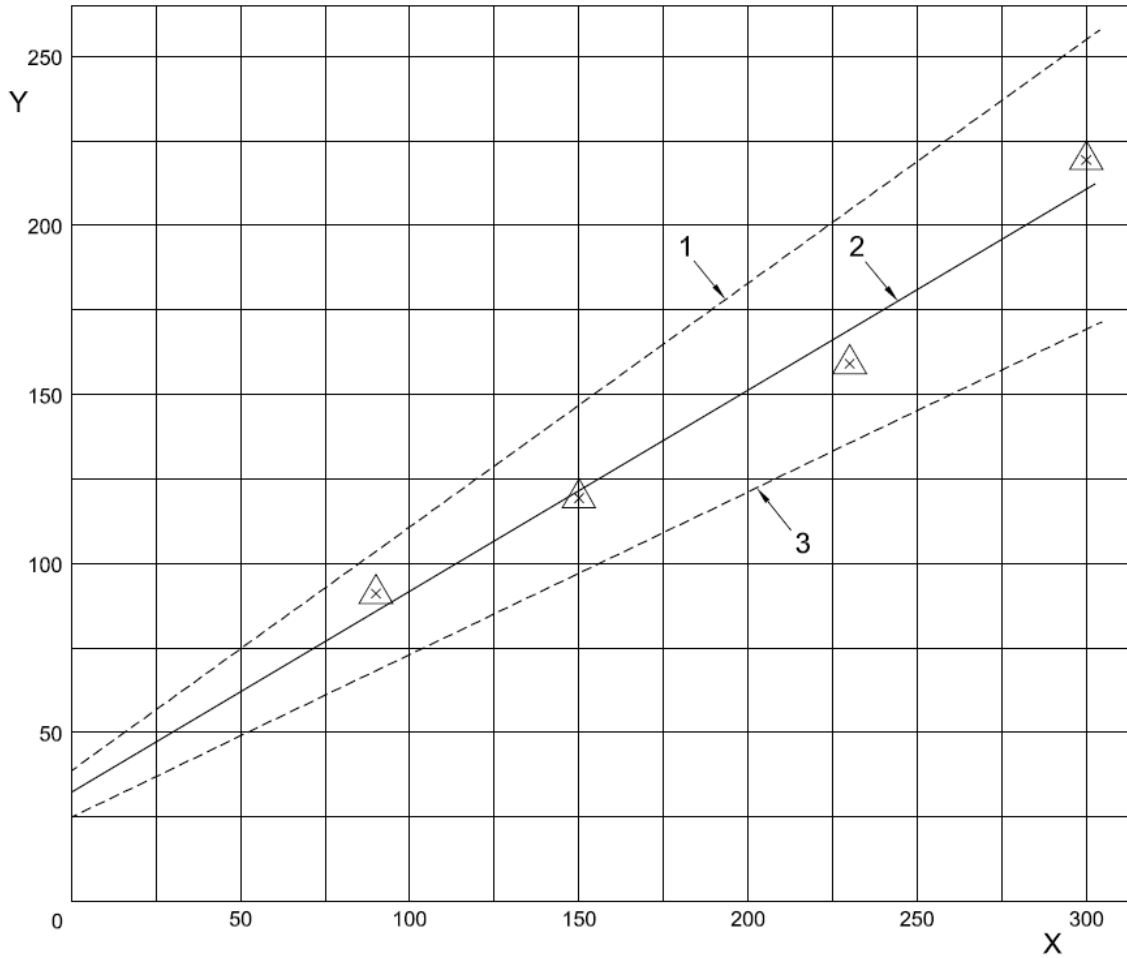

- Key**
- Y braking force, N
 - X input force, N
 - 1 +20 % limit
 - 2 line of best fit
 - 3 -20 % limit

Figure A.1 — Graph of lever force or pedal force (input force) against braking force, showing line of best fit and ±20 % limit lines

Annex B
(normative)

Brake performance – endurance test

B1 Brake performance — endurance test

B1.1 Requirement:

When tested by the method described in B.1.2, before the wear limit and no failure of any brake parts, the brakes shall achieve at least 60 % of the braking performance which was recorded at the highest operating force used during the performance tests TBIS 4210-4:2017, 4.6.5.7 c) items 1) and 2).

If the sample could not finish total 3,000 cycles brake, there should be a warning before the end of the wear limit (pad, rim and rotor).

B1.2 Test methods:

This test is made with a test speed of 12.5 km/h +/- 5%.

There by the 3,000 cycles (brake 3 sec. and release 3 sec. for 1 cycle) brake delay may not remain under a value of 2.2 m/s^2 +/- 10% whereby for the mass to be slowed down 100 kg.

An adjustment of the brakes is allowed.

A wind speed of a maximum of 12.5 km/h is allowed.

All rights reserved
Reprints must investigate

Bibliography

- [1] TBIS 4210-3:2016, *Cycles — Safety requirements for bicycles — Part 3: Common test methods*

All rights reserved
Reprints must investigate
