

Taiwan Bicycle Industry Standard

TBIS

4210-5

First edition

2016.01.01

**Cycles — Safety requirements for
bicycles —**

Part 5:

Steering test methods

Contents

Page

Foreword	iii
Introduction	v
1 Scope	1
2 Normative references	1
3 Terms and definitions	1
4 Test methods	1
4.1 Handlebar grips and plugs	1
4.2 Handlebar stem — Lateral bending test	2
4.3 Handlebar and stem assembly — Lateral bending test	3
4.4 Handlebar stem — Forward bending test	5
4.5 Handlebar to handlebar stem — Torsional security test	7
4.6 Handlebar stem to fork steerer — Torsional security test	8
4.7 Bar end to handlebar — Torsional security test	9
4.8 Aerodynamic extensions to handlebar — Torsional security test	9
4.9 Handlebar and stem assembly — Fatigue test	10

Foreword

Taiwan Bicycle Industry Standard (TBIS) is approved and announced by Taiwan Bicycle Association (TBA). The preparatory work of "Taiwan Bicycle Industry Standard" is carried out by the technical expert committee from TBIS. When TBA members are interested in the related standard that has been announced, and after they are approved by the R&D and patent committee of TBA, they will become the member of the technical expert committee of TBIS. TBA and Cycling & Health Tech Industry R&D Center (CHC) are in close cooperation to handle all matters applied and established by TBIS.

The structure, establishing process and revising of this standard should be proposed to and get determined by the R&D and Patent Committee of TBA. This standard is implemented after the announcement of TBA. Please be aware, some part of this document may involve patent rights. TBIS has no legal obligation to mark out where all or part of the patent is involved.

Background description:

After 2015, The International Organization for Standardization 4210: 2014 (ISO 4210:2014) will be the most commonly used safety standard in global bicycle industry. Although ISO 4210 is not a mandatory inspection standard in various economic markets, they are still requesting their bicycle products suppliers to follow the basis of ISO 4210 safety requirements. However, this phenomenon represents that they are unable to differentiate the quality and grade differences between bicycles and spare parts. In order to keep up the competitiveness of our bicycle industry in the international market, the technical expert committee of TBIS uses ISO 4210 as their investigation basis and propose a higher level of product safety and standard service, to establish TBIS especially for this purpose. To highlight on the quality, performance and reliability of those components that has passed TBIS inspection, which have already exceeded the international standard. In the meantime, TBIS is developing on the safety standard and testing technology on those bicycle parts that are excluded in ISO 4210, to ensure the product and identify the differences between product performance, which has become an important reference to drive the improvement on Taiwan bicycle industry Research & Design units.

Establishment History

- 1st: [TBIS General Meeting (rev. NP) Discussion] Total 13 companies and 18 industry experts participate, 2015.06.25.
- 2nd: [TBIS Working Draft (rev. WD) Discussion] Total 13 companies and 18 industry experts participate, 2015.06.25.
- 3rd: [TBIS Committee Draft (rev.CD) Discussion] Total 14 companies and 22 industry experts participate, 2015.07.21.
- 4th: [TBIS Enquiry stage (rev. DTS) Discussion] Total 15 companies and 19 industry experts participate, 2015.09.02.
- 5th: [TBIS Approval Stage (rev. FDTS) Discussion] Total 17 companies and 19 industry experts participate, 2015.10.28.
- 6th: [TBIS Subject Meeting] Total 17 companies and 19 industry experts participate, 2015.10.28.

Introduction

The purpose of this TBIS is to build the world's leading bicycle industry standards and norms bicycle manufacturing process to ensure product safety and external benefits effectively (including announcing internationally, producing high-valued products, and leading the R&D of bicycle industry, etc.), highlighting the product inspected by TBIS is in compliance with a higher safety requirement. While riding the bicycle on public roads, the laws and regulations of the country will be applicable.

TBIS 4210 consists of the following parts, under the general title *Cycles — Safety requirements for bicycles*:

- *Part 1: Terms and definitions*
- *Part 2: Requirements for city and trekking, young adult, mountain and racing bicycles*
- *Part 3: Common test methods*
- *Part 4: Braking test methods*
- *Part 5: Steering test methods*
- *Part 6: Frame and fork test methods*
- *Part 7: Wheels and rims test methods*
- *Part 8: Pedals and drive system test methods*
- *Part 9: Saddles and seat-post test methods*

Reference

The following documents, in whole or in part, are normatively referenced in this document and are indispensable for its application. For dated references, only the edition cited applies. For undated references, the latest edition of the referenced document (including any amendments) applies.

ISO 4210-1, *Cycles — Safety requirements for bicycles — Part 1: Terms and definitions*

ISO 4210-3:2014, *Cycles — Safety requirements for bicycles — Part 3: Common test methods*

ISO 4210-4:2014, *Cycles — Safety requirements for bicycles — Part 4: Braking test methods*

ISO 4210-5:2014, *Cycles — Safety requirements for bicycles — Part 5: Steering test methods*

ISO 4210-6:2014, *Cycles — Safety requirements for bicycles — Part 6: Frame and fork test methods*

ISO 4210-7:2014, *Cycles — Safety requirements for bicycles — Part 7: Wheel and rim test methods*

ISO 4210-8:2014, *Cycles — Safety requirements for bicycles — Part 8: Pedal and drive system test methods*

ISO 4210-9:2014, *Cycles — Safety requirements for bicycles — Part 9: Saddle and seat-post test methods*

ISO 5775-1, *Bicycle tyres and rims — Part 1: Tyre designations and dimensions*

ISO 5775-2, *Bicycle tyres and rims — Part 2: Rims*

Cycles — Safety requirements for bicycles —

Part 5: Steering test methods

1 Scope

This part of TBIS 4210 specifies the steering test methods for TBIS 4210-2.

2 Normative references

The following documents, in whole or in part, are normatively referenced in this document and are indispensable for its application. For dated references, only the edition cited applies. For undated references, the latest edition of the referenced document (including any amendments) applies.

TBIS 4210-1:2016, *Cycles – Safety requirements for bicycles – Part 1: Terms and definitions*

TBIS 4210-2:2016, *Cycles – Safety requirements for bicycles – Part 2: Requirements for city and trekking, young adult, mountain and racing bicycles*

TBIS 4210-3:2016, *Cycles – Safety requirements for bicycles – Part 3: Common test methods*

3 Terms and definitions

For the purposes of this document, the terms and definitions given in TBIS 4210-1 apply.

4 Test methods

4.1 Handlebar grips and plugs

4.1.1 Freezing test

Immerse the handlebar, with handlebar grips or plugs fitted, in water at room temperature for 1 h and then place the handlebar in a freezer until the handlebar is at a temperature lower than -5 °C . Remove the handlebar from the freezer and allow the temperature of the handlebar to reach -5 °C , and then apply a force of 70 N to the grip or plug in the loosening direction as shown in [Figure 1](#). Maintain the force until the temperature of the handlebar has reached $+5\text{ °C}$. It shall be permitted to create a hole in the plug to allow for the testing fixture to be fitted so long as the hole does not affect the seat of the plug in the handlebar and the fixture does not contact the handlebar during the test.

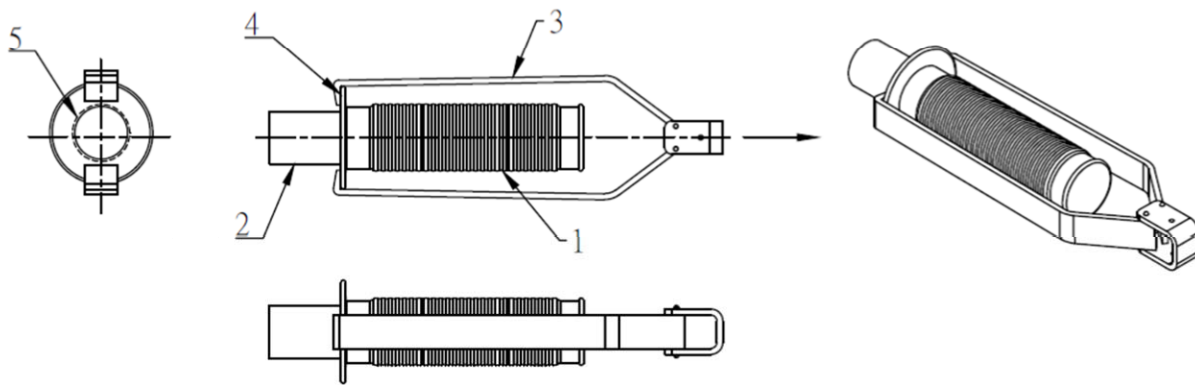

Key

- 1 handlebar grip
- 2 handlebar
- 3 drawing attachment
- 4 hooking ring
- 5 clearance

NOTE The hooking ring can be divided.

Figure 1 — Example of handlebar grip drawing attachment

4.1.2 Hot water test

Immerse the handlebar, with handlebar grips fitted, in hot water of $+60\text{ °C} \pm 2\text{ °C}$ for 1 h. Remove the handlebar from the hot water, allow the handlebar to stabilize at ambient temperature for 30 min, and apply a force of 100 N to the grip in the loosening direction as shown in [Figure 1](#). Maintain this force for 1 min.

4.2 Handlebar stem — Lateral bending test

For stems which have a quill for insertion into a fork steerer, clamp the quill securely in a fixture to the minimum insertion depth as specified in TBIS 4210-2:2016, 4.7.3, or for stem extensions which clamp directly on to an extended fork steerer, attach the extension to a fork steerer according to the manufacturer’s instructions and clamp this fork steerer securely in a fixture to the appropriate height. Assemble a test bar to the stem, and apply a force of F_1 at a distance of d from the axis of the stem as shown in [Table 1](#) and [Figure 2](#). Maintain this force for 1 min.

Table 1 — Forces and distances on handlebars

Bicycle type	City and trekking bicycles	Young adult bicycles	Mountain bicycles	Racing bicycles
Force, F_1 N	600	600	1 000	1 000
Distance, d mm	300	300	300	230

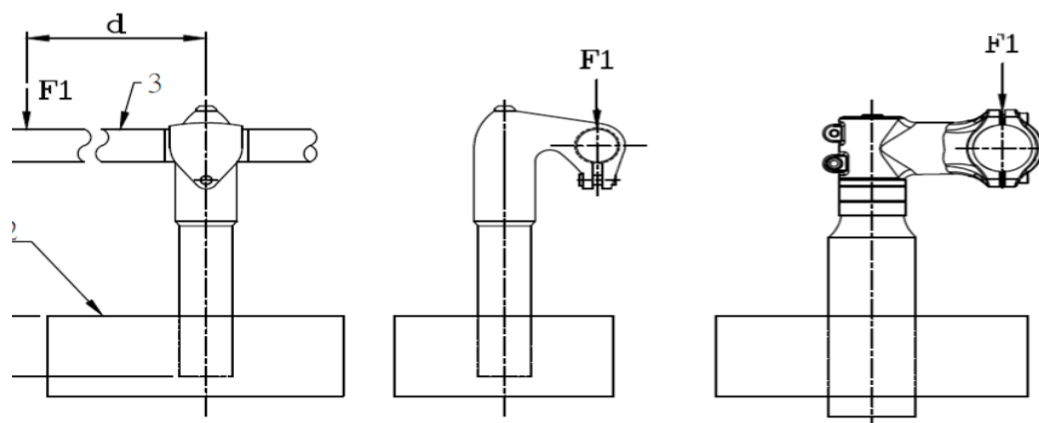

a) Combined stem and quill

b) Stem extension

Key

- 1 minimum insertion depth
- 2 clamping block
- 3 solid-steel bar

Figure 2 — Handlebar stem — Lateral bending test

4.3 Handlebar and stem assembly — Lateral bending test

Assemble the handlebar and stem in accordance with the manufacturer's instructions and, unless the handlebar and stem are permanently connected, e.g. by welding or brazing, align the grips portion of the handlebar in a plane perpendicular to the stem axis [see [Figure 3 a\)](#) or [Figure 4 a\)](#)]. For stems which have a quill for insertion into a fork steerer, clamp the quill securely in a fixture to the minimum insertion depth, or for stem extensions which clamp directly on to an extended fork steerer, attach the extension to a fork steerer according to the manufacturer's instructions and clamp this fork steerer securely in a fixture to the appropriate height. Apply a force of F_2 (see [Table 2](#)) at a distance of 50 mm from the free end of the handlebar and parallel to the axis of the fork steerer as shown in [Figures 3](#) or [4](#). Maintain this force for 1 min.

Table 2 — Forces on handlebars

Forces in newtons				
Bicycle type	City and trekking bicycles	Young adult bicycles	Mountain bicycles	Racing bicycles
Force, F_2	600	600	1 000	1 000

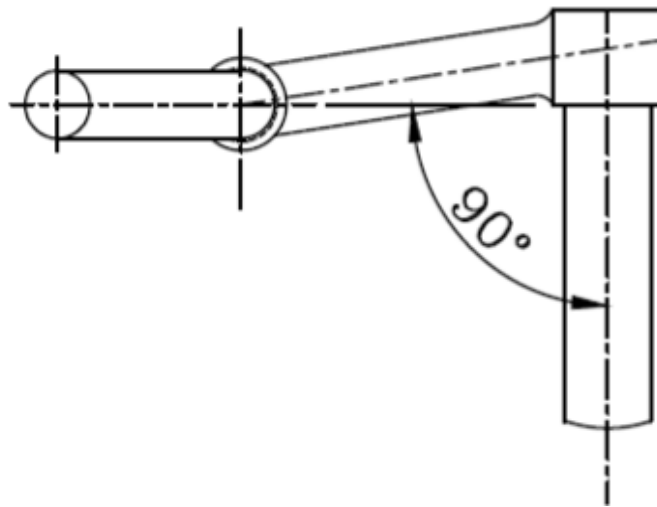

a) Orientation of adjustable handlebars

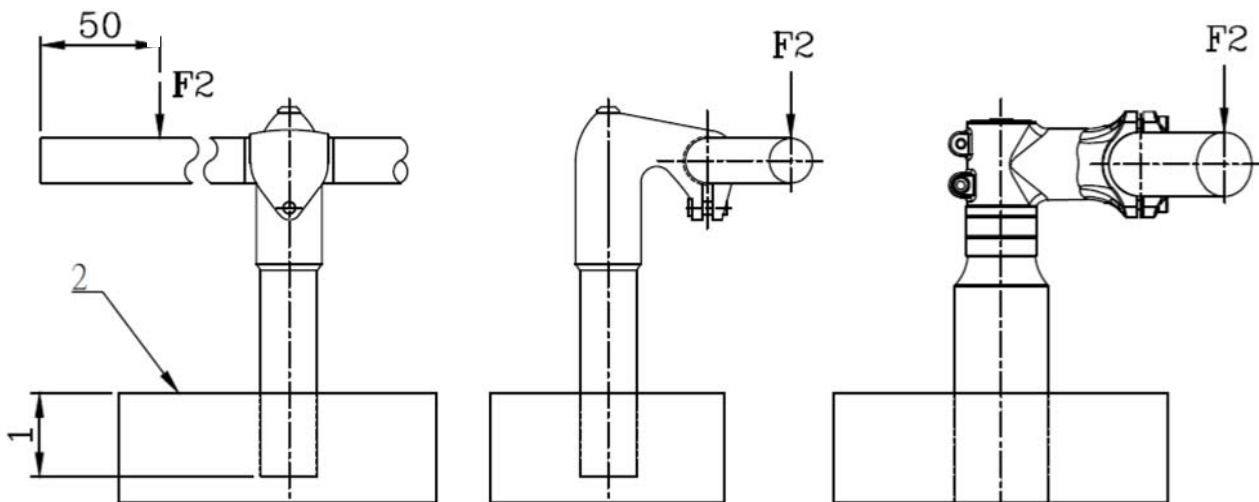

b) Combined stem and quill

c) Stem extension

Key

- 1 minimum insertion depth
- 2 clamping block

Figure 3 — Handlebar and stem assembly — Lateral bending test for city and trekking, young adult, and mountain bicycles

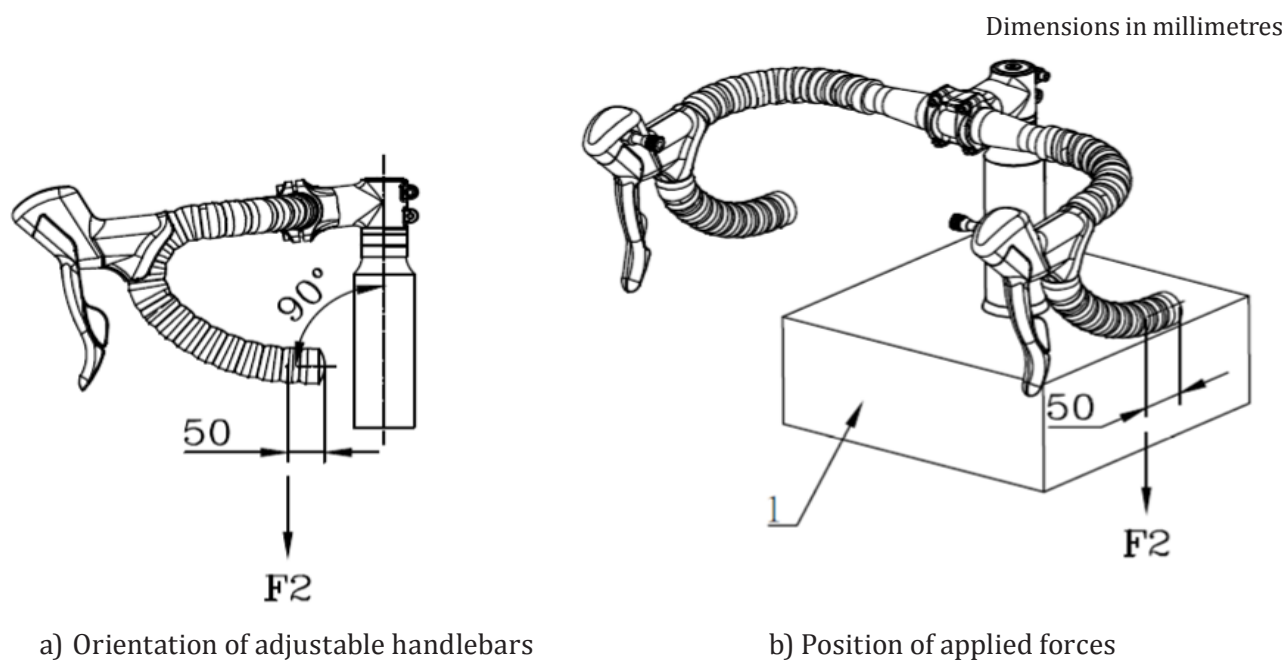

Key

1 clamping fixture

Figure 4 — Handlebar and stem assembly — Lateral bending test for racing bicycles

4.4 Handlebar stem — Forward bending test

4.4.1 Test method for stage 1

For stems which have a quill for insertion into a fork steerer, clamp the quill securely in a fixture to the minimum insertion depth, or for stem extensions which clamp directly on to an extended fork steerer, clamp the handlebar stem extension securely on to a suitable, solid-steel bar and clamp the bar in securely in a fixture, the projecting length of the bar not being critical.

Apply a force of F_3 through the handlebar attachment point in a forward and downward direction and at 45° to the axis of the quill or steel bar as shown in [Figure 5](#) and maintain this force for 1 min. The forces are given in [Table 3](#). Release the test force and measure any permanent deformation as specified in TBIS 4210-2:2016, 4.7.6.3.2.

If the handlebar stem meets the requirement of TBIS 4210-2:2016, 4.7.6.3.2, conduct stage 2 of the test.

Table 3 — Forces on stems

Bicycle type		Forces in newtons			
		City and trekking bicycles	Young adult bicycles	Mountain bicycles	Racing bicycles
Stage 1	Force, F_3	1 600	1 600	1 600	1 600
Stage 2	Force, F_4	2 000	2 000	2 600	2 300

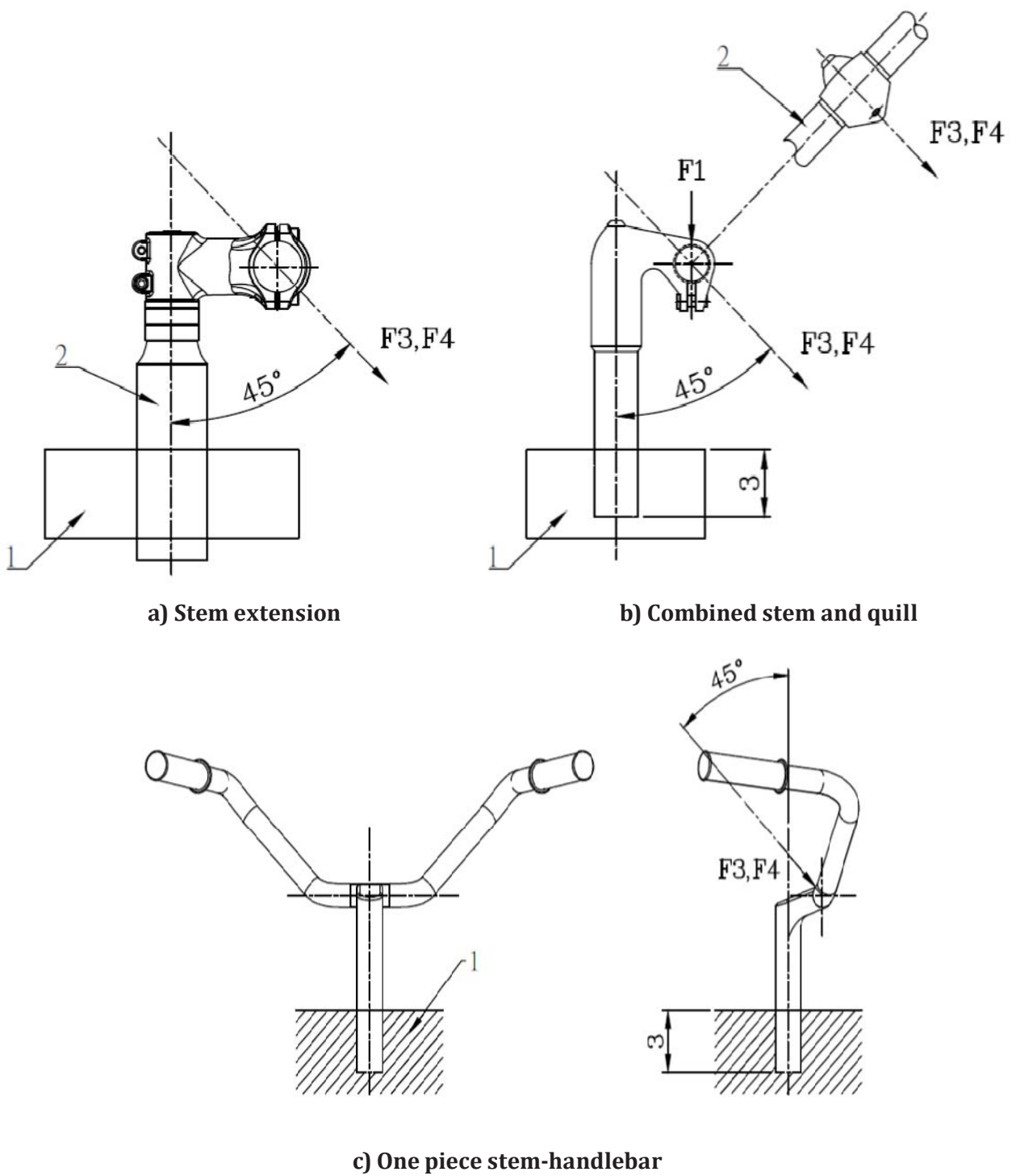

Key

- 1 clamping fixture
- 2 solid-steel bar
- 3 minimum insertion depth

Figure 5 — Handlebar stem — Forward bending test

4.4.2 Test method for stage 2

With the handlebar stem mounted as in stage 1 (see 4.4.1), apply a progressively increasing force in the same position and direction as in 4.4.1 until either the force reaches a maximum of F_4 or until the handlebar stem deflects 50 mm measured at the point of application of the test force and in the direction of the test force. If the stem does not yield or continue to yield, maintain the force for 1 min. The forces are given in Table 3.

4.5 Handlebar to handlebar stem — Torsional security test

Assemble the handlebar correctly in the handlebar stem with the locking system tightened in accordance with the manufacturer's instructions and clamp the handlebar stem securely in a fixture to the minimum insertion depth and with its axis vertical. Apply a torque of T_1 about the centreline of the stem-clamp. Divide the torque equally by vertically, downward forces applied to both sides of the handlebar and maintain the forces for 1 min. The torque is given in Table 4.

NOTE The exact method of applying the torque will vary with the type of handlebar, and an example is shown in Figure 6 ($T_1 = F \times L$).

Table 4 — Torque on handlebar

Torques in newton metres				
Bicycle type	City and trekking bicycles	Young adult bicycles	Mountain bicycles	Racing bicycles
Torque, T_1	60	60	80	60

Dimensions in millimetres

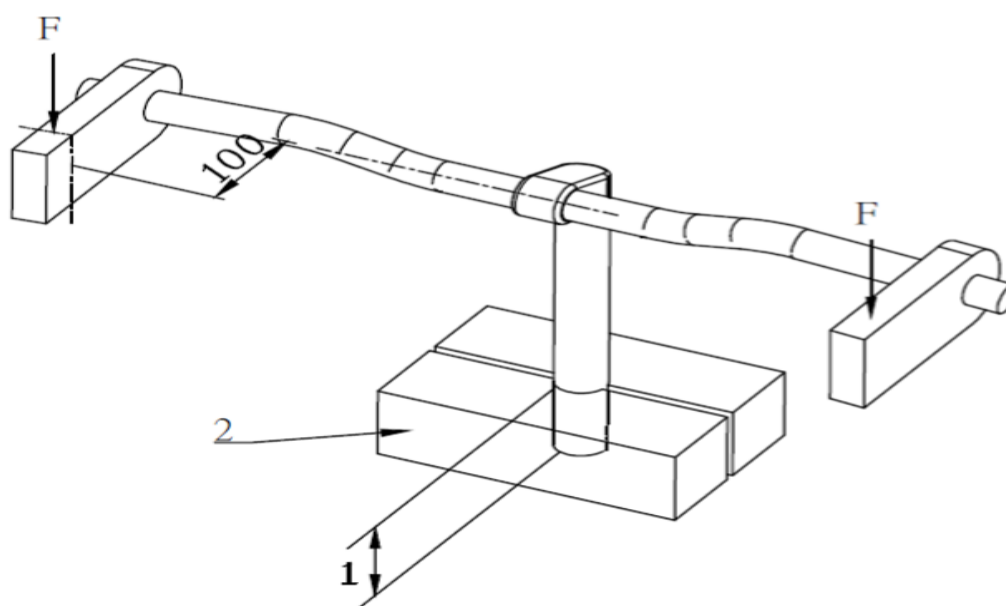

Key

- 1 minimum insertion depth
- 2 clamping block

Figure 6 — Handlebar to handlebar stem — Torsional security test for applying forces to clamping block

4.6 Handlebar stem to fork steerer — Torsional security test

Assemble the fork steerer correctly in the frame and attach the handlebar stem to the fork steerer with the locking system tightened in accordance with the manufacturer’s instructions, and apply a torque of T_2 once in each direction of possible rotation by applying a force on the test bar in a plane perpendicular to the axis of the fork steerer/handlebar stem. Maintain each torque for 1 min. The torque is given in [Table 5](#). The exact method of applying the torque can vary, and an example is shown in [Figure 7](#).

Table 5 — Torque on handlebar stem

Torques in newton metres				
Bicycle type	City and trekking bicycles	Young adult bicycles	Mountain bicycles	Racing bicycles
Torque, T_2	40	40	50	40

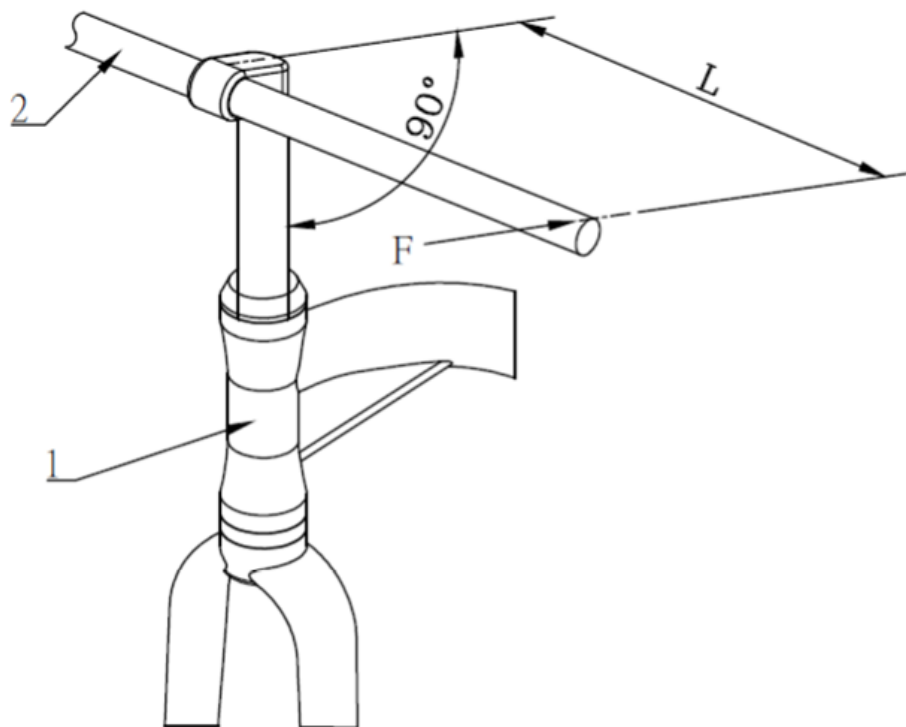

- Key**
- 1 frame and fork assembly
 - 2 solid-steel bar

Figure 7 — Handlebar stem to fork steerer — Torsional security test

4.7 Bar end to handlebar — Torsional security test

Secure the handlebar in a suitable fixture and assemble the bar end on the handlebar tightening the fixings in accordance with the bar end manufacturer’s instructions. Apply a force of F_5 (see [Table 6](#)) to the following position:

- a) if the bar end’s length is more than 100 mm, at a distance of 50 mm from the free end of the bar end [see [Figure 8 a](#)];
- b) if the bar end’s length is from 50 mm to 100 mm, at a distance of 50 mm from the axis of the handlebar [see [Figure 8 b](#)];
- c) if the bar end’s length is less than 50 mm, apply a load to the mid-point of the bar end [see [Figure 8 c](#)].

Maintain this force for 1 min.

Table 6 — Forces on bar end

Forces in newtons				
Bicycle type	City and trekking bicycles	Young adult bicycles	Mountain bicycles	Racing bicycles
Force, F_5	300	300	500	300

Dimensions in millimetres

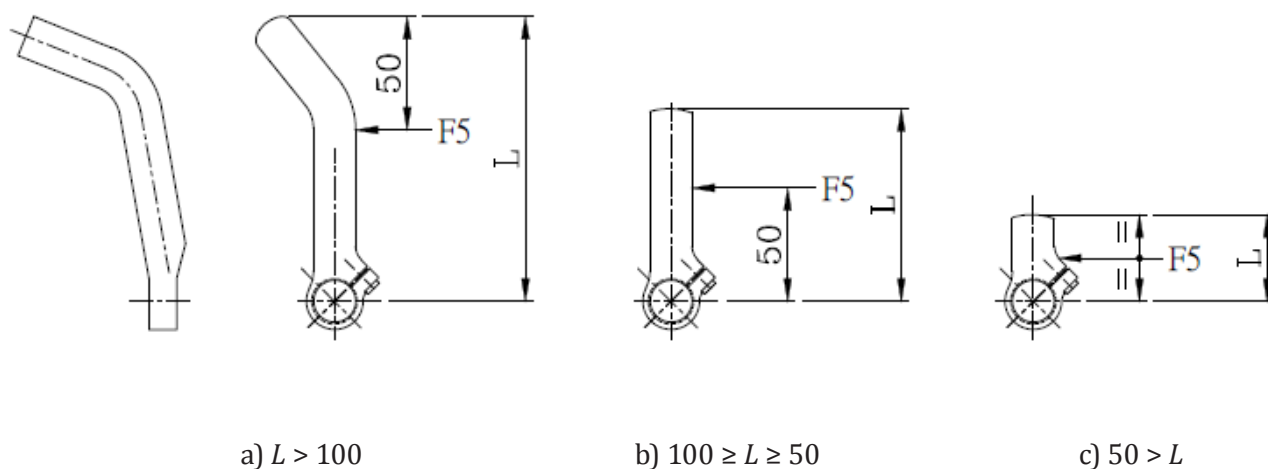

Key

L bar end’s length

Figure 8 — Bar end to handlebar — Torsional security test

4.8 Aerodynamic extensions to handlebar — Torsional security test

Secure the handlebar in the stem intended for use and assemble the extension on the handlebar tightening all the fixings in accordance with the extension, handlebar, and handlebar stem manufacturer’s instructions. The steering axis should be vertical. Apply a vertical force of 300 N to the extension on the position giving the maximum torque to the clamps as shown in [Figures 9 a](#)) and b). The exact method of applying the force can vary with the type of aerodynamic extension, and an example is shown in [Figure 9](#).

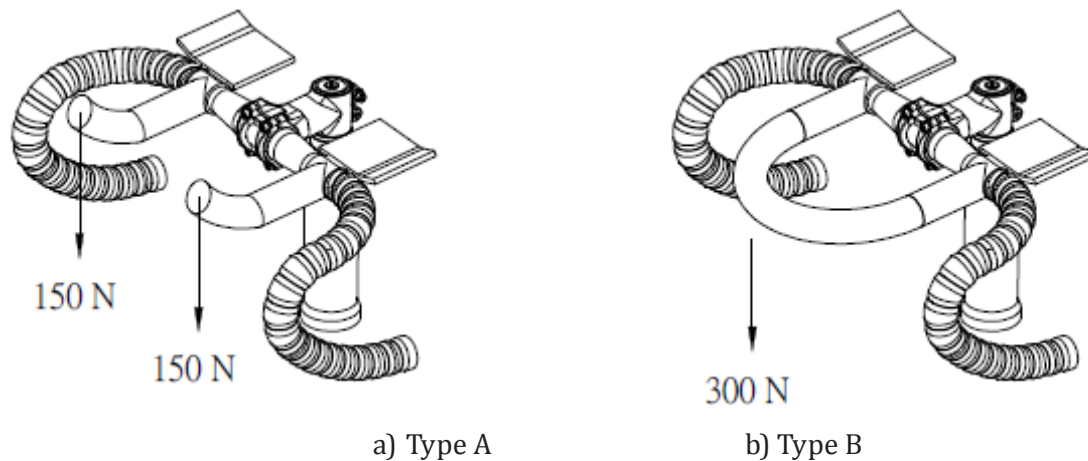

Figure 9 — Aerodynamic extension to handlebar — Torsional security test

4.9 Handlebar and stem assembly — Fatigue test

4.9.1 Test method for city and trekking, young adult, and mountain bicycles

4.9.1.1 Test method for stage 1 (out-of-phase)

Unless the handlebar and stem are permanently connected, e.g. by welding or brazing, align the grips of portion of the handlebar in a plane perpendicular to the stem axis [see [Figure 3 a\)](#)] and secure the handlebar to the stem according to the manufacturer's instructions.

Clamp the handlebar stem securely in a fixture to the minimum insertion depth as specified in TBIS 4210-2:2016, 4.7.3, or in the case of a stem extension which is intended to be clamped to an extended fork steerer, secure the extension using the manufacturer's recommended tightening procedure to an extended fork steerer which is secured in fixture to the appropriate length.

For handlebars where the manufacturer states that they are not intended for use with bar ends, apply fully reversed forces of stage 1 out-of-phase F_6 at a position 50 mm from the free end for each side of the handlebar for 120 000 cycles, with the forces at each end of the handlebar being out of phase with each other and parallel to the axis of the fork steerer as shown in [Figure 10 a\)](#). The forces are given in [Table 7](#). The maximum test frequency shall be maintained as specified in TBIS 4210-3:2016, 4.5.

Where a bicycle manufacturer fits bar ends, fit the bar ends to the handlebar according to the manufacturer's tightening instructions but with the bar ends located in a plane perpendicular to the handlebar stem axis and apply the out-of-phase forces to the bar ends, as shown in [Figure 8](#) and [Figure 11 a\)](#).

Where a handlebar manufacturer specifies that his handlebars are suitable for use with bar ends, conduct the test with the out-of-phase forces applied to simulated bar ends, as shown in [Figure 11 b\)](#).

If the handlebar meets the requirement as specified in TBIS 4210-2:2016, 4.7.7.2, remove any bar ends and conduct stage 2 in phase F_7 of the test with the assembly in the same mountings.

Table 7 — Forces on handlebars and bar ends

Bicycle type		City and trekking bicycles	Young adult bicycles	Mountain bicycles	Racing bicycles
Stage 1	Out-of-phase, F_6	200	200	270	280
Stage 2	In phase, F_7	250	250	450	400
Stage 3	Out-of-phase, F_6	250	250	320	330
Stage 4	In phase, F_7	300	300	500	450

Forces in newtons

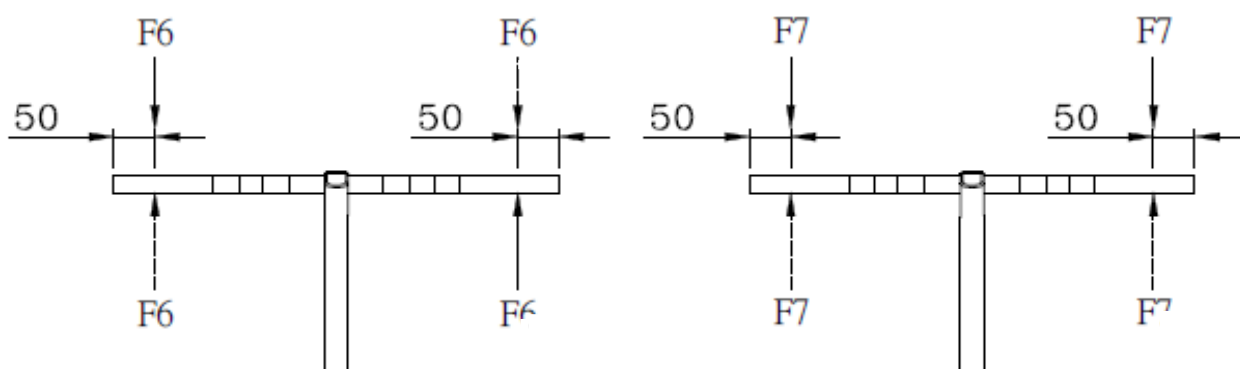

a) Stage 1 and stage 3 — Out-of-phase loading

b) Stage 2 and stage 4 — In-phase loading

Figure 10 — Handlebar and stem — Fatigue tests for city and trekking, young adult, and mountain bicycles

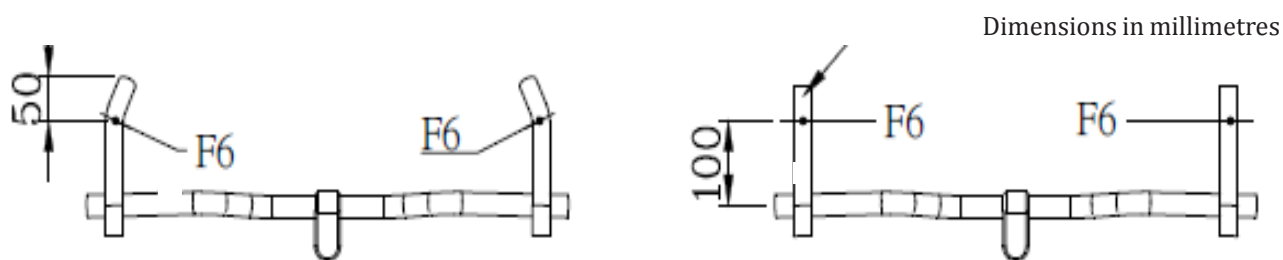

a) Test for handlebar fitted with bar ends (plan view)

b) Test for handlebar intended for bar ends (plan view)

Figure 11 — Handlebar incorporating bar ends — Out of phase fatigue tests for city and trekking, young adult, and mountain bicycles

4.9.1.2 Test method for stage 2 (in phase)

Apply fully reversed forces of stage 2 in phase F_7 at a position 50 mm from the free end for each side of the handlebar for 120 000 cycles, with the forces at each end of the handlebar being in phase with each other and parallel to the axis of the handlebar stem, as shown in Figure 10 b). The maximum test frequency shall be maintained as specified in TBIS 4210-3:2016, 4.5.

TBIS 4210-5:2016

If the handlebar meets the requirement as specified in TBIS 4210-2:2016, 4.7.7.2, and conduct stage 3 out-of-phase of the test with the assembly in the same mountings.

4.9.1.3 Test method for stage 3 (out-of-phase)

Apply fully reversed forces of stage 3 out-of-phase F_6 at a position 50 mm from the free end for each side of the handlebar for 100 000 cycles, with the forces at each end of the handlebar being out of phase with each other and parallel to the axis of the handlebar stem, as shown in [Figure 10 a](#)). The maximum test frequency shall be maintained as specified in TBIS 4210-3:2016, 4.5.

If the handlebar meets the requirement as specified in TBIS 4210-2:2016, 4.7.7.2, and conduct stage 4 of the test with the assembly in the same mountings.

4.9.1.4 Test method for stage 4 (in phase)

Apply fully reversed forces of stage 4 in phase F_7 at a position 50 mm from the free end for each side of the handlebar for 100 000 cycles, with the forces at each end of the handlebar being in phase with each other and parallel to the axis of the handlebar stem, as shown in [Figure 10 b](#)). The maximum test frequency shall be maintained as specified in TBIS 4210-3:2016, 4.5.

4.9.2 Test method for racing bicycles

4.9.2.1 Test method for stage 1 (out-of-phase)

Unless the handlebar and stem are permanently connected, e.g. by welding or brazing, align the hand grips or the equivalent parts of the handlebar in a plane perpendicular to the steering axis (see [Figure 12](#)), and secure the handlebar to the stem according to the manufacturer's instructions.

Clamp the handlebar stem securely in a fixture to the minimum insertion depth as specified in TBIS 4210-2:2016, 4.7.3, or in the case of a stem extension which is intended to be clamped to an extended fork steerer, secure the stem-extension using the manufacturer's recommended tightening procedure, to an extended fork steerer which is secured in the fixture with the appropriate length projecting.

Attach to the handlebar two suitable devices that reproduce the brake-lever fixtures without either reducing or increasing the local handlebar strength. Each device shall incorporate a pin for connection to a ball joint with its axes located 15 mm from the outer surface of the handlebar, or such greater distance which accurately reproduces the position of the appropriate brake lever pivot (see [Figure 12](#)).

Through the ball joints, apply reversed forces of stage 1 out-of-phase F_6 to the pin of the device on each side of the handlebar for 120 000 cycles, with the forces at each side of the handlebar being out of phase with each other and parallel to the axis of the fork steerer as shown in [Figure 13 a](#)). The forces are given in [Table 7](#). The maximum test frequency shall be maintained as specified in TBIS 4210-3:2016, 4.5.

If the assembly meets the requirement as specified in TBIS 4210-2:2016, 4.7.7.2, conduct stage 2 (in phase) of the test on the same assembly, in the same mountings.

4.9.2.2 Test method for stage 2 (in phase)

Through the ball joints, apply reversed forces of stage 2 in phase F_7 to the pin of the device on each side of the handlebar for 120 000 cycles, with the forces at each side of the handlebar being in phase with each other and parallel to the axis of the handlebar stem of the fork steerer, as shown in [Figure 13 b](#)). The forces are given in [Table 7](#). The maximum test frequency shall be maintained as specified in TBIS 4210-3:2016, 4.5.

If the assembly meets the requirement as specified in TBIS 4210-2:2016, 4.7.7.2, conduct stage 3 (out-of-phase) of the test on the same assembly, in the same mountings.

4.9.2.3 Test method for stage 3 (out-of-phase)

Through the ball joints, apply reversed forces of stage 3 out-of-phase F_6 to the pin of the device on each side of the handlebar for 100 000 cycles, with the forces at each side of the handlebar being out of phase with each other and parallel to the axis of the handlebar stem of the fork steerer, as shown in [Figure 13 a](#)). The forces are given in [Table 7](#). The maximum test frequency shall be maintained as specified in TBIS 4210-3:2016, 4.5.

If the assembly meets the requirement as specified in TBIS 4210-2:2016, 4.7.7.2, conduct stage 4 (in phase) of the test on the same assembly, in the same mountings.

4.9.2.4 Test method for stage 4 (in phase)

Through the ball joints, apply reversed forces of stage 4 in phase F_7 to the pin of the device on each side of the handlebar for 100 000 cycles, with the forces at each side of the handlebar being in phase with each other and parallel to the axis of the handlebar stem of the fork steerer, as shown in [Figure 13 b](#)). The forces are given in [Table 7](#). The maximum test frequency shall be maintained as specified in TBIS 4210-3:2016, 4.5.

Dimensions in millimetres

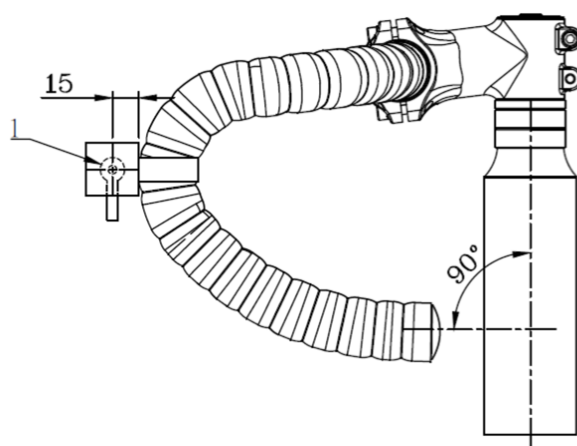

Key

1 ball joint

Figure 12 — Device reproducing the brake fixture for racing bicycles

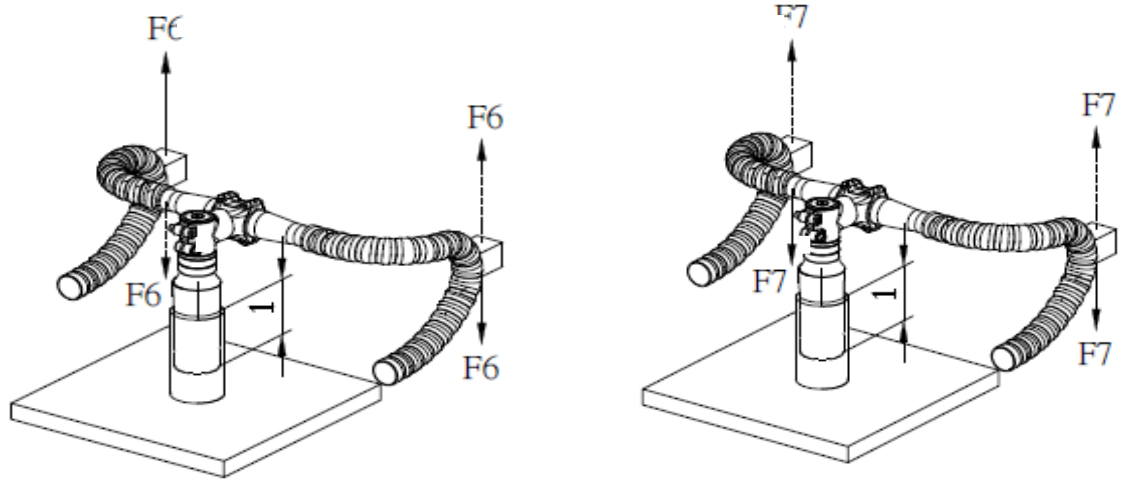

a) Stage 1 — Out-of-phase loading

b) Stage 2 — In-phase loading

Key

1 minimum insertion depth

Figure 13 — Handlebar and stem assembly — Fatigue test for racing bicycles

