

Taiwan Bicycle Industry Standard

TBIS

15194

Third edition

Electrically power assisted cycles standard

All rights reserved
Reprints must investigate

Contents

	Page
Foreword	vii
Background description	viii
1. SCOPE	01
2. Normative references	02
3. Terms and definitions	03
4. SAFETY REQUIREMENTS AND/OR PROTECTIVE MEASURES 11	
4.1 General	11
4.2 Electrical requirements	11
4.2.1 Electric circuit	11
4.2.2 Controls and symbols	11
4.2.3 Batteries	11
4.2.4 Battery charger	12
4.2.5 Electric cables and connections	13
4.2.6 Wiring	13
4.2.7 Power cables and conduits	14
4.2.8 External and internal electrical connections	14
4.2.9 Moisture resistance	15
4.2.10 Mechanical strength test	15
4.2.11 Maximum speed for which the electric motor gives assistance	15
4.2.12 Start-up assistance mode	16
4.2.13 Power management	17
4.2.14 Maximum power measurement	19
4.2.15 Electro Magnetic Compatibility	20
4.2.16 Failure mode	20
4.2.17 Anti-tampering measure	20

4.3 Mechanical requirements	22
4.3.1 General	22
4.3.2 Sharp edges	23
4.3.3 Security and strength of safety-related fasteners	23
4.3.4 Protrusions	24
4.3.5 Brakes	24
4.3.6 Steering	40
4.3.7 Frames	52
4.3.8 Front fork	64
4.3.9 Wheels and wheel/tyre assembly	75
4.3.10 Rims, tyres and tubes	81
4.3.11 Front mudguard	84
4.3.12 Pedals and pedal/crank drive system	86
4.3.13 Drive-chain and drive belt	97
4.3.14 Chain-wheel and belt-drive protective device	98
4.3.15 Saddles and seat-posts	102
4.3.16 Spoke protector	110
4.3.17 Luggage carriers	110
4.3.18 Road-test of a fully-assembled EPAC	110
4.3.19 Lighting systems and reflectors	110
4.3.20 Warning device	112
4.3.21 Thermal hazards	112
4.3.22 Performance Levels (PLrs) for control system of EPACs	112
4.4 List of significant hazards	112
5 Marking, labelling	113
5.1 Requirement	113
5.2 Marking test	114
5.2.1 Marking Durability test	114
5.2.2 Marking Safety requirement	115
6 Instruction for use	115

Annex A (informative) Example of recommendation for battery charging..... 119

Annex B (informative) Example of relation between speed/torque/current..... 120

Annex C (normative) Electromagnetic compatibility of EPAC and ESA 123

C.1 Conditions applying to EPAC and to electrical/electronic sub-assemblies(ESA) 123

C.1.1 Marking 123

C.1.2 Requirements 123

C.2 Method of measuring broad-band electromagnetic radiation from EPAC 127

C.2.1 Measuring equipment..... 127

C.2.2 Test method 127

C.2.3 Measurement 128

C.3 Method of measuring narrow band electromagnetic radiation from EPAC 128

C.3.1 General 128

C.3.2 Antenna type, position and orientation. 128

C.4 Methods of testing EPAC immunity to electromagnetic radiation..... 128

C.4.1 General 128

C.4.2 Expression of results 128

C.4.3 Test conditions..... 128

C.4.4 State of the EPAC during the tests 129

C.4.5 Type, position and orientation of the field generator 129

C.4.6 Requisite test and condition 131

C.4.7 Generation of the requisite field strength..... 131

C.4.8 Inspection and monitoring equipment..... 133

C.5 Method of measuring broad-band electromagnetic radiation from separate technical units (ESA) 133

C.5.1 General 133

C.5.2 State of the ESA during the test 133

C.5.3 Antenna type, position and orientation..... 133

C.6 Method of measuring narrow-band electromagnetic radiation from separate technical units (ESAs)..... 133

C.6.1 General 133

C.6.2 Test conditions 134

C.6.3 State of the ESA during the tests..... 134

C.6.4 Antenna type, position and orientation..... 134

C.7 Methods of testing the ESA immunity to electromagnetic radiation 134

C.7.1 General 134

C.7.2 Expression of results 134

C.7.3 Test conditions..... 134

C.7.4 State of the ESA during the tests..... 134

C.7.5 Requisite test and condition 134

C.7.6 Generation of the requisite field strength..... 135

C.7.7 Inspection and monitoring equipment..... 136

C.8 ESD test..... 136

Annex D (informative) Steering geometry 137

Annex E (informative) Dummy fork characteristics 138

Annex F (informative) Explanation of the method of least squares for obtaining line of best fit and $\pm 20\%$ limit lines for braking performance linearity..... 140

Annex G (informative) Fork mounting fixture 143

Annex H (informative) Wheel/tyre assembly -Fatigue test 144

Annex I (informative) Light, warning device, on/off symbols..... 146

Annex J (informative) Walk assist mode symbols..... 147

Annex K (informative) Dynamic strength test on fully assembled bicycle... 148

Annex L (informative) Electrically power assisted bicycles- Test method of travelling distance 150

Annex M (informative) Assistant force test for electrically power assisted bicycles .. 154

Annex N (informative) Climate test for electrically power assisted bicycles..... 160

Foreword

Taiwan Bicycle Industrial Standard (TBIS) is approved and announced by Taiwan Bicycle Association (TBA). The preparatory work of "Taiwan Bicycle Industrial Standard" is carried out by the technical expert committee from TBA. When TBA members are interested in related standard that has been announced, and after they are approved by R&D and patent committee of TBA, they will become the member of the technical expert committee of TBIS. TBA and Cycling & Health Tech Industry R & D Center (CHC) are close cooperation to handle all matters applied and established by TBIS.

The structure, establishing process and revising of this standard shall be proposed to and get determined by the R&D and patent committee of TBA, This standard is implemented after the announcement of TBA. Please be aware, some part of this document may involve patent rights. TBIS has no legal obligation to mark out where all or part of the patent is involved.

Background description:

EN 15194 the standard of Cycles-Electrically power assisted cycles- EPAC Bicycles, which announcement in 2017, and it will instead of EN15194:2009 +A1:2011 to be the most complete standard of electrically power assisted cycles. Although EN 15194 is not a mandatory inspection standard in various economic markets, they are still requesting their bicycle products suppliers to follow the basis of EN 15194 safety requirements.

However, this phenomenon represents that they are unable to differentiate the quality and grade differences between EPAC bicycles and spare parts. In order to keep up the competitiveness of our bicycle industry in the international market, the technical expert committee of TBIS uses EN 15194 as their investigation basis and propose a higher level of product safety and standard service, to establish TBIS especially for this purpose. To highlight on the quality, performance and reliability of those components that has passed TBIS inspection, which have already exceeded the international standard. In the meantime, TBIS is developing on the safety standard and testing technology on those bicycle parts that are excluded in EN 15194, to ensure the product and identify the differences between product performance, which has become an important reference to drive the improvement on Taiwan bicycle industry Research & Design units.

Establishment history:

- 1st: [TBIS General meeting (rev. NP) Discussion] ∙ [TBIS Working Draft(rev. WD Discussion)] Total 20 companies 與 21 industry expert participate, 2016.04.22.
- 2nd: [TBIS Committee Draft(rev. CD) Discussion] ∙ [TBIS Enquiry Stage(rev. DTS) Discussion] Total 18 companies and 18 industry expert participate, 2016.06.24.
- 3rd: [TBIS Approval Stage(rev. FDTS) Discussion] Total 14 companies and 22 industry expert participate,2016.11.04.
- 4th: [TBIS Committee Draft(rev. CD) Discussion] ∙ [TBIS Enquiry stage (rev. DTS) Discussion] Total 16 companies and 16 industry experts participate, 2017.04.20.
- 5th: [TBIS Approval Stage (rev. FDTS) Discussion] Total 13 companies and 13 industry experts participate, 2017.07.28.
- 6th: [TBIS Amendment (rev. FDTS) Discussion] Total 14 companies and 15 industry experts participate, 2018.04.25.
- 6th: [TBIS Amendment (rev. FDTS) Discussion] Total 14 companies and 14 industry experts participate, 2018.09.19.

Taiwan electrically power assisted cycle industry standard

1. Scope

This industry standard applies to EPAC bicycles for private and commercial use with exception of EPAC intended for hire from unattended station.

This industry standard is intended to cover all common significant hazards, hazardous situations and events (see Clause 4) of electrically power assisted bicycles, when used as intended and under condition of misuse that are reasonably foreseeable by the manufacturer.

This industry standard is intended to cover electrically power assisted bicycles of a type which have a maximum continuous rated power of 0,25 kW, of which the output is progressively reduced and finally cut off as the EPAC reaches a speed of 25 km/h, or sooner, if the cyclist stops pedalling.

This industry standard specifies requirements and test methods for engine power management systems, electrical circuits including the charging system for the design and assembly of electrically power assisted bicycles and sub-assemblies for systems having a rated voltage up to and including 48 V d.c. or integrated battery charger with a nominal 230 V a.c. input.

This industry standard specifies safety and safety related performance requirements for the design, assembly, and testing of EPAC bicycles and subassemblies intended for use on public roads, and lays down guidelines for instructions on the use and care of such bicycles.

This industry standard applies to EPAC bicycles that have a maximum saddle height of 635 mm or more and that are intended for use on public roads.

Maximum saddle height

Bicycle type	City and trekking bicycles	Young adult bicycles	Mountain bicycles	Racing bicycles
maximum saddle height	635 mm or more	635 or more and less than 750	635 mm or more	635 mm or more

2. Normative references

The following documents, in whole or in part, are normatively referenced in this document and are indispensable for its application. For dated references, only the edition cited applies. For undated references, the latest edition of the referenced document (including any amendments) applies.

ISO 4210-1:2014, Cycles — Safety requirements for bicycles — Part 1: Terms and definitions.

ISO 4210-2:2015, Cycles — Safety requirements for bicycles — Part 2: Requirements for city and trekking, young adult, mountain, racing bicycles.

ISO 4210-3:2014, Cycles — Safety requirements for bicycles — Part 3: Common test methods.

ISO 4210-4:2014, Cycles — Safety requirements for bicycles — Part 4: Braking test methods.

ISO 4210-5:2014, Cycles — Safety requirements for bicycles — Part 5: Steering test methods.

ISO 4210-6:2015, Cycles — Safety requirements for bicycles — Part 6: Frame and fork test methods.

ISO 4210-7:2014, Cycles — Safety requirements for bicycles — Part 7: Wheel and rim test methods.

ISO 4210-8:2014, Cycles — Safety requirements for bicycles — Part 8: Pedal and drive system test methods.

ISO 4210-9:2014, Cycles — Safety requirements for bicycles — Part 9: Saddle and seat-post test methods.

prEN 15194:2015, Cycles — Electrically power assisted cycles - EPAC Bicycles

TBIS 4210:2016, —Taiwan Bicycle Industry Standard

EN 15194:2017, Cycles — Electrically power assisted cycles - EPAC Bicycles

3. Terms and definitions

The terms and the definitions given in TBIS 15194:2017 apply.

3.1 cycle

vehicle that has at least two wheels and is propelled solely or mainly by the muscular energy of the person on that vehicle, in particular by means of pedals.

3.2 bicycle

two-wheeled vehicle that is propelled solely or mainly by the muscular energy of the person on that vehicle, in particular by means of pedals.

3.3 electrically power assisted cycle (EPAC)

cycle, equipped with pedals and an auxiliary electric motor, which cannot be propelled exclusively by means of this auxiliary electric motor, except in the start-up assistance mode.

3.4 city and trekking bicycle

bicycle designed for use on public roads primarily for means of transportation or leisure.

3.5 mountain-bicycle

bicycle designed for use off-road on rough terrain, on public roads and on public pathways equipped with a suitably strengthened frame and other components, and, typically, with wide-section tyres with coarse tread patterns and a wide range of transmission gears.

3.6 racing-bicycle

bicycle intended for high-speed amateur use on public roads having a steering assembly with multiple grip positions allowing for an aerodynamic posture, a multi-speed transmission system, tyre width not greater than 28 mm, and a maximum mass of 12 kg for the fully assembled bicycle.

3.7 recumbent bicycle

bicycle that places the rider in a laid-back reclining position.

3.8 young adult bicycle

bicycle designed for use on public roads by a young adult whose weight is less than 40 kg with maximum saddle height of 635 mm or more and less than 750 mm.

3.9 fully assembled bicycle

bicycle fitted with all the components necessary for its intended use.

3.10 folding bicycle

bicycle designed to fold into a compact form, facilitating transport and storage.

3.11 bar-end

extension secured to the end of a handlebar to provide an additional hand-grip and usually with its axis perpendicular to the axis of the end of the handlebar.

3.12 brake-lever

lever that operates a braking device.

3.13 disc-brake

brake in which pads are used to grip the lateral faces of a thin disc attached to or incorporated in the wheel-hub.

3.14 braking distance

distance travelled by a bicycle between the commencement of braking (3.18) and the point at which the bicycle comes to rest.

3.15 braking force F_{Br}

tangential rearward force between the tyre and the ground or the tyre and the drum or belt of the test machine.

3.16 commencement of braking

point on the test track or test machine at which the brake actuating device operated directly by the riders hand or foot or by a test mechanism starts to move from its rest position.

3.17 brake-lever cut-off switch

device that cuts off the motor assistance while using the brake lever.

3.18 composite materials

component that is entirely or partially made of a non-metallic matrix materials which is reinforced by metallic or non-metallic materials such as short or long fibres, fabric or particles.

3.19 composite wheels

wheel assembly containing any composite material.

3.20 continuous rated power

output power specified by manufacturer, at which the motor reaches its thermal equilibrium at given ambient conditions.

3.21 thermal equilibrium

temperatures of motor parts which do not vary more than 2K per hour.

3.22 crank assembly

assembly for fatigue testing consisting of the drive side and the non-drive side crank arm, the pedal spindle-adaptors, the bottom-bracket spindle, and the first component of the drive system.

3.23 cut off speed

speed reached, by the EPAC, at the moment the current has dropped to zero or to the no load current value.

3.24 drive belt

seamless ring belt which is used as a means of transmitting motive force.

3.25 dummy fork

test fork manufactured to specific characteristics that can be substituted within a test for either the fork supplied by the manufacturer or where a fork has not been supplied.

3.26 electromagnetic compatibility

ability of an EPAC or one of its electrical/electronic systems to function satisfactorily in its electromagnetic environment without introducing intolerable electromagnetic disturbance to anything in that environment.

3.27 electromagnetic disturbance

electromagnetic phenomenon such as electromagnetic noise, an unwanted signal or a change in the propagation medium itself which may degrade the performance of an EPAC or one of its electronic/electrical systems.

3.28 electromagnetic environment

all electromagnetic phenomena present in a given situation.

3.29 electromagnetic immunity

ability of an EPAC or one of its electronic/electrical systems to perform without degradation of its performance in the presence of specific electromagnetic disturbance.

3.30 electronic/electrical subassembly (ESA)

electronic and/or electrical component, or an assembly of components provided for installation into an EPAC, together with all electrical connections and associated

wiring for the execution of several specific functions.

3.31 ESA test

test carried out on one or more specific ESAs.

3.32 ESA type in relation to electromagnetic compatibility

separate technical ESA unit that does not differ from other units in its essential design and construction aspects.

Note to entry: For example

- the function performed by the ESA;
- the general layout of the electronic and/or electrical components;
- direct vehicle control performed by the rider acting on the steering, the brakes and the accelerator control.

3.33 exposed protrusion

protrusion which through its location and rigidity could present a hazard to the rider either through heavy contact with it in normal use or should the rider fall onto it in an accident.

3.34 fork steerer (fork stem)

part of a fork that rotates about the steering axis of a bicycle frame head tube.

Note to entry: It is normally connected to the fork crown or directly to the fork legs, and is normally the point of connection between the fork and the handlebar stem.

3.35 fracture

unintentional separation into two or more parts.

3.36 full discharge of the battery

point at which the battery does not deliver any power/energy to the motor, according to the battery manufacturer's specifications.

3.37 highest gear

gear ratio which gives the greatest distance travelled for one rotation of the cranks.

3.38 hub-brake

brake which acts directly on the wheel-hub.

3.39 hub-generator

electric generating device built in the wheel-hub.

3.40 integrated charger

charger which is a part of the bicycle and needs tools to be disassembled from it.

3.41 electrical control system

electronic and/or electrical component, or an assembly of components provided for installation into a vehicle, together with all electrical connections and associated wiring for the engine electrical power assistance.

3.42 lowest gear

gear ratio which gives the shortest distance travelled for one rotation of the cranks

3.43 maximum inflation pressure.

maximum tyre pressure recommended by the tyre or rim manufacturer for a safe and efficient performance.

Note to entry: If the rim and tyre both indicate a maximum inflation pressure, the maximum inflation pressure is the lowest of the two pressures indicated.

3.44 maximum saddle height

vertical distance from the ground to the point where the top of the seat surface is intersected by the seat-post axis, measured with the seat in a horizontal position and with the seat-post set to the minimum insertion-depth mark.

3.45 maximum assisted speed by design

maximum designed speed up to which assistance is provided.

3.46 minimum insertion-depth mark

mark indicating the minimum insertion-depth of handlebar stem into fork steerer (fork stem) or seat-post into frame.

3.47 narrow-band emission

emission which has a bandwidth less than that of a specific receiver or measuring instrument.

3.48 no load current point

current for which there is no torque on the driving wheel.

3.49 off-road rough-terrain

coarse pebble tracks, forest trails, and other general off-road tracks where tree-roots and rocks are likely to be encountered.

3.50 pedal tread-surface

surface of a pedal that is presented to the underside of the foot.

3.51 primary retention system

system that keeps the front/rear wheel securely attached to the frame/fork dropouts whilst riding.

3.52. public road

any designated and adopted road, pavement, path or track on which a bicycle is legally permitted to travel and on most though not all such public roads, bicycles will share use with other forms of transport including motorised traffic.

3.53 pulley

rotating wheel mounted on an axle, that contains around its circumference teeth or groove over which a belt can pass to transmit power.

3.54 quick-release device

lever actuated mechanism that connects, retains, or secures a wheel or any other component.

3.55 quick-release pedal (quick-release device)

pedal that contains a device for the attachment of a rider's foot/shoe that can be released by foot-movement alone.

3.56 rated voltage

voltage declared by the manufacturer of the bicycle.

3.57 reference antenna

balanced half-wave dipole tuned to the measured frequency.

3.58 reference limit

nominal level to which both the component type-approval of the vehicle and the conformity-of-production limit value refer.

3.59 rim-brake

brake in which brake-shoes act on the rim of the wheel.

3.60 screw thread locking devices

devices attached or applied to the threads of a nut or bolt so that they do not unintentionally become unlocked.

EXAMPLE Lock washers, lock nuts, thread locking compound, or stiff nuts.

3.61 seat-post

component that clamps the saddle (with a bolt or assembly) and connects it with the frame.

3.62 secondary retention system

system that retains the front wheel in the fork dropouts when the primary retention system is in the open (unlocked) position.

3.63 suspension-fork

front fork incorporating controlled, axial flexibility to reduce the transmission of road-shocks to the rider.

3.64 suspension-frame

frame incorporating controlled, vertical flexibility to reduce the transmission of road-shocks to the rider.

3.65 toe-clip

device attached to the pedal to grip the toe end of the rider's shoe but permitting withdrawal of the shoe.

3.66 visible crack

crack which results from a test where that crack is visible to the naked eye.

3.67 wheel

assembly or combination of hub, spokes or disc, and rim, but excluding tyre assembly.

3.68 wheelbase

distance between the axes of the front and rear wheels of an unladen bicycle.

3.69 unattended station

hire location that is not supervised by qualified personal.

3.70 simulated ground plane

plane used to orient a test part or assembly in a way that represents the cycles alignment to the ground in a fully assembled cycle.

3.71 bolted joint

components joined together with threaded fastener.

3.72 anti-tampering measures

technical requirements and specifications which prevent, as far as possible,

unauthorized modifications of the EPAC's drive system which may prejudice functional safety.

3.73 maximum performance

combination of cut-off speed (3.23), maximum assisted speed by design (3.45) and continuous rated power (3.20)

3.74 motor unit

motor, gearing if integrated and control unit.

3.75 aerodynamic extension

extension (or extensions) secured to the handlebar or stem, to improve the rider's aerodynamic posture.

3.76 maximum permissible total weight

weight of the fully assembled EPAC plus rider and luggage as defined by the manufacturer

All rights reserved
Reprints must investigate

4 .Safety requirements and/or protective measures

4.1 General

EPAC shall be designed according to the principles of EN ISO 12100 for relevant but not significant hazards, which are not dealt with by this document. It includes evaluation of such risks for all relevant components.

Means shall be provided to the user to prevent an unauthorized use of the EPAC e.g. key, locks, electronic control device.

4.2 Electrical requirements

4.2.1 Electric circuit

The electrical control system shall be designed so that, should it malfunction in a hazardous manner, it shall switch off power to the electric motor without causing a hazardous situation and it requires user interaction to switch on again.

4.2.2 Controls and symbols

The electrical control system shall be designed so that, should it malfunction in a hazardous manner, it shall switch off power to the electric motor without causing a hazardous situation and it requires user interaction to switch on again.

NOTE The mechanical brakes serve as an emergency stop device and provide fast and safe stopping in emergency situations.

4.2.3 Batteries

4.2.3.1 Requirements

- a) The EPAC and batteries pack shall be designed in order to avoid risk of fire and mechanical deterioration resulting from abnormal use. Compliance is checked by the test described in 4.2.3.2.
- b) During the test the EPAC and the batteries shall not emit flames, molten metal or poisonous ignitable gas in hazardous amounts and any enclosure shall show no damage that could impair compliance with this European Standard. Safety and compatibility of the battery/charger combination shall be ensured, according to the manufacturer's specifications.
- c) The battery terminals shall be protected against creating an accidental short circuit.
- d) An appropriate care shall be taken to ensure that the batteries are protected against overcharging. An appropriate overheating and short circuit protection device shall be fitted.

NOTE Example solutions are given in Annex A.

Batteries and the charger unit shall be labelled in order to be able to check their compatibility.

4.2.3.2 Test method

Compliance with 4.2.3.1 a) is verified by the following test:

- 1) Battery terminals are short-circuited with the batteries in a fully charged condition.
- 2) Motor terminals are short-circuited; all commands are in ON position, while the batteries are fully charged.
- 3) The EPAC is operated with the electric motor or drive system blocked until the motor torque stops or the battery is fully discharged.
- 4) The battery is charged for double the recommended charging period or for 24 h whichever is greater.

NOTE Testing the battery for example according to EN 62133 or EN 50604–1 is considered as sufficient test to fulfil this requirement.

4.2.4 Battery charger

Chargers for EPAC are considered to be operated in a residential (household) environment.

NOTE 1 For integrated battery charger with a 230V a.c. input the charger and the EPAC and for external battery charger supplied with an EPAC the requirements of the Low Voltage Directive are applicable.

NOTE 2 For external chargers with d.c. output less than 42,4 Volt, e.g. EN 60335–2–29 is applicable.

4.2.5 Electric cables and connections

4.2.5.1 General

All connectors for cable and wire shall be selected to prevent corrosion of electrical contact conductance.

4.2.5.2 Requirements

Cable and plug temperature shall be lower than that specified by the manufacturer of the cables and plugs. Damage to cable and plug insulation shall be prevented.

The cable cross sections shall be selected in accordance to EN 60335-1:2012, Table 11. If these requirements are not met, a temperature rise test shall be performed, in accordance to 4.2.5.3.

NOTE Cables used exclusively for communication lines are excluded

4.2.5.3 Test method

At an ambient room temperature (20 ± 5) °C, discharge the fully charged EPAC battery to the discharging limit specified by the EPAC or ESA manufacturer at the maximum current allowable by the system and record it. Measure the cable and plug temperatures and ensure, by examination, that there is no deterioration of the insulation on either assembly.

The increase of outer surface temperature of parts that can be touched shall be ≤ 60 K while in use on performance test rig.

4.2.6 Wiring

Requirements on wiring shall be checked according to the following sequence at an ambient room temperature (20 ± 5) °C.

- a) Wire ways shall be smooth and free from sharp edges.
- b) Wires shall be protected so that they do not come into contact with burrs, cooling fins or similar sharp edges that may cause damage to their insulation. Holes in metal through which insulated wires pass shall have smooth well-rounded surfaces or be provided with bushings.
- c) Wiring shall be effectively prevented from coming into contact with moving parts. Compliance with a), b), c) shall be checked by inspection.
- d) Separate parts of the EPAC that can move in normal use or during user maintenance relative to each other, shall not cause undue stress to electrical connections and internal conductors, including those providing ground continuity.

If an open coil spring is used to protect wire, it shall be correctly installed and insulated. Flexible metallic tubes shall not cause damage to the insulation of the conductors contained within them.

Compliance with d) shall be checked by inspection and by the following test method.

If flexing occurs in normal use, the appliance is placed in its normal operational position and is supplied at rated voltage under normal operation.

The movable part is moved backwards and forwards through the largest angle permitted by its construction, so that the conductor is flexed.

For conductors that are flexed in normal use, flex movable part for 10 000 cycles at a test frequency of 0,5 Hz.

For conductors that are flexed during user maintenance, flex the movable part for 100 cycles at the same frequency.

4.2.7 Power cables and conduits

Conduit entries, cable entries and knockouts shall be constructed or located so that the introduction of the conduit or cable does not reduce the protection measures adopted by the manufacturer.

Compliance is checked by inspection. Guidance for power cables size selection is given in HD 60364-5-52:2011, Clauses 5.22.1.2, 523.1523.3 and Table A .

The insulation of internal wiring shall withstand the electrical stress likely to occur in normal use. The wiring and its connections shall withstand the electrical strength test.

The test voltage expressed in V shall be equal to $(500 + 2 \times U_r)$ for 2 min and applied between live parts and other metal parts only.

NOTE U_r is the rated voltage.

4.2.8 External and internal electrical connections

Electrical connection shall comply with HD 60364-5-52:2011, Clauses 526.1 and 526.2.

4.2.9 Moisture resistance

The electrical components of a fully assembled EPAC shall be tested least 10 minutes and shall comply IEC 60529 4.2.14 IPX4 requirements.

4.2.10 Mechanical strength test

The electrical components including the battery shall have adequate mechanical strength and be constructed to withstand such rough handling that may be expected in normal use. Compliance is checked by:

-Applying impacts to the battery pack mounted on the EPAC by means of the spring hammer as specified in EN 60068-2-75. The battery pack is rigidly supported and three impacts are applied to every point of the enclosure that is likely to be weak with an impact energy of $(0,7 \pm 0,05)$ J. After the test the battery pack shall show no damage that could lead to emission of dangerous substances (gas or liquid) ignition, fire or overheating.

-Detachable batteries are submitted to free fall on a rigid surface as specified in EN 22248 at a height of 0,90 m in three different positions. The positions shall be one surface, one edge and one corner of the enclosure that is likely to be weak.

After the test the battery pack shall show no damage that could lead to emission of dangerous substances (gas or liquid) ignition, fire or overheating.

Other standards and transportation regulation given in national and international regulations, give additional requirements for general design of the battery and battery pack.

4.2.11 Maximum speed for which the electric motor gives assistance

4.2.11.1 Requirements

The electrical motor assistance shall stop when the EPAC reaches a speed of 25 km/h or lower speed if limited by design.

The maximum speed of the EPAC for which the electric motor gives assistance shall not differ by more than +10 % from the maximum assistance speed indicated in the marking required by Clause 5 when determined according to the test method described in 4.2.11.2.

4.2.11.2 Test method

4.2.11.2.1 Test conditions

The test shall be performed either on a test track, a test bench or on a stand that keeps the motor driven wheel free of the ground.

b) The speed-measuring device used for the test shall have the following characteristics:

1) Accuracy: $\pm 2\%$;

2) Resolution: 0,1 km/h.

c) The ambient temperature shall be between 5 °C and 35 °C.

d) Maximum wind speed: 3 m/s.

e) The battery shall be fully charged according to the manufacturer instructions.

4.2.11.2.2 Test procedure

Any appropriate method for checking for this requirement is acceptable; one solution is to measure the cut-off speed, another being to measure the torque output. The following example describes the cut-off speed test.

a) Pre-condition the EPAC by running it for 5 min at 80 % of the maximum assistance speed as declared by the manufacturer.

b) Record continuously the current and note the speed at which the current drops to a value equal to or less than “no load current point”.

- c) While pedalling, ride steadily to reach a speed equal to 1,25 times (if possible by design) the maximum assistance speed as declared by the manufacturer.
- d) Verify that the noted value in b) is the no load current point.

4.2.12 Start-up assistance mode

4.2.12.1 Requirements

An EPAC can be equipped with a start-up assistance mode that operates up to a maximum speed of 6 km/h.

This mode shall be activated by the voluntary and maintained action of the user either when riding without pedalling or when the user is pushing the cycle.

4.2.12.2 Test method

4.2.12.2.1 Test conditions

- a) The test may be performed either on a test track, a test bench or on a stand that keeps the motor driven wheel free of the ground.
- b) The speed-measuring device shall have the following characteristics:
 - 1) accuracy: $\pm 2\%$;
 - 2) resolution: 0,1 km/h.
- c) The ambient temperature shall be between 5 °C and 35 °C.
- d) Maximum wind speed: 3 m/s.
- e) The battery shall be fully charged according to the manufacturer's instructions

4.2.12.2.2 Test procedure

- a) Pre-condition the EPAC by running it for 5 min at 80 % of the maximum assistance speed as declared by the manufacturer, then stop.
- b) Activate the start-up assistance mode and verify that the speed increases up to 6 km/h maximum designed speed or lower value.
- c) Verify that the speed reduces progressively to 0 km/h when the start-up assistance mode is deactivated and that the current drops to a value equal to or less than the no load current point when the motor driven wheel freewheels.
- d) Activate the start-up assistance mode and maintain it for 1 min.
- e) Verify that speed is equal to or less than 6 km/h
- f) Verify that the start-up assistance mode is activated only when the actuation of the device to initiate it is maintained.

4.2.13 Power management

4.2.13.1 Requirements

- a) When tested by the method described in 4.2.13.2 the recordings shall show that assistance shall be provided only when the cyclist pedals forward. This requirement shall be checked according to the test methods described in 4.2.13.2.3;
- b) assistance shall be cut off when the cyclist stops pedalling forward and the cut-off distance shall not exceed 2 m;
- c) If all braking devices (e.g. levers, back pedal) are equipped with cut-off switches, the cut off distance shall not exceed 5 m;
- d) the power output or assistance shall be progressively reduced (see Annex B) and finally cut off as the EPAC reaches the maximum assistance speed as designed. This requirement shall be checked according to the test methods described in 4.2.13.2;
- e) the assistance shall be progressively and smoothly managed (e.g. no hunting);
- f) two independent applying actions shall be required to start the electrical assistance mode (e.g. power switch and forward pedalling activation); a traffic caused stop (e.g. traffic lights) is not subject to this requirement;
- g) after a deactivation of the electrical assistance mode due to any hazardous electric drive malfunction, the electric drive shall not start automatically without rider intervention (pedalling is not considered as rider intervention).

4.2.13.2 Test method – Electric motor management

4.2.13.2.1 Test conditions

- a) The test may be performed either on a test track, a test bench or on a stand which keeps the motor driven wheel free of the ground;
- b) The test track shall be according to 4.2.13.2.2;
- c) The time-measuring device shall have an accuracy of $\pm 2\%$;
- d) The ambient temperature shall be between 5 °C and 35 °C;
- e) Maximum wind speed shall not exceed 3 m/s;
- f) The battery shall be fully charged according to the manufacturer's instructions;
- g) Speed measurement shall have an accuracy of $\pm 2\%$.

The test to ensure the compliance to this clause shall be adapted to the

technology used; for example:

- pedal backwards and check the no load current point (see 3.48);
or

- pedal backwards and check that no torque is delivered on the driving wheel.

For the test, the worst case conditions of gear ratio and speed shall be applied. The worst condition for speed is defined as 90 % of cut off speed (see 3.23).

4.2.13.2.2 Test track

The gradient of the track shall not exceed 0,5 %. If the gradient is less than 0,2 % carry out all runs in the same direction. If the gradient lies between 0,2 % and 0,5 % carry out alternate runs in opposite directions.

The surface shall be hard, of concrete or fine asphalt free from loose dirt or gravel. The minimum coefficient of friction between the dry surface and the bicycle tyre shall be 0,75.

4.2.13.2.3 Test procedure

- a) Pedal backwards and check that no electric motor assistance is provided. The test to ensure the compliance to this clause shall be adapted to the technology used.
- b) Check the cut off distance:
 - 1) pedal so that the EPAC reach 90 % of the cut off speed;
 - 2) stop pedalling without braking;
 - 3) measure the cut off distance;
 - 4) carry out the test three times; the result is the average of this measurement after rejection of invalid points.
- c) If braking device cut-off switches are fitted, actuate each brake device separately and verify the initiation of the cut off signal while pedalling.

4.2.14 Maximum power measurement

4.2.14.1 Measurement at the engine shaft

The maximum continuous rated power shall be measured according to EN 60034-1 when the motor reaches its thermal equilibrium as specified by the manufacturer.

NOTE Thermal equilibrium: temperatures of motor parts do not vary more than 2K per hour.

In circumstance where the power is measured directly at the shaft of the electronic motor, the result of the measurement shall be divided by 1,10 to consider the measurement uncertainty and then divided by 1,05 to include for example the transmission losses, unless the real values of these losses are determined.

4.2.15 Electro Magnetic Compatibility

4.2.15.1 Emission

The EPAC and ESA shall fulfil the requirements of Annex C.

4.2.15.2 Immunity

The EPAC and ESA shall fulfil the requirements of Annex C.

4.2.15.3 Battery charger

As an EPAC is not intended to be used while charging on the electric network, for integrated charger the whole EPAC plus integrated charger shall be tested for EMC according to the applicable standards based on the European EMC directive.

NOTE The following European Standards are applicable for battery chargers to be used in residential

environment: EN 55014-1, EN 55014-2, EN 61000-3-2, EN 61000-3-3.

4.2.16 Failure mode

4.2.16.1 Requirements

It shall be possible to ride the EPAC by pedalling even if the assistance failed.

This requirement shall be checked as described in 4.2.16.2.

4.2.16.2 Test method

- a) Remove or disconnect the battery pack,
- b) Ride the bicycle up to 10 km/h

4.2.17 Anti-tampering measure

4.2.17.1 General

Anti-tampering measures apply to tampering or modifications that general consumers carry out concerning the control unit, drive unit or other parts of power assisting system by using commercially available tools, equipment or parts.

4.2.17.2 Prevention of tampering of the motor

The following Anti-tampering requirements shall be taken into account:

- a) Anti-tampering relevant parameters indicated below shall only be accessible to the manufacturer or authorized persons and changes of software configuration parameters require programming tools that are not commercially available or security protected:
 - maximum speed with motor assistance (all systems),
 - parameters affecting the maximum vehicle speed limited by design,
 - maximum gear ratio (system with middle motors),
 - maximum motor power (all systems),
 - maximum speed of starting up assistance;
- b) Assumable manipulations on the approval relevant configuration have to be prevented or compensated by effective counter measures, i.e. plausibility logics to detect manipulations on sensors;
- c) Closed set of components (i.e. operation only with released battery);
- d) Protection against opening of relevant components without traces (sealing).

4.3 Mechanical requirements

4.3.1 General

4.3.1.1 Definition of brake tests

Brake tests to which accuracy requirements apply, as in 4.3.1.4, are those specified in 4.3.5.3 to 4.3.5.6 inclusive.

4.3.1.2 Definition of strength tests

Strength tests to which accuracy requirements apply, as in 4.3.1.4, are those involving static, impact or fatigue loading as specified in 4.3.5.6 to 4.3.12, 4.3.13 inclusive and 4.3.19.2.

4.3.1.3 Numbers and condition of specimens for the strength tests

In general, for static, impact and fatigue tests, each test shall be conducted on a new test sample, but if only one sample is available, it is permissible to conduct all of these tests on the same sample with the sequence of testing being fatigue, static and impact.

When more than one test is conducted on the same sample, the test sequence shall be clearly recorded in the test report or record of testing.

NOTE It ought to be noted that if more than one test is conducted on the same sample, earlier tests can influence the results of subsequent tests. Also, if a sample fails when it has been subjected to more than one test, a direct comparison with single testing is not possible.

In all strength tests, specimens shall be in the fully-finished condition.

4.3.1.4 Accuracy tolerances of test conditions for brake tests and strength tests

Unless stated otherwise, accuracy tolerances based on the nominal values shall be as follows:

Forces and torques	0/+5 %
Masses and weights	±1 %
Dimensions	±1 mm
Angles	±1°
Time duration	±5 s
Temperatures	±2 °C
Pressures	±5 %

4.3.1.5 Fatigue test

The force for fatigue tests is to be applied and released progressively, not to exceed 10 Hz. The tightness of fasteners according to manufacturer's recommended torque can be re-checked not later than 1 000 test cycles to allow for the initial settling of the component assembly. (This is considered applicable to all components, where fasteners are present for clamping). The test bench shall be qualified to meet dynamic requirements of 4.3.1.4.

4.3.1.6 Fatigue test for composite components

For fatigue test for composite components, the initial value of displacement (peak-to-peak value) is taken after 1000 cycles and before 2000 cycles.

4.3.1.7 Plastic material test ambient temperature

All strength tests involving any plastic materials shall be pre-conditioned for two hours and tested at an ambient temperature of $23\text{ °C} \pm 5\text{ °C}$.

4.3.1.8 Crack detection methods

Standardised methods should be used to emphasize the presence of cracks where visible cracks are specified as criteria of failure in tests specified in this standard.

NOTE For example, suitable dye-penetrant methods are specified in ISO 3452-1[18] ISO 3452-2[19] ISO 3452-3[20] and ISO 3452-4[21]. In addition, white paint or surface treatment can be used to aid in detection for composite materials.

4.3.2 Sharp edges

Exposed edges that could come into contact with the rider's hands, legs, etc., during normal riding or normal handling and normal maintenance shall not be sharp, e.g. deburred, broken, rolled or processed with comparable techniques.

NOTE Refer to ISO 13715:2000[24].

4.3.3 Security and strength of safety-related fasteners

4.3.3.1 Security of screws

Any screws used in the assembly of suspension systems or screws used to attach bracket attached electric generators, brake-mechanisms and mud-guards to the frame or fork, and the saddle to the seat-post shall be provided with suitable locking devices, e.g. lock-washers, lock-nuts, thread locking compound or stiff nuts.

NOTE 1 : The screws used to attach hub-generator are not included.

Note 2: mechanical and physical properties of bolts are specified in ISO 898-1.

4.3.3.2 Minimum failure torque

The minimum failure torque of bolted joints for the fastening of handle bars, handlebar-stems, bar-ends, saddle and seat-posts shall be at least 50 % greater than the manufacturer's recommended tightening torque.

4.3.3.3 Folding bicycles mechanism

Folding bicycle mechanism; if provided shall be designed so that EPAC can be locked for use in a simple, stable, safe way and when folded no damage shall occur to any cables. No locking mechanism shall contact the wheels or tyres during riding, and it shall be impossible to unintentionally loosen or unlock the folding mechanisms during riding.

4.3.4 Protrusions

These requirements are intended to address the hazards associated with the users of EPACs falling on projections or rigid components (e.g. handlebars, levers) on EPAC possibly causing internal injury or skin puncture. Tubes and rigid components in the form of projections which constitute a puncture hazard to the rider should be protected. The size and shape of the end protection has not been stipulated, but an adequate shape shall be given to avoid puncturing of the body. Screw threads which constitute a puncture hazard shall be limited to a protrusion length of one major diameter of the screw beyond the internally threaded mating part.

NOTE Handlebar-ends are covered by the paragraph in 4.3.6.2.

4.3.5 Brakes

4.3.5.1 Braking-systems

EPAC shall be equipped with at least two independently actuated braking-systems. At least one shall operate on the front wheel and one on the rear wheel. The braking-systems shall operate without binding and shall be capable of meeting the braking-performance requirements of 4.3.5.9.

No hand shall need to be taken from the handlebar to operate the brake levers.

If additional braking-systems are implemented, they shall meet the brake requirements of 4.3.5.

Brake-blocks containing asbestos shall not be permitted.

4.3.5.2 Hand-operated brakes

4.3.5.2.1 Brake-lever position

The brake levers for front and rear brakes shall be positioned according to the legislation or custom and practice of the country in which EPAC is to be sold, and EPAC manufacturer shall state in the manufacturer's instructions which levers operate the front and rear brakes (see also 6 i).

4.3.5.2.2 Hand-operated brakes

4.3.5.2.2.1 Requirement

The dimension, d , measured between the outer surfaces of the brake-lever in the region intended for contact with the rider's fingers and the handlebar or any other covering present shall over a distance of not less than 40 mm as shown in Figure 1 shall not exceed 90 mm;

Conformance shall be established by the method detailed in 4.3.5.2.2.2.

NOTE The range of adjustment on the brake-lever ought to permit these dimensions to be obtained.

Dimensions in millimetres

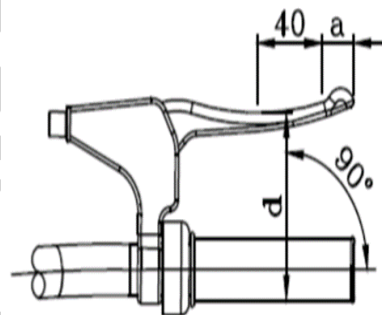

Figure 1 — Brake-lever grip dimensions

a Distance between the last part of the lever intended for contact with the rider's fingers and the end of the lever

d Brake-lever grip dimension

4.3.5.2.2.2 Test method for the brake-lever similar

Fit the gauge illustrated in Figure 2 — over the handlebar-grip or the handlebar (when the manufacturer does not fit a grip) and the brake-lever as shown in Figure 3 — so that the face A is in contact with the handlebar or grip and the side of the brake-lever. Ensure that the face B spans an area of that part of the brake-lever which is intended for contact with the rider's fingers without the gauge causing any movement of the brake-lever towards the handlebar or grip. Measure the distance a , the distance between the last part of the lever intended for contact with the rider's fingers and the end of the lever.

NOTE The measurement ought to be conducted only on a fully-assembled bicycle.

Dimensions in millimetres

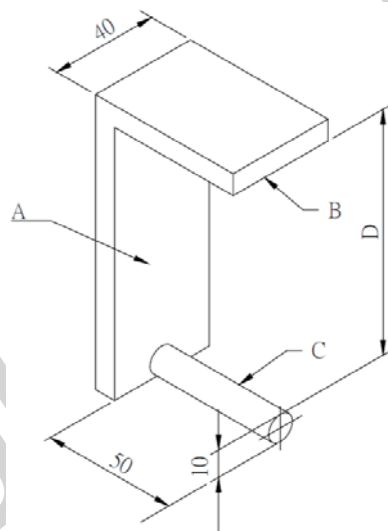

- A A Face
- B B Face
- C Rod

Figure 2 — Brake-lever grip dimension gauge

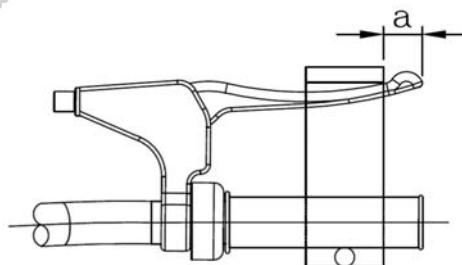

Figure 3 — Method of fitting the gauge to the brake-lever and handlebar
(Minimum grip length is shown)

4.3.5.3 Attachment of brake assembly and cable requirements

Cable pinch-bolts shall not sever any of the cable strands when assembled to the manufacturer's instructions. In the event of a cable failing, no part of the brake mechanism shall inadvertently inhibit the rotation of the wheel.

The cable end shall either be protected with a cap that shall withstand a removal force of not less than 20 N or be otherwise treated to prevent unravelling.

NOTE See 4.3.3 in relation to fasteners.

4.3.5.4 Brake-levers – Position of applied force

For the purposes of braking tests in this standard, for brake-levers similar to Type A or Type B, the test force shall be applied at a distance, b , which is equal to either dimension a (see Figure 3 — a) and b)) as determined in 4.3.5.2.2.2 or 25 mm from the free end of the brake-lever, whichever is the greater (see Figure 4).

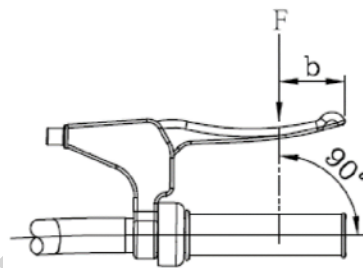

F Applied force
 b =25 mm

Figure 4 —Position of applied force on the brake-lever type A

4.3.5.5 Brake-block and brake-pad assemblies – Security test

4.3.5.5.1 Requirement

The friction material shall be securely attached to the holder, backing-plate, or shoe and there shall be no failure of the braking system or any component thereof when tested by the method specified in 4.3.5.5.2.

4.3.5.5.2 Test method

Conduct the test on a fully-assembled bicycle with the brakes adjusted to a correct position with a rider or equivalent mass on the saddle. The combined mass of the bicycle and rider (or equivalent mass) shall be 120 kg.

Actuate each brake-lever with a force of 180 N applied at the point as specified in Figure 4 — or a force sufficient to bring the brake-lever into contact with the handlebar grip, whichever is the lesser. Maintain this force while subjecting the bicycle to five forward and five rearward movements, each of which is not less than 75 mm distance.

Then conduct the test described in 4.3.5.7 or 4.3.5.8 as appropriate depending on the style of brake, and then the test described in 4.3.5.9.

4.3.5.6 Brake adjustment

Each brake shall be equipped with an adjustment mechanism either manual or automatic.

Each brake shall be capable of adjustment with or without the use of a tool to an efficient operating position until the friction material has worn to the point of requiring replacement as recommended in the manufacturer's instructions. Also, when correctly adjusted, the friction material shall not contact anything other than the intended braking surface.

The brake blocks of a bicycle with rod brakes shall not come into contact with the rim of the wheels when the steering angle of the handlebars is set at 60°, nor shall the rods bend, or be twisted after the handlebars are reset to the central position.

4.3.5.7 Hand-operated braking-system – Strength test

4.3.5.7.1 Requirement

When tested by the method described in 4.3.5.7.2, there shall be no failure of the braking-system or of any component thereof.

4.3.5.7.2 Test method

Conduct the test on a fully-assembled bicycle. After it has been ensured that the braking system is adjusted according to the recommendations in the manufacturer's instructions, apply a force to the brake-lever at the point as specified in Figures 4.

This force shall be 450 N, or such lesser force as is required to bring:

- a) a brake-lever into contact with the handlebar grip or the handlebar where the manufacturer does not fit a grip;
- b) a brake extension-lever level with the surface of the handlebar or in contact with the handlebar;

c) a secondary brake lever to the end of its travel.

Repeat the test for a total of 10 times on each brake-lever, secondary brake lever or extension lever.

4.3.5.8 Back-pedal braking system – Strength test

4.3.5.8.1 General

If the back-pedal braking system is fitted, the brake shall be actuated by the operator's foot applying force to the pedal in a direction opposite to that of the drive force. The brake mechanism shall function regardless of any drive-gear positions or adjustments. The differential between the drive and brake positions of the crank shall not exceed 60°.

The measurement shall be taken with the crank held against each position with a pedal force of at least 250 N. The force shall be maintained for 1 min in each position.

4.3.5.8.2 Requirement

When tested in accordance with 4.3.5.8.3, there shall be no failure of the brake system or any component thereof.

4.3.5.8.3 Test method

Conduct the test on a fully-assembled bicycle. After it has been ensured that the braking system is correctly adjusted, and with the pedal cranks in a horizontal position, as shown in Figure 5, apply a vertically-downward force to the centre of the left-hand pedal spindle. Increase the force progressively to 1 500 N and maintain fully for 1 min.

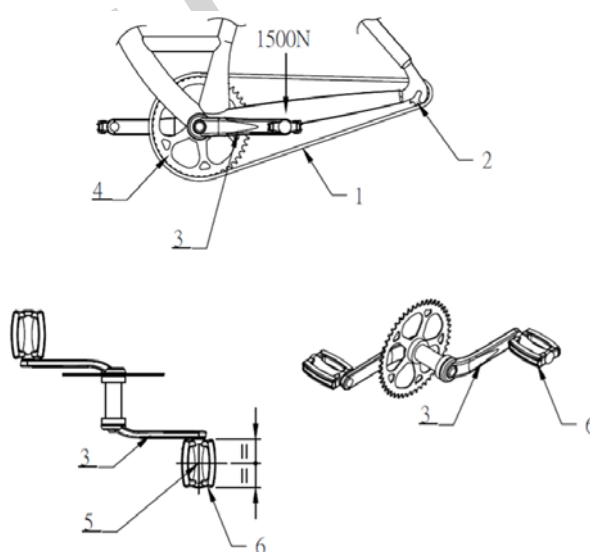

- 1 Chain
- 2 Hub sprocket
- 3 Left crank
- 4 Cycle chain-wheel and pedal crank
- 5 Point of force application
- 6 Pedal

Figure 5 — Back-pedal brake test

4.3.5.9 Braking performance

4.3.5.9.1 General

The progressive characteristics of the brake are determined by linearity measurements. A final, simple track test checks for smooth, safe, stopping characteristics.

NOTE See 4.3.5.9.5.6 h) "Test method —simple track test".

Conduct the braking-performance test on a fully-assembled bicycle after the brakes have been subjected to the strength test detailed in 4.3.5.7, 4.3.5.8. Before testing the bicycle, inflate the tyres and adjust the brakes all according to the manufacturer's instructions, but in the case of rim-brakes to the maximum clearance specified by the manufacturer.

4.3.5.9.2 Requirements

Where EPAC is fitted with secondary brake-levers attached to brake-levers, bar-ends or aerodynamic extensions, separate tests shall be conducted for the operation of the secondary brake-levers in addition to tests with the normal levers.

When tested in accordance with 4.3.5.9.5, the bicycle shall fulfil the requirements shown in Table 1.

Table 1 — Calculated braking performance value

Condition	Brake in use	the value of acceleration(m/s^2)
Dry	Front only	MTB:4.25 Other type:3.40
	Rear only	MTB:2.80 Other type:2.20
Wet	Front only	2.64
	Rear only	1.68

NOTE These values are based on the reference mass "m" (100 kg).

4.3.5.9.3 Linearity requirements

When tested by the methods described in 4.3.5.9.5.6 c) 1) and 2), the braking force *F_{Br average}* shall be linearly proportional (within $\pm 20\%$) to the progressively increasing intended operating forces *F_{Op intend}*. The requirement applies to braking forces *F_{Br average}* equal to and greater than 80 N (see Annex F).

4.3.5.9.4 Ratio between wet and dry braking performance requirements

In order to ensure safety for both wet and dry braking, the ratio of braking performance wet:dry shall be greater than 5:10.

The methods for calculating this ratio are given in 4.3.5.9.5.6 g).

4.3.5.9.5 Test method

4.3.5.9.5.1 General

The test machine enables the braking distances or deceleration for both brakes or the rear brake alone to be calculated from measurements of the individual braking forces of the front and rear brakes on a drum or belt.

4.3.5.9.5.2 Symbols

F_{Op}	Operating force (i.e. force applied on brake-lever or pedal)
$F_{Op\ intend}$	Intended operating force (e.g. 40 N, 60 N, 80 N etc.)
$F_{Op\ rec}$	Recorded operating force (e.g. 38 N, 61 N, 79 N etc.)
F_{Br}	Braking force
$F_{Br\ rec}$	Recorded braking force
$F_{Br\ corr}$	Corrected braking force (Corrected for difference between <i>F_{Op intend}</i> and <i>F_{Op rec}</i>)
$F_{Br\ average}$	The arithmetic mean of the three <i>F_{Br corr}</i> at one level of <i>F_{Op intend}</i>
$F_{Br\ max}$	The maximum <i>F_{Br average}</i>
F_{Br}^D	Dry braking-force
F_{Br}^W	Wet braking-force

4.3.5.9.5.3 Test machine

The test machine shall incorporate a system that drives the wheel under test by tyre contact and a means of measuring the braking-force, and typical examples of two types of machine are illustrated in Figure 6 and Figure 7.

Figure 6 shows a machine in which a roller drives the individual wheels, and Figure 7 shows a machine in which a driven belt contacts both wheels. Other types of machine are permitted, provided they meet the specific requirements listed below and those specified in 4.3.5.9.5.4 and 4.3.5.9.5.5.

The specific requirements are as follows:

- a) the linear surface velocity of the tyre shall be 12,5 km/h and shall be controlled within $\pm 5\%$;
- b) a means of laterally restraining the wheel under test shall be provided which does not influence the measurement of braking force;
- c) a means of laterally applying forces to the brake-levers at the point specified in Figure 4 — shall be provided, with the width of the contact on the lever not greater than 5 mm. In the case of back-pedal brake, a means of applying forces to a pedal is also required.

4.3.5.9.5.4 Instrumentation

The test machine shall be instrumented to include the following:

- a) a device to record the surface velocity of the tyre, accurate to within $\pm 2\%$;
- b) a device to record the braking force (see Figures 14 and 15, for example), accurate to within $\pm 5\%$;
- c) a device to record the operating force applied to the hand-lever or pedal, accurate to within $\pm 1\%$;
- d) a water spray system, to provide wetting of the brakes of the bicycle, consisting of a water reservoir connected by tubing to a pair of nozzles arranged as shown in Figure 8. Each nozzle shall provide a flow of water at ambient temperature of not less than 4 ml/s. The wheel shall be suitably enclosed to ensure that, in addition to the rim, any hub-or disc-brake is thoroughly wetted before a test begins;
- e) a system for loading the wheels of the bicycle against the driving mechanism (see 4.3.5.9.5.5).

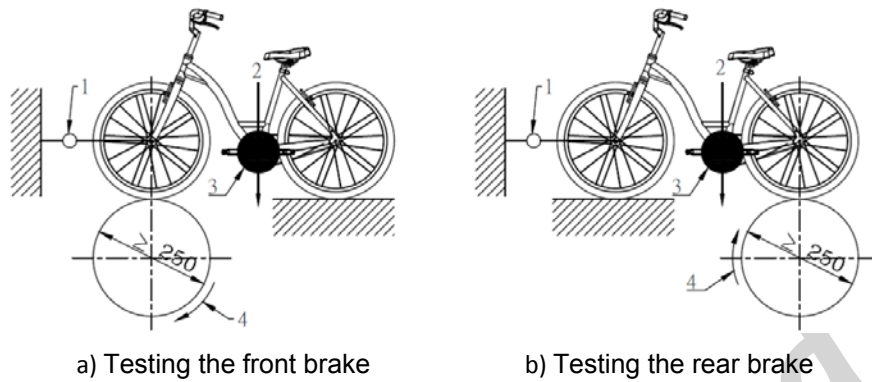

- 1 Braking-force transducer
- 2 Applied force, or
- 3 Additional mass
- 4 Direction of drum rotation

Figure 6 — Braking performance test-machine-Single drum type

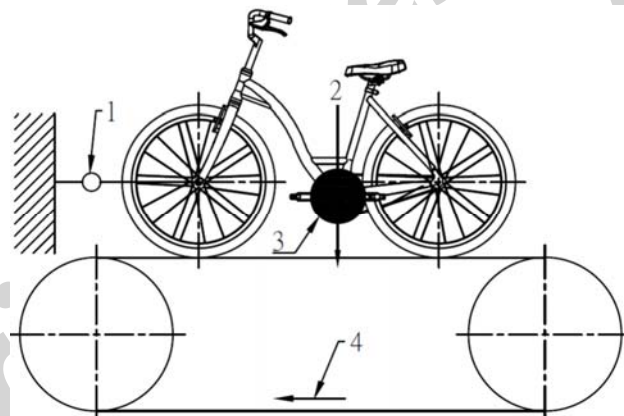

- 1 Braking-force transducer
- 2 Applied force, or
- 3 Additional mass
- 4 Direction of drum rotation

Figure 7 — Braking performance test-machine-Driven belt type

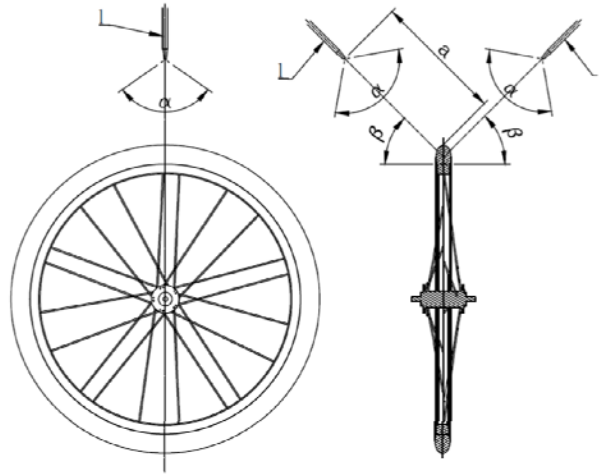

$\alpha = 90^\circ$ 至 120°

$\beta = 30^\circ$ 至 60°

$a = 150$ mm 至 200 mm

1 Water nozzles

**Figure 8 — Water nozzle arrangement for the wet braking test
(Applicable to all types of brake)**

4.3.5.9.5.5 Vertical force on the tested wheel

The wheel to be tested shall be forced vertically downwards so that no skidding of the wheel occurs when tested according to 4.3.5.9.5.6 c) 1) and 2).

NOTE It is permitted that the necessary force be applied anywhere on the bicycle (wheel-axle, bottom bracket, seat-post, etc.) provided that it is exerted vertically downwards.

4.3.5.9.5.6 Test method

a) General

Test the front and rear wheels individually.

b) Running-in the braking surfaces

Conduct a running-in process on every brake before the performance test is performed.

In order to determine the operating force to be used during the running-in process, mount and load the bicycle on the test machine with the belt or drum running at the specified speed and apply an operating force to the brake-lever or the pedal that is high enough to achieve a braking force of $200 \text{ N} \pm 10 \%$. Maintain this operating force for at least 2,5 s, and note the value of the applied operating force.

Repeat the procedure (applying the operating force determined as above accurate to within $\pm 5\%$) 10 times, or, with more repetitions if necessary, until the mean braking force from anyone of the three latest tests does not deviate by more than $\pm 10\%$ from the mean braking force from these same three tests.

c) The performance tests

1) Testing under dry conditions

For hand operated brakes, with a vertical force applied to the bicycle sufficient to prevent skidding of the tyre on the wheel under test, accelerate the driving mechanism to the specified velocity, then apply the operating-force in a series of 20 N increments from 40 N to either 180 N (in case of young adult bicycles, apply to 120 N) or to the force necessary to achieve a braking force of at least 700 N, whichever is the lesser. However, if the wheel locks, if any possible brake-overload device is actuated, or if the hand-lever comes into contact with the handlebar, do not increase the force further. For each increment of applied operating force, perform three tests within 1 min. Before applying the next level of operating force, allow the brake to cool for 1 min.

For back-pedal brakes, with a vertical force applied to the bicycle sufficient to prevent skidding of the tyre on the wheel under test, accelerate the driving mechanism to the specified velocity, then apply the operating-force in a series of 50 N increments from 100 N to either 350 N or to the force necessary to achieve a braking force of at least 400 N, whichever is the lesser. However, if the wheel locks, if any possible brake-overload device is actuated, do not increase the force further. For each increment of applied operating force, perform three tests within 1 min. Before applying the next level of operating force, allow the brake to cool for 1 min.

The applied operating forces shall lie within $\pm 10\%$ of the intended operating forces, shall be applied as specified in Figures 5 and 6 and 4.3.5.9.5.3 c), shall be recorded with an accuracy of $\pm 1\%$, and shall be fully applied within 1,0 s of the commencement of braking.

For each increment of operating force, record the braking force value, $F_{Br\ rec}$, for a period of between 2,0 s and 2,5 s, with measurement starting 0,5 s to 1,0 s after the commencement of braking. Record $F_{Br\ rec}$ as the average braking force during this measurement period.

The time at which the measurement of the braking force is started shall be related to the speed at which the operating force is applied. If the operating force is fully applied in less than 0,5 s after the commencement of braking, start the measurement after 0,5 s. However, if the operating force is fully applied between 0,5 s and 1,0 s after the commencement of braking, start the measurement when the

operating force is fully applied.

2) Testing under wet conditions

The method shall be as given in 4.3.5.9.5.6 c) 1) with the addition that wetting of the brake system shall commence not less than 5,0 s before the commencement of braking and shall continue until the measurement period has ended.

Water nozzles shall be arranged according to Figure 8.

d) Correction of braking force

Each recorded braking force, $F_{Br\ rec}$, shall be corrected for any difference between the recorded operating force and the intended operating force. The corrected braking force shall be calculated by multiplying the recorded braking force, $F_{Br\ rec}$, with a correction factor which is the ratio between the intended operating force, $F_{Op\ intend}$, and the recorded operating force, $F_{Br\ rec}$.

EXAMPLE

Recorded braking force $F_{Br\ rec} = 225\text{ N}$

Intended operating force $F_{Op\ intend} = 180\text{ N}$

Recorded operating force $F_{Op\ rec} = 184\text{ N}$

Correction factor = $180/184$

Corrected braking force $F_{Br\ corr} = 225 \times (180/184)$

e) Test results

Select from the record the maximum output braking force, $F_{Br\ max}$, for each combination of wheel (front or rear) and each test condition (wet or dry).

The braking performance value shall be calculated using the following equation:

$$B_p = F_{Br\ max} \times \frac{m}{M}$$

where

B_p is the braking performance value (N) ;

$F_{Br\ max}$ is the maximum FBr average (N) ;

m is the reference mass of EPAC defined as 100 kg for adult bicycle; 60 kg for young adult bicycles ;

M is the maximum permissible total mass specified by the manufacturer if in excess of 100 kg in 6 n) (kg);

Where a manufacturer specifies that his EPAC can carry a mass such that the sum of that mass plus the mass of EPAC is in excess of 100 kg(60 kg for young adult bicycles) to some value M , apply M as total weight.

The braking deceleration value shall be calculated using the following equation:

$$F=ma$$

$F = F_{Br\ max}$ is the maximum *FBr average* (N)

$m = EPAC + rider$ (kg)

$a =$ deceleration (m/s^2)

f) Linearity

Plot the calculated $F_{Br\ average}$ values (the arithmetic mean of the three corrected braking forces at each level of operating force) against the equivalent operating force values, $F_{Op\ intend}$, in order to assess the linearity against the requirement in 4.3.5.9.3. Plot the results on a graph, showing the line of best fit and the $\pm 20\%$ limit lines obtained by the method of least squares outlined in Annex F.

g) Ratio between wet and dry braking

Ratio between wet and dry braking For each F_{Op} where $F_{Br\ average}^D$ is > 200 N, the ratio of braking performance wet/dry shall be greater than 4:10. determine (using the following formula) whether or not the requirements of have been met:

$$F_{Br\ average}^w : F_{Br\ average}^D$$

For symbols see 4.3.5.9.5.2.

h) Simple track test (see 4.3.18).

After completion of the machine test, conduct a brief, simple track test with progressively increasing operating forces to determine whether or not the brakes bring the bicycle to a smooth, safe stop.

NOTE This test can be combined with the test on the fully-assembled bicycle.

4.3.5.10 Brakes – Heat-resistance test

4.3.5.10.1 General

This test applies to all disc-and hub-brakes but to rim-brakes only where they are known or suspected to be manufactured from or include thermoplastic materials.

Each brake on the bicycle shall be tested individually, but where the front and rear brakes are identical only one brake need be tested.

4.3.5.10.2 Requirement

Throughout the test described in 4.3.5.10.3, the brake-lever shall not touch the

handlebar-grip, the operating force shall not exceed 180 N, and the braking force shall not deviate outside the range 60 N to 115 N.

Immediately after having been subjected to the test described in 4.3.5.10.3, the brakes shall achieve at least 70 % of the braking performance which was recorded at the highest operating force used during the performance tests 4.3.5.9.5.6 c) 1) and 2).

4.3.5.10.3 Test method

Drive the wheel and tyre assembly with the brake applied on a machine such as those described in 4.3.5.9.5.3 at a velocity of 12,5 km/h \pm 5 % with a rearward, cooling air-velocity of 12,5 km/h \pm 10 %, so that a total braking energy of E Wh \pm 5 % specified in Table 2 is developed. The duration of the test shall be 15 min \pm 2 min.

Allow the brake to cool to ambient temperature and then repeat the test cycle.

A maximum of 10 interruptions per test cycle is permitted, each with a maximum duration of 10 s.

When the test has been carried out subject the brakes to the applicable parts of the tests described in 4.3.5.9.5.6 c) 1) and 2).

Calculate the braking energy from the following formula:

$$E = F_{Br} \times V_{Br} \times T (Wh)$$

where

F_{Br} is the braking force (N) ;

V_{Br} is the linear velocity of the periphery of the tyre(m/s) (12,5 km/h = 3,472 m/s) ;

T is the duration of each test cycle (h) (excluding interruptions) (如 15min = 0.25h)

Table 2 — Total braking energy

Total braking energy, E Wh	75
---------------------------------	----

When the test has been carried out, the brakes shall be subjected to the applicable parts of the test described in 4.3.5.9.5, in order to check that the requirement 4.3.5.10.2 is fulfilled.

4.3.5.11 Back-pedal brake linearity test

This test shall be conducted on a fully assembled EPAC. The output force for a back-pedal brake shall be measured tangentially to the circumference of the rear tyre, when the wheel is rotated in the direction of forward movement, while a force of between 90 N and 300 N is being applied to the pedal at right angles to the crank and in the direction of braking.

The braking force reading shall be taken during a steady pull and after one revolution of the wheel. A minimum of five results, each at a different pedal force level, shall be taken. Each result shall be the average of three individual readings at the same load level.

The results shall be plotted on a graph, showing the line of best fit and the $\pm 20\%$ limit lines obtained by the method of least squares outlined in Annex F.

All rights reserved
Reprints must investigate

4.3.6 Steering

4.3.6.1 Handlebar – Dimensions

Adjust the handlebar height to its highest normal riding position and the saddle to its lowest normal riding position as specified by the manufacturer (see 6 i)). Measure the vertical distance from the centre and top of the handlebar grips to a point where the saddle surface is intersected by the seat post axis (see Figure 9). This dimension shall not exceed 400 mm.

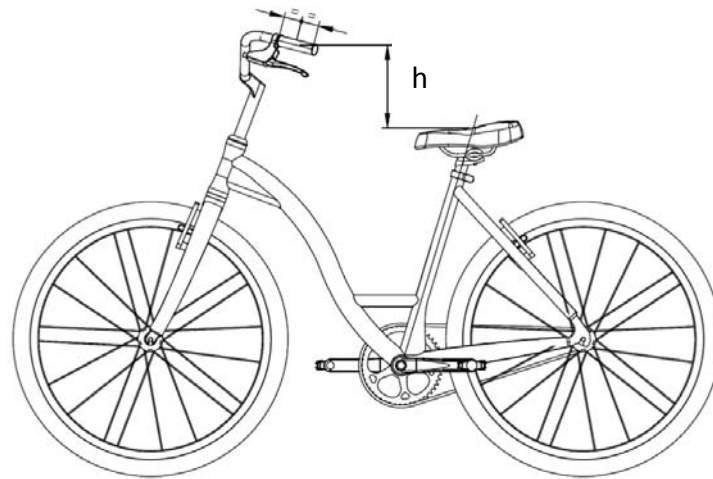

h: Vertical distance

Figure 9 — Vertical distance between the handlebar grips and the seat surface

4.3.6.2 Handlebar grips and plugs

4.3.6.2.1 Requirements

The ends of the handlebar shall be fitted with handgrips or end plugs. When tested by the method described in 4.3.6.2.2 and 4.3.6.2.3, the handgrips or plugs shall withstand the specified removal forces.

4.3.6.2.2 Freezing test method

Immerse the handlebar, with handlebar grips or plugs fitted, in water at room temperature for one hour and then place the handlebar in a freezer until the handlebar is at a temperature lower than $-5\text{ }^{\circ}\text{C}$. Remove the handlebar from the freezer and allow the temperature of the handlebar to reach $-5\text{ }^{\circ}\text{C}$, and then apply a force of 70 N to the grip or plug in the loosening direction as shown in Figure 10. Maintain the force until the temperature of the handlebar has reached $+5\text{ }^{\circ}\text{C}$.

It shall be permitted to create a hole in the plug to allow for the testing fixture to be

fitted so long as the hole does not affect the seat of the plug in the handlebar and the fixture does not contact the handlebar during the test.

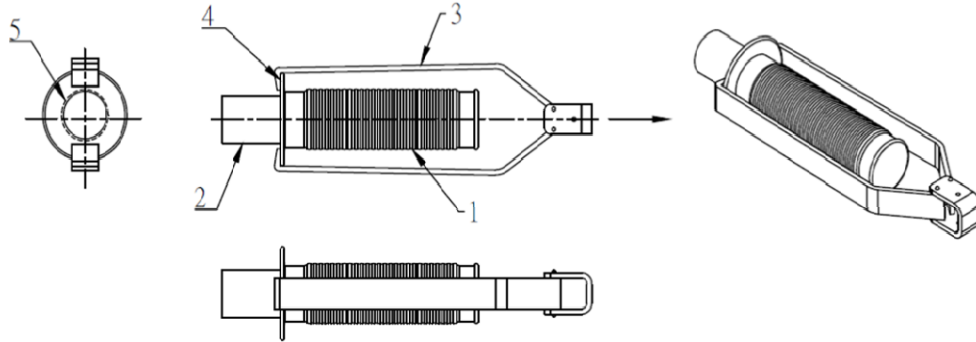

- 1 Handlebar grip
- 2 Handlebar
- 3 Drawing attachment
- 4 Hooking ring
- 5 Clearance

NOTE It is possible that the hooking ring be divided.

Figure 10 — Example of handlebar grip drawing attachment

4.3.6.2.3 Hot water test method

Immerse the handlebar, with handlebar grips fitted, in hot water of $+60\text{ °C} \pm 2\text{ °C}$ for one hour. Remove the handlebar from the hot water, allow the handlebar to stabilize at ambient temperature for 30 min, apply a force of 100 N to the grip in the loosening direction as shown in Figure 10. Maintain this force for 1 min.

4.3.6.3 Handlebar stem – Insertion-depth mark or positive stop

The handlebar-stem shall be provided with one of the two following alternative means of ensuring a safe insertion depth into the fork steerer:

- a) it shall contain a permanent, transverse mark, of length not less than the external diameter of the stem, that clearly indicates the minimum insertion depth of the handlebar-stem into the fork steerer. The insertion mark shall be located at a position not less than 2,5 times the external diameter of the handlebar-stem from the bottom of the stem, and there shall be at least one stem diameter's length of contiguous, circumferential stem material below the mark;
- b) it shall incorporate a permanent stop to prevent it from being drawn out of the fork steerer such as to leave the insertion less than the amount specified in a) above.

4.3.6.4 Handlebar stem to fork steerer – Clamping requirements

The distance g , see Figure 11, between the top of the handlebar stem and the top of the fork steerer to which the handlebar stem is clamped shall not be greater than 5 mm.

The upper part of the fork steerer to which the handlebar stem is clamped shall not be threaded.

The dimension g shall also ensure that the proper adjustment of the steering system can be achieved.

For aluminium and composite fork steerer the avoidance of any internal device that could damage the internal surface of the fork steerer is recommended.

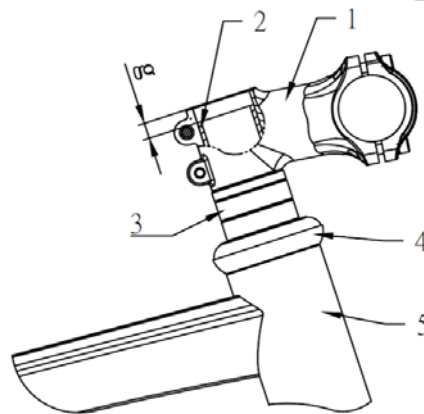

g Distance between the upper, clamping part of the handlebar stem and the upper, part of the fork steerer

1 Handlebar stem

2 Extended fork steerer

3 Spacer-rings

4 Head set

5 Head-tube

Figure 11 — Clamping between the handlebar stem and fork steerer

4.3.6.5 Steering stability

The steering shall be free to turn through at least 60° either side of the straight-ahead position and shall exhibit no tight spots, stiffness or slackness in the bearings when correctly adjusted.

A minimum of 25 % of the total mass of EPAC and rider shall act on the front wheel when the rider is holding the handlebar grips and sitting on the saddle, with the saddle and rider in their most rearward positions.

NOTE Recommendations for steering geometry are given in Annex D.

4.3.6.6 Steering assembly – Static strength and security tests

4.3.6.6.1 Handlebar and stem assembly – Lateral bending test

4.3.6.6.1.1 General

This test is for manufacturers who produce handlebars and stems or for cycle manufacturers.

4.3.6.6.1.2 Requirement

When tested by the method described in 4.3.6.6.1.3, there shall be no cracking or fracture of the handlebar, stem or clamp-bolt and the permanent deformation measured at the point of application of the test force shall not exceed 15 mm. And record the ratio between weight and rigidity in the test result.

4.3.6.6.1.3 Test method

Assemble the handlebar and stem in accordance with the manufacturer's instructions and, unless the handlebar and stem are permanently connected, e.g. by welding or brazing, align the grips portion of the handlebar in a plane perpendicular to the stem axis (see Figure 12). For stems which have a quill for insertion in to a fork steerer, clamp the quill securely in a fixture to the minimum insertion depth, or, for stem extensions which clamp directly on to an extended fork steerer attach the extension to a fork steerer according to the manufacturer's instructions and clamp this fork steerer securely in a fixture to the appropriate height. Apply a force of F_2 (Table 3) at a distance of 50 mm from the free end of the handlebar and parallel to the axis of the fork steerer as shown in Figure 12. Maintain this force for 1 min.

Table 3 – Force on handlebar

Force, F_2(N)	MTB: 1000 Other type: 800
-----------------------------------	------------------------------

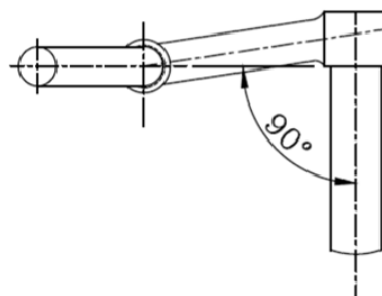

a) Orientation of adjustable handlebars

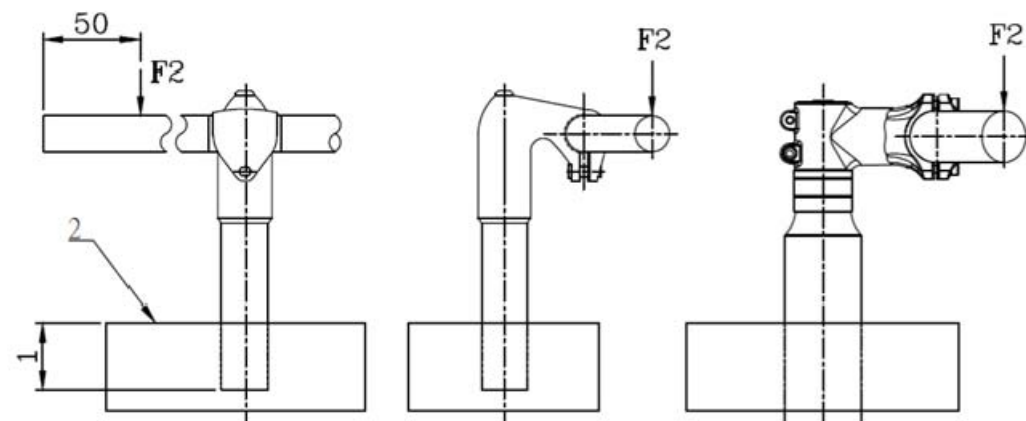

b) Combined stem and quill c) Stem extension

1 Minimum insertion depth

2 Clamping block

Figure 12 — Handlebar and stem assembly: lateral bending test

4.3.6.6.2 Handlebar -stem – Forward bending test

4.3.6.6.2.1 General

Conduct the test in two stages on the same assembly as follows.

4.3.6.6.2.2 Requirement for Stage 1

When tested by the method described in 4.3.6.6.2.3, there shall be no visible cracks or fractures and the permanent deformation measured at the point of application of the test force and in the direction of the test force shall not exceed 10 mm. And record the ratio between weight and rigidity in the test result.

4.3.6.6.2.3 Test method for Stage 1

For stems which have a quill for insertion in to a fork steerer, clamp the quill securely in a fixture to the minimum insertion depth or, for stem extensions which clamp directly on to an extended fork steerer, clamp the handlebar-stem extension securely on to a suitable, solid-steel bar and clamp the bar in securely in a fixture, the projecting length of the bar not being critical.

Apply a force F3 (Table 4) through the handlebar attachment point in a forward and downward direction and at 45° to the axis of the quill or steel bar as shown in Figure 13 and maintain this force for 1 min. Release the test force and measure any

permanent deformation.

If the handlebar-stem meets the requirement of 4.3.6.6.2.2, conduct Stage 2 of the test.

Table 4 — Force on handlebar -stem

Stage 1	force $F_3(N)$	1,600
---------	----------------	-------

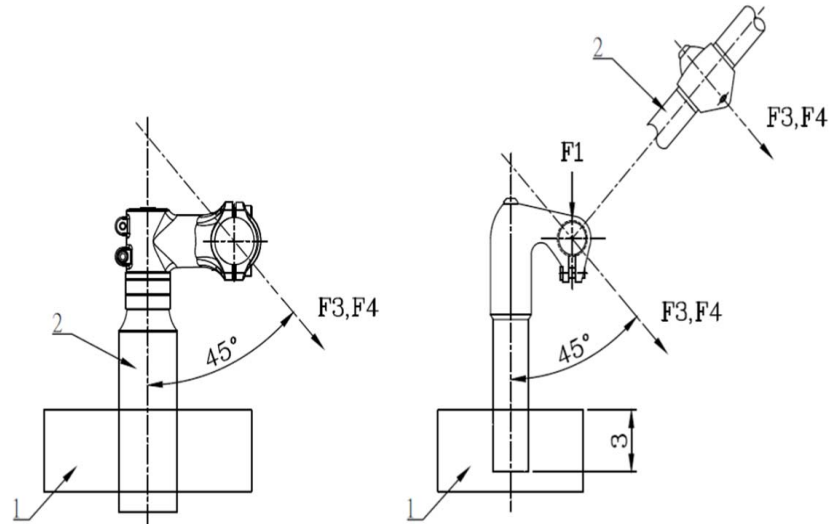

a) Stem extension b) Combined stem and quill

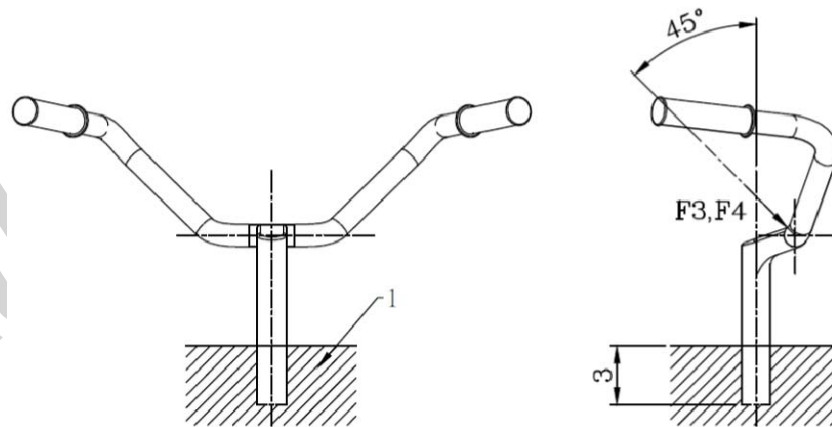

c) One piece stem-handlebar

1 Clamping fixture

2 Solid steel bar

3 Minimum insertion depth

Figure 13 — Handlebar stem: forward bending test

4.3.6.6.2.4 Requirement for Stage 2

When tested by the method described in 4.3.6.6.2.5, there shall be no visible cracks or fractures.

4.3.6.6.2.5 Test method for Stage 2

With the handlebar-stem mounted as in Stage 1, apply a progressively increasing force in the same position and direction as in stage 1 until either the force reaches a maximum of F_4 or until the handlebar-stem deflects 50 mm measured at the point of application of the test force and in the direction of the test force. If the stem does not yield or continue to yield, maintain the force for 1 min. The forces are given in Table 5.

Table 5 — Forces on stems

Stage 2	Forces F_4 (N)	2600
---------	------------------	------

4.3.6.6.3 Handlebar-stem to fork steerer – Torsional security test

4.3.6.6.3.1 Requirement

When tested by the method described in 4.3.6.6.4.2, there shall be no movement of the handlebar-stem relative to the fork steerer.

4.3.6.6.3.2 Test method

NOTE The exact method of applying the torque may vary, and an example is shown in Figure 14.

If bar-ends are fitted by the manufacturer, the test forces shall be applied to them in the test, as shown later in Figure 18a). If according to the manufacturer's instructions bar-ends may be used, simulated bar-ends (as shown in Figure 18b)) shall be used for the test.

Table 6 — Torque on handlebar

type	city and trekking bicycle	young adult bicycle	mountain-bicycle	racing-bicycle
Torque T_1 (Nm)	70	70	80	70

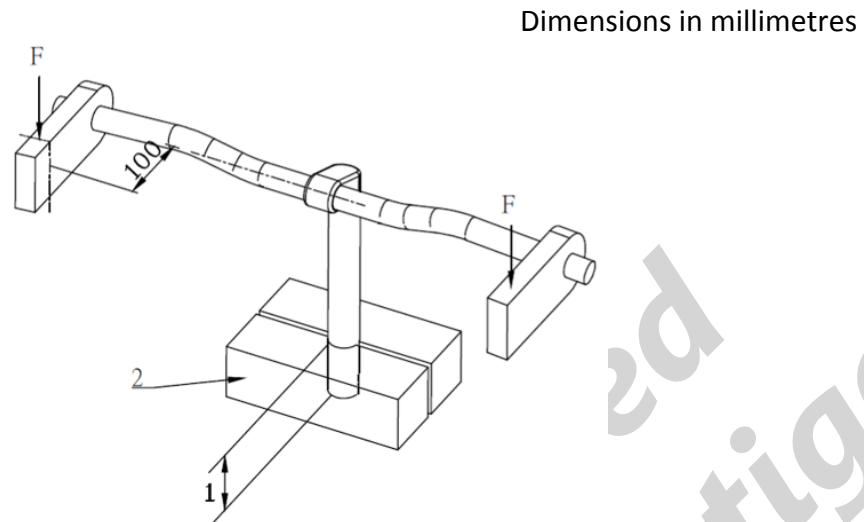

- 1 Minimum insertion depth
- 2 Clamping block

Figure 14 — Handlebar to handlebar-stem: torsional security test for applying forces to clamping block

4.3.6.6.4 Handlebar-stem to fork steerer – Torsional security test

4.3.6.6.4.1 Requirement

When tested by the method described in 4.3.6.6.4.2, there shall be no movement of the handlebar-stem relative to the fork steerer

4.3.6.6.4.2 Test method

Assemble the fork steerer correctly in the frame and attach the handlebar-stem to the fork steerer with the locking system tightened in accordance with the manufacturer's instructions, and apply a torque of T_2 once in each direction of possible rotation by applying a force on test-bar in a plane perpendicular to the axis of the fork-steerer/handlebar-stem. Maintain each torque for 1 min. The torque is given in Table 7.

NOTE The exact method of applying the torque may vary, and an example is shown in Figure 15.

Table 7 — Torque on handlebar-stem

type	city and trekking bicycle	young adult bicycle	mountain-bicycle	racing-bicycle
Torque T_2 (Nm)	40	40	50	40

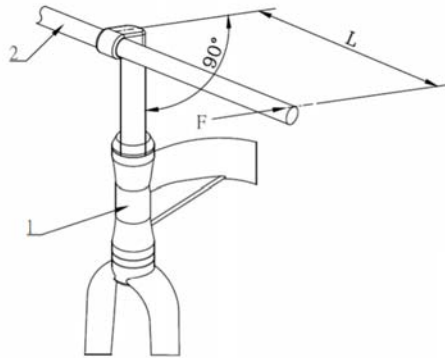

1 Frame and fork assembly
2 Solid steel bar

Figure 15 — Handlebar-stem to fork steerer: torsional security test

4.3.6.6.5 Bar-end to handlebar – Torsional security test

4.3.6.6.5.1 Requirement

When tested by the method described in 4.3.6.6.5.2, there shall be no movement of the bar-end in relation to the handlebar.

4.3.6.6.5.2 Test method

Secure the handlebar in a suitable fixture and assemble the bar-end on the handlebar tightening the fixings in accordance with the bar-end manufacturer's instructions. Apply a force of F_5 (Table 8) to follow position:

- bar-end's length is more than 100 mm, at a distance of 50 mm from the free end of the bar-end (see Figure 16 a);
- the bar-end's length is from 50 mm to 100 mm, at a distance of 50 mm from the axis of the handlebar (see Figure 16 b);
- the bar-end's length is less than 50 mm, apply a load to the mid-point of the bar end (see Figure 16 c).

Maintain this force for 1 min.

Table 8 — Forces on bar-end

type	city and trekking bicycle	young adult bicycle	mountain-bicycle	racing-bicycle
Forces F_5 (N)	300	300	500	300

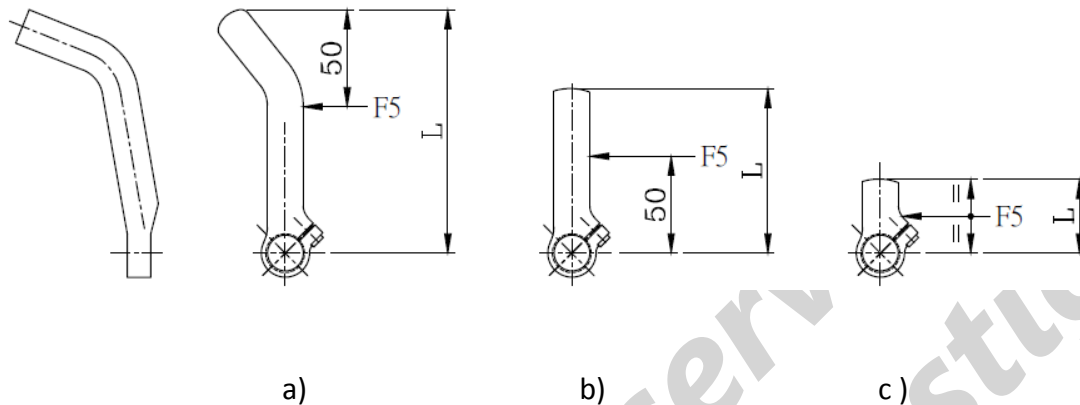

Figure 16 — Bar-end to handlebar: torsional security test

4.3.6.7 Handlebar and stem assembly – Fatigue test

4.3.6.7.1 General

Handlebar-stems can influence test failures of handlebars and for this reason, a handlebar shall always be tested mounted in a stem, but it is permitted to test a stem with a solid bar in place of the handlebar and bar-ends with dimensions corresponding to handlebars/bar-ends suitable for that stem.

When the fatigue test is for the stem only, the manufacturer of the stem shall specify the types and sizes of handlebar for which the stem is intended and the test shall be based on the most severe combination.

Conduct the test in two stages on the same assembly.

4.3.6.7.2 Requirement for Stage 1 and Stage 2

When tested by the method described in 4.3.6.7.3 or 4.3.6.7.4, there shall be no visible cracks or fractures in any part of the handlebar and stem assembly or any bolt failure.

For composite handlebars or stems, the running displacements (peak-to-peak value) at the points where the test forces are applied shall not increase by more than 20 % of the initial values.

4.3.6.7.3 Test method for Stage 1

Unless the handlebar and stem are permanently connected, e.g. by welding or brazing, align the grips of portion of the handlebar in a plane perpendicular to the stem axis (see Figure 12a)) and secure the handlebar to the stem according to the manufacturer's instructions.

Clamp the handlebar stem securely in a fixture to the minimum insertion depth, or in the case of a stem extension which is intended to be clamped to an extended fork steerer secure the extension using the manufacturer's recommended tightening procedure to an extended fork steerer which is secured in fixture to the appropriate length.

For handlebars where the manufacturer states that they are not intended for use with bar-ends, apply fully-reversed forces of F_6 at a position 50 mm from the free end each side of the handlebar for 100 000 cycles, with the forces at each end of the handlebar being out of phase with each other and parallel to the axis of the handlebar stem as shown in Figure 17a). The forces are given in Table 9. The maximum test frequency shall be maintained as specified in 4.3.1.5.

Where EPAC manufacturer fits bar-ends, fit the bar-ends to the handlebar according to the manufacturer's tightening instructions but with the bar-ends located in a plane perpendicular to the handlebar stem axis and apply the out-of-phase forces to the bar-ends, as shown in Figure 18a).

Where a handlebar manufacturer specifies that his handlebars are suitable for use with bar-ends conduct the test with the out-of-phase forces applied to simulated bar-ends as shown in Figure 18b).

If the handlebar meets the requirement of 4.3.6.7.2, remove any bar-ends and conduct Stage 2 of the test with the assembly in the same mountings.

4.3.6.7.4 Test method for Stage 2

Apply fully-reversed forces of F_7 at a position 50 mm from the free end each side of the handlebar for 100 000 cycles, with the forces at each end of the handlebar being in phase with each other and parallel to the axis of the handlebar stem as shown in Figure 17b). The maximum test frequency shall be maintained as specified in 4.3.1.5.

Table 9 — Forces on handlebars and bar-ends

Stage 1	Forces, F_6	220 N
Stage 2	Forces, F_7	280 N

Dimensions in millimetres

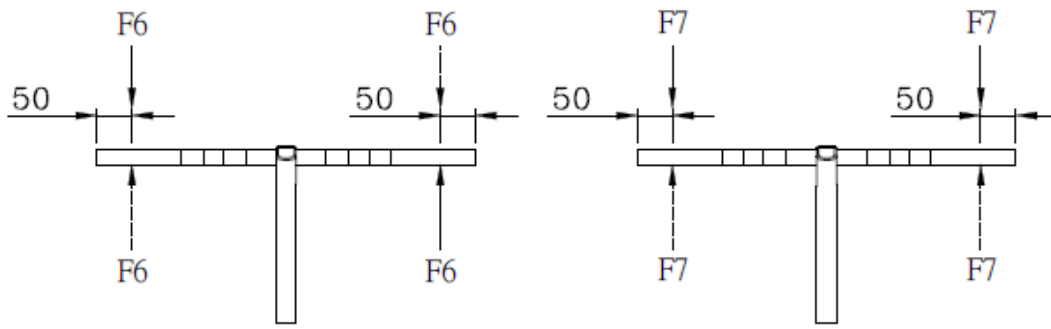

a) Stage 1 – Out-of-phase loading b) Stage 2 – In-phase loading

Figure 17 — Handlebar and stem: fatigue tests

Dimensions in millimetres

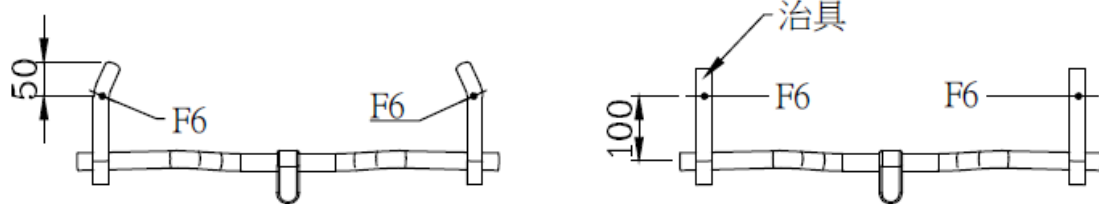

a) Test for handlebar fitted with bar-ends
(Plan view)

b) Test for handlebar intended for bar-ends
(Plan view)

Figure 18 — Handlebar incorporating bar ends: out of phase fatigue tests

4.3.7 Frames

4.3.7.1 Suspension-frames – Special requirements

The design shall be such that if the spring or damper fails, neither the tyre shall contact any part of the frame nor the assembly carrying the rear wheel become detached from the rest of the frame.

4.3.7.2 Frame – Impact test (falling mass)

4.3.7.2.1 Requirements

When tested by the method described in 4.3.7.2.3, there shall be no visible cracks or fractures of the frame. The permanent deformation measured between the axes of the wheel axles shall not exceed the following values:

- a) 30 mm where a fork is fitted;
- b) where a dummy fork is fitted in place of a fork, the values are given in Table 10.

NOTE See Annex E (normative) Dummy fork characteristics.

Table 10 — The values of permanent deformation

Fork type	Real fork	Dummy fork
Permanent deformation	30 mm	10 mm

4.3.7.2.2 General

Manufacturers of frames are permitted to conduct the test with a dummy fork (see Annex F) fitted in place of a front fork.

Where a frame is convertible for male and female riders by the removal of a bar, test it with the bar removed.

Where a suspension fork is fitted, test the assembly with the fork extended to its unloaded free length. Where a rear suspension system is incorporated in the frame, secure the suspension in a position equivalent to that which would occur with an 90 kg rider seated on the bicycle (For young adult bicycles, secure the suspension in a position equivalent to that which would occur with a 40 kg rider seated on the bicycle). If the type of suspension system does not permit it to be locked, then replace the spring/damper unit by a solid link of the appropriate size and with end fittings similar to those of the spring/damper unit.

4.3.7.2.3 Test method

4.3.7.2.3.1 Stage 1 Frame— Impact test (falling mass)

Assemble a roller of mass less than or equal to 1 kg and with dimensions conforming to those shown in Figure 19 in the fork. The hardness of roller shall be not less than 60 HRC at impact surface. If a dummy fork is used in place of a fork the bar shall have a rounded end equivalent in shape to the roller. Hold the frame-fork or frame-bar assembly vertically with clamping to a rigid fixture by the rear-axle attachment points as shown in Figure 19.

Rest a striker of mass 22,5 kg on the roller in the fork drop-outs or on the rounded end of the dummy fork and measure the wheelbase. Raise the striker to a height of h_1 above the low-mass roller and release it to strike the roller or the steel bar at a point in line with the wheel centres and against the direction of the fork rake or rake of the bar. The drop heights are given in Table 11. The striker will bounce and this is normal. When the striker has come to rest on the roller or dummy fork, measure the wheelbase again.

If the fork fails, the frame shall be tested with a dummy-fork.

Table 11— Drop heights and static energy absorption value

Type	city and trekking bicycle	young adult bicycle	mountain-bicycle	racing-bicycle
Stage 1 Drop height h_1 (mm)	360			
Stage 2 energy absorption (J)	47.6	47.6	92.3	56.1

4.3.7.2.3.2 Stage 2 Frame— Static energy absorption

With the frame and front fork assembly mounted as in 4.3.7.2.3.1 apply a progressively increasing force in the same position and direction as in 4.3.7.2.3.1, until the energy is given in Table 11. The displacement rate is 15 mm/min.

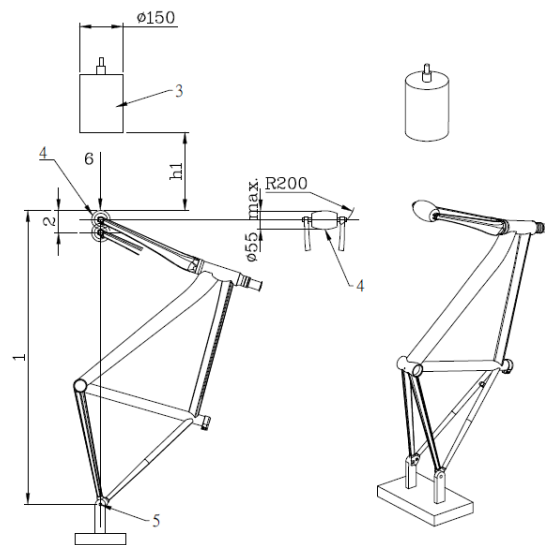

- h1 Drop height
- 1 Wheelbase
- 2 Permanent deformation
- 3 22,5 kg striker
- 4 Low mass roller (1 kg max.)
- 5 Rigid mounting for rear axle attachment point
- 6 Direction of rearward impact

Figure 19 — Frame and front fork assembly: impact test (falling mass)

4.3.7.3 Frame and front fork assembly – Impact test (falling frame)

4.3.7.3.1 General

Manufacturers of complete EPACs shall conduct the test with the frame fitted with the appropriate front fork.

Where a frame is convertible for male and female riders by the removal of a bar, test it with the bar removed.

Where a suspension fork is fitted, it shall be at its unloaded length prior to the impact. If the spring damper unit can be locked, it shall be locked in its unloaded length position. If the spring/damper cannot be locked, use one of the two following alternative procedures:

- a) secure the fork at its extended length by an external locking method, or
- b) replace the fork by a rigid fork which is known to meet the requirements of the impact test described in 4.3.8.5 and of a length which is consistent with an 90 kg rider

seated in a normal riding position on the bicycle when it is equipped with the suspension fork. (In case of young adult bicycles, apply 40 kg)

Where a rear suspension system is incorporated in the frame, secure the spring/damper unit in a position equivalent to that which would occur with an 90 kg rider seated on the bicycle; if the type of suspension system does not permit it to be locked, then replace the spring/damper unit by a solid link of the appropriate size and with end fittings similar to those of the spring/damper unit. (In case of young adult bicycles, apply 40 kg)

4.3.7.3.2 Requirement

When tested by the method described in 4.3.7.3.3, there shall be no visible cracks or fractures in the assembly and after the second impact there shall be no separation of any parts of any suspension system. The permanent deformation measured between the axes of the wheel axles shall not exceed the values specified in Table 12.

Table 11 — The values of permanent deformation

Dimensions in millimetres

Type	city and trekking bicycle	young adult bicycle	mountain-bicycle	racng-bicycle
Permanent deformation	60	60	60	15

4.3.7.3.3 Test method

4.3.7.3.3.1 Stage 1 Frame and front fork assembly — Impact test (falling frame)

Conduct the test on the assembly used for the test in 4.3.7.2.

As shown in Figure 20, mount the frame-fork assembly at its rear axle attachment points so that it is free to rotate about the rear axle in a vertical plane. Support the front fork on a flat steel anvil so that the frame is in its normal position of use. Securely fix mass $M1$ to the seat-post as shown in Figure 20 with the centre of gravity at distance D ($= 75$ mm) along the seat-post axis from the insertion point, and fix masses of $M1$, $M2$, and $M3$ (see Table 13) to the top of the steering head, the seat-post, and the bottom bracket respectively, as shown in Figure 20.

Measure the wheelbase with the three masses in place. Rotate the assembly about the rear axle until the distance between the low-mass roller and the anvil is $h2$ then allow the assembly to fall freely to impact on the anvil.

Repeat the test and then measure the wheelbase again with the three masses in place and the roller resting on the anvil.

Table 13 — Drop heights and distribution of masses at seat post, steering head, and bottom bracket

seat post, M_1 , kg		30
steering head, M_2 , kg		10
bottom bracket, M_3 , kg	Stage 1	50
	Stage 2	68
Drop height, h_2 , mm		300

4.3.7.3.3.2 Stage 2 Frame and front fork assembly — Impact test (falling frame)

With the frame and front fork assembly mounted as in 4.3.7.3.3.1, increase the 20% of total weight for each kind of bike at M_3 (see Table 13) and impact twice.

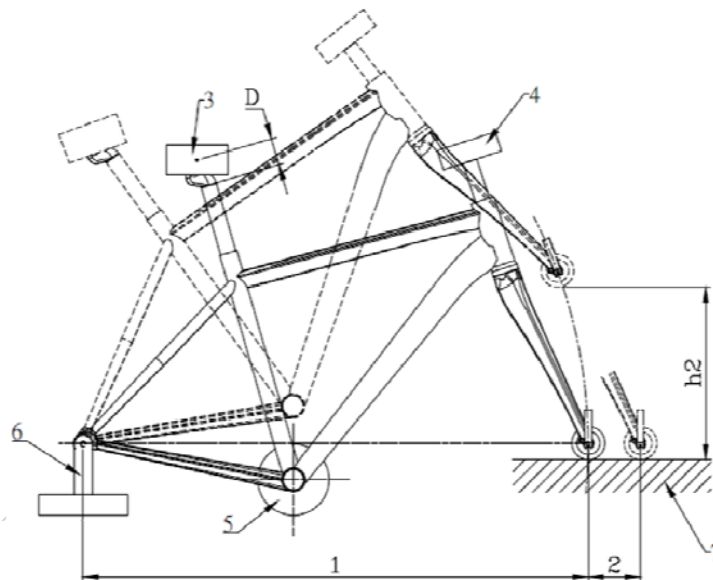

- 1 Wheelbase
- 2 Permanent deformation
- 3 Mass 1 (M_1)
- 4 Mass 2 (M_2)
- 5 Mass 3 (M_3)
- 6 Rigid mounting for rear axle attachment point
- 7 Steel anvil

Figure 20 — Frame and front fork assembly: impact test (falling frame)

4.3.7.4 Frame – Fatigue test with pedalling forces

4.3.7.4.1 General

All types of frame shall be subjected to this test.

In tests on suspension-frames with pivoted joints, adjust the spring, air-pressure, or damper to provide maximum resistance, or, for a pneumatic damper in which the air-pressure cannot be adjusted, replace the suspension-unit with a rigid link, ensuring that its end fixings and lateral rigidity accurately simulate those of the original unit. For suspension-frames in which the chain-stays do not have pivots but rely on flexing, ensure that any dampers are set to provide the minimum resistance in order to ensure adequate testing of the frame.

Where a suspension-frame has adjustable brackets or linkages to vary the resistance of the bicycle against the ground-contact forces or to vary the attitude of the bicycle, arrange the positions of these adjustable components to ensure maximum forces in the frame.

4.3.7.4.2 Requirement

When tested by the method described in 4.3.7.4.3, there shall be no visible cracks or fractures in any part of the frame, and there shall be no separation of any parts of the suspension system.

For composite frames, the running displacements (peak-to-peak values) at the points where the test forces are applied shall not increase by more than 20 % of the initial values (see 4.3.1.6).

4.3.7.4.3 Test method

4.3.7.4.3.1 Stage 1 Frame – Fatigue test with pedalling forces

Use a new frame/fork assembly fitted with standard head-tube bearings for the test. The front fork may be replaced by a dummy fork (see Annex G) of the same length and at least the same stiffness as the original fork.

If a genuine fork is used, failures of the fork are possible, therefore, it is recommended that for convenience, a dummy fork stiffer and stronger than the genuine fork is used.

Where a frame is convertible for male and female riders by the removal of a bar, test it with the bar removed.

Mount the frame assembly on a base as shown in Figure 21 with the fork or dummy fork secured by its axle to a rigid mount of height R_w (the radius of the wheel/tyre assembly ± 30 mm) and with the hub free to swivel on the axle. Secure the rear drop-outs by means of the axle to a stiff, vertical link of the same height as that of the front, rigid mount, the upper connection of the link being free to swivel about the axis of the axle but providing rigidity in a lateral plane, and the lower end of the link being fitted with a ball-joint.

Fit a crank, chain-wheel and chain assembly or, preferably, a strong, stiff, replacement assembly to the bottom bracket as shown in Figure 21 and described in a) or b) below.

a) If a crank/chain-wheel assembly is used, incline both cranks forwards and downwards at an angle of 45° (accurate $\pm 2,0^\circ$) to the horizontal and secure the front end of the chain to the middle chain-wheel of three, the smaller chain-wheel of two, or the only chain-wheel. Attach the rear end of the chain to the rear axle and perpendicular to the axis of the axle.

b) If an adaptor assembly is used (as shown in Figure 21), ensure that the assembly is free to swivel about the axis of the bottom-bracket and that both replacement arms are 175 mm long (L) and that they are both inclined forwards and downwards at an angle of 45° (accurate $\pm 2,0^\circ$) to the horizontal. Secure the position of the crank replacement arms by a vertical arm (which replaces the chain-wheel) and a tie-rod which has ball-joints at both ends and which is attached to the rear axle perpendicular to the axis of the rear axle. The length of the vertical arm (R_c) shall be 75 mm and the axis of the tie-rod shall be parallel to and 50 mm from the vertical plane through the centre-line of the frame.

Subject each pedal-spindle (or equivalent adaptor component) to a repeated downward force of F_1 at a position 150 mm from the centre-line of the frame in a vertical, transverse plane and inclined at $7,5^\circ$ (accurate to within $\pm 0,5^\circ$) to the fore/aft plane of the frame as shown in Table 14 and Figure 21 —During application of these test forces, ensure that the force on a “pedal-spindle” falls to 5 % or less of the peak force before commencing application of the test force to the other “pedal-spindle”.

Apply the test forces for 120 000 test cycles where one test cycle consists of the application and removal of the two test forces. The maximum test frequency shall be maintained as specified in 4.3.1.5.

4.3.7.4.3.2 Stage 2 Frame – Fatigue test with pedalling forces

With the frame and front fork assembly mounted as in 4.3.7.4.3.1. Apply a repeated downward force of Stage 2 as shown in Table 14 for 100 000 test cycles. The maximum test frequency shall be maintained as specified in 4.3.1.5.

Table 14 — Forces on pedal-spindle

Force in N

Type	city and trekking bicycle	young adult bicycle	mountain-bicycle	racing-bicycle
Stage 1 Force, F_1	1000	1000	1200	1100
Stage 2 Force, F_1	1100	1100	1300	1200

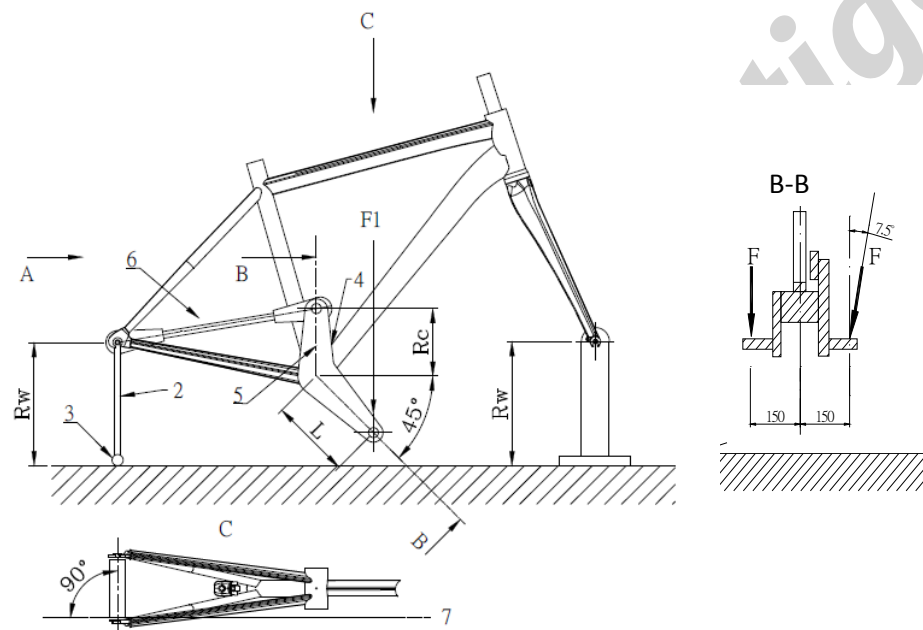

Rw Height of rigid mount and vertical link

Rc Length of vertical arm (75 mm)

L Length of crank replacement (175 mm)

1 Rigid mount

2 Vertical link

3 Ball-joint

4 Vertical arm

5 tie-rod

6 Centre-line of tie-rod

Figure 21 — Frame: fatigue test with pedalling forces

4.3.7.5 Frame – Fatigue test with horizontal forces

4.3.7.5.1 General

Where a frame is convertible for male and female riders by the removal of a bar, remove the bar.

It is not necessary for a genuine fork to be fitted, provided that any substitute fork is of the same length as the intended fork (see Annex F) and it is correctly installed in the steering-head bearings. For a suspension fork, lock it at a length equivalent to that with an 90 kg rider seated on the bicycle either by adjusting the spring/damper or by external means. (In case of young adult bicycles, apply 40 kg)

In tests on suspension frames with pivoted joints, lock the moving part of the frame into a position as would occur with a 90 kg rider seated on the bicycle. This may be achieved by locking the suspension unit in an appropriate position or, if the type of suspension system does not permit it to be locked, then the suspension system may be replaced by a solid link of the appropriate compressed size. Ensure that the axes of the front and rear axles are horizontally in line, as shown in Figure 22. For suspension-frames in which the chain-stays do not have pivots but rely on flexing, ensure that any dampers are set to provide the minimum resistance in order to ensure adequate testing of the frame.

Where a suspension frame has adjustable brackets or linkages to vary the resistance of the bicycle against the ground-contact forces or to vary the attitude of the bicycle, arrange the positions of these adjustable components to ensure maximum forces in the frame.

4.3.7.5.2 Requirement

When tested by the method described in 4.3.7.5.3, there shall be no visible cracks or fractures in the frame and there shall be no separation of any parts of any suspension system.

For composite frames, the running displacement (peak-to-peak value) at the point where the test forces are applied shall not increase by more than 20 % of the initial values (see 4.3.1.6).

4.3.7.5.3 Test method

4.3.7.5.3.1 Stage 1 Frame – Fatigue test with horizontal forces

Mount the frame in its normal attitude and secured at the rear drop-outs so that it is not restrained in a rotary sense (i.e. preferably by the rear axle) as shown in Figure 22. Ensure that the axes of the front and rear axles are horizontally in line.

Apply cycles of dynamic, horizontal forces of F_2 in a forward direction and F_3 in a rearward direction to the front fork drop-outs for C_1 cycles as shown in Table 15 and Figure 22, with the front fork constrained in vertical direction but free to move in a

fore/aft direction under the applied forces. The maximum test frequency shall be maintained as specified in 4.3.1.5.

4.3.7.5.3.2 Stage 2 Frame – Fatigue test with horizontal forces

With the frame and front fork assembly mounted as in 4.3.7.5.3.1, Apply cycles of dynamic, horizontal forces as shown in Tab.15 (stage 2).

Table 15 — Forces and cycles on front fork drop-outs

Type		MTB	Racing	Other type	
Forward force F_2 , N	Stage 1	1200	600	600	Front wheel driven EPAC
				500	Other driving systems
	Stage 2	1250	650	650	Front wheel driven EPAC
				550	Other driving systems
Rearward force F_3 , N	Stage 1	600	600	600	Front wheel driven EPAC
				500	Other driving systems
	Stage 2	650	650	650	Front wheel driven EPAC
				550	Other driving systems
Test cycles, C_1	Stage 1	60 000	120 000		
	Stage 2	50 000	100 000		

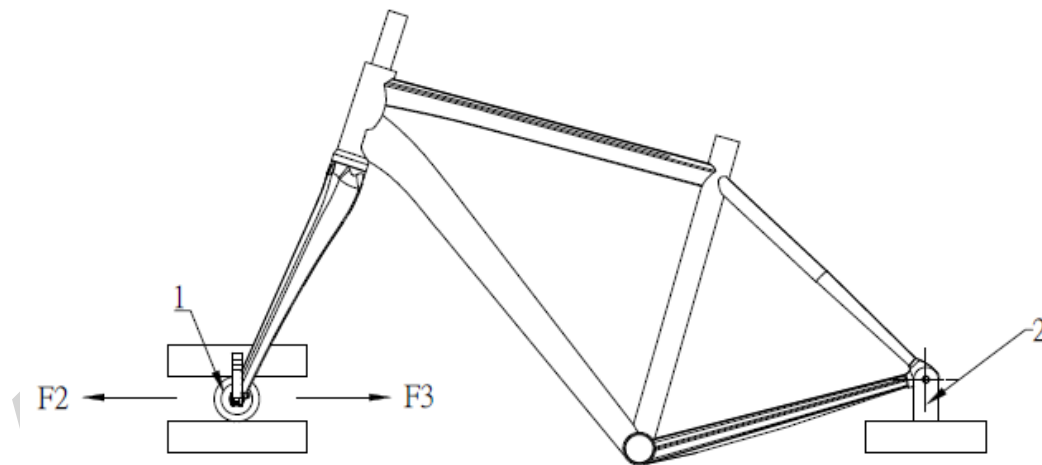

1 Free-running guided roller

2 Rigid, pivoted mounting for rear axle attachment point

Figure 22 — Frame: fatigue test with horizontal forces

4.3.7.6 Frame – Fatigue test with a vertical force

4.3.7.6.1 General

Where a frame is convertible for male and female riders by the removal of a bar, remove the bar.如果車

Where a suspension frame has adjustable brackets or linkages to vary the resistance of the bicycle against the ground-contact forces or to vary the attitude of the bicycle, arrange the positions of these adjustable components to ensure maximum forces in the frame. Secure the rear suspension as described in 4.3.7.4.1.

If a suspension fork is fitted lock it at a length equivalent to that with an 90 kg rider seated on the bicycle either by adjusting the spring/damper or by external means. (In case of young adult bicycles, apply 40 kg)

4.3.7.6.2 Requirement

When tested by the method described in 4.3.7.6.3, there shall be no visible cracks or fractures in the frame and there shall be no separation of any parts of the suspension system.

For composite frames, the running displacement (peak-to-peak value) at the point where the test forces are applied shall not increase by more than 20 % of the initial value (see 4.3.1.6).

4.3.7.6.3 test method

4.3.7.6.3.1 Stage 1 Frame – Fatigue test with a vertical force

Mount the frame in its normal attitude and secured at the rear drop-outs so that is not restrained in a rotary sense (i.e. preferably by the rear axle) as shown in Figure 23. Fit a suitable roller to the front axle in order to permit the frame to flex in a fore/aft sense under the test forces.

Insert intended seat post at minimum insertion depth or equivalent to a seat-stem to a depth of 75 mm in the top of the seat-tube and secure this to the manufacturer's instructions by the normal clamp. Securely attach a horizontal, rearward extension (E in Figure 23) to the top of this bar such that its length (dimension $h3$ in Figure 23) places Point H in a position equivalent to that of the centre of the saddle-clamp with the bicycle at its maximum saddle height recommended for the particular frame, or if the maximum saddle height information is not available dimension $h3$ shall be 250 mm.

Apply cycles of dynamic, vertically-downward forces of $F4$ at a point 70 mm behind the intersection of the axes of the solid steel bar and the extension piece, E , as shown in Figure 23 for 60 000 test cycles. The forces are given in Table 16. The maximum test frequency shall be maintained as specified in 4.3.1.5.

4.3.7.6.3.2 Stage 2 Frame – Fatigue test with a vertical force

With the frame and front fork assembly mounted as in 4.3.7.6.3.1. Apply 50000 cycles of dynamic, vertically-downward forces of stage 2 F_4 (Table 16). The maximum test frequency shall be maintained as specified in 4.3.1.5.

Table 15 — Forces on seat-stem

Type		Force in N			
		city and trekking bicycle	young adult bicycle	mountain-bicycle	racing-bicycle
Forces, F_4	Stage 1	1100	1100	1200	1200
	Stage 2	1200	1200	1300	1300

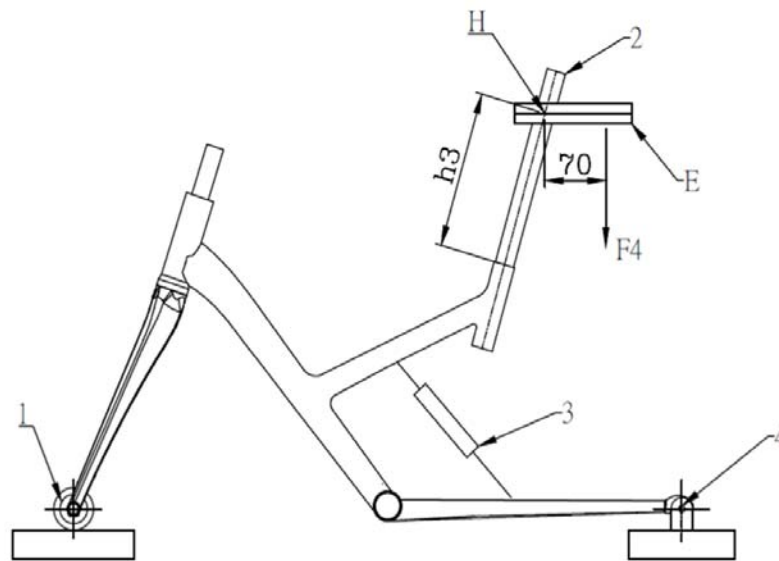

E Horizontal, rearward extension

H Position equivalent to that of the centre of the saddle-clamp with the bicycle

1 Free-running roller

2 Steel bar

3 Locked suspension unit or solid link for pivoted chain-stays

4 Rigid, pivoted mounting for rear axle attachment point

Figure 23 — Frame: fatigue test with a vertical force

4.3.8 Front fork

4.3.8.1 General

4.3.8.2, 4.3.8.4, 4.3.8.5 and 4.3.8.6 apply to all types of fork.

In the strength tests, 4.3.8.4, 4.3.8.5, 4.3.8.6 and 4.3.8.7, a suspension-fork shall be tested in its free, uncompressed length condition.

4.3.8.2 Means of location of the axle and wheel retention

The slots or other means of location for the wheel-axle within the front fork shall be such that when the axle or cones are firmly abutting the top face of the slots, the front wheel remains central within the fork.

The front fork and wheel shall also fulfil the requirements of 4.3.9.4 and 4.3.9.5.

4.3.8.3 Suspension-forks – Special requirements

4.3.8.3.1 Tyre-clearance test

4.3.8.3.1.1 Requirement

When tested by the method described in 4.3.8.3.1.2, the tyre shall not contact the crown of the fork nor shall the components separate.

4.3.8.3.1.2 Test method

For the tyre-clearance test, a suspension-fork shall first be checked and adjusted if necessary according to the items listed in following a) to f):

- a) Inflate the tyre to its maximum pressure;
- b) Place the fork in uncompressed condition to have the highest displacement between suspension stanchion legs and suspension lower legs;
- c) If the suspension-fork can be locked, place the fork in the open position;
- d) If the fork has a spring adjust device, place it in the softest position;
- e) If the fork has a pneumatic device, blow up the one or the two chambers at their minimum pressures according the manufacturer's instruction;
- f) If the fork has a rebound device, place it on the slowest position. With a wheel and tyre assembly fitted to the fork, apply a force of 2 800 N to the wheel in a direction towards the fork-crown and parallel to the axis of the fork steerer. Maintain this force for 1 min.

4.3.8.3.2 Tensile test

4.3.8.3.2.1 Requirement

When tested by the method described in 4.3.8.3.2.2, there shall be no detachment or loosening of any parts of the assembly and the tubular, telescopic components of any fork-leg shall not separate under the test force.

4.3.8.3.2.2 Test method

Mount the fork steerer securely in a suitable rigid mount, keeping any clamping forces away from the fork-crown, and apply a tensile force of 2 300 N distributed equally between the two drop-outs in a direction parallel to the axis of the fork steerer and in the direction away from the fork-crown. Maintain this force for 1 min.

4.3.8.4 Front fork – Static bending test

4.3.8.4.1 Requirement

When tested by the method described in 4.3.8.4.2, there shall be no fractures or visible cracks in any part of the fork, and the permanent deformation, measured as the displacement of the axis of the wheel-axle or simulated axle in relation to the axis of the fork steerer, shall not exceed 10 mm.

And record the ratio between weight and rigidity in the test result.

4.3.8.4.2 Test method

Mount the fork according to Annex G and fit a loading-attachment and swivel on an axle located in the axle slots of the blades (see Figure 24). Locate a deflection measuring device over the loading-attachment in order to measure deflection and permanent deformation of the fork perpendicular to the steerer axis and in the plane of the wheel.

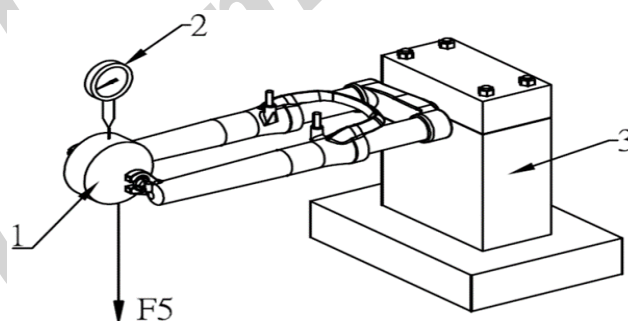

- 1 Loading attachment swivel on axle
- 2 Deflection measuring device
- 3 Rigid mount incorporating head bearings

Figure 24 — Front fork: static bending test (typical arrangement)

Apply a static, pre-loading force of 100 N to the roller perpendicular to the steerer axis, against the direction of travel, and in the plane of the wheel. Remove and repeat this loading until a consistent deflection reading is obtained. Adjust the deflection measuring device to zero.

Increase the static force to F_5 and maintain this force for 1 min, then reduce the force to 100 N and record any permanent deformation. The forces are given in Table 17.

Table 17 — Forces on loading attachment

Forces, F_5	1 500 N
---------------	---------

4.3.8.5 Front fork – Rearward impact test

4.3.8.5.1 Forks made entirely of metal

4.3.8.5.1.1 Crown/steerer joint assembled by welding or brazing

When tested by the method described in 4.3.8.5.3, there shall be no fractures or visible cracks in any part of the fork, and the permanent deformation, measured as the displacement of the axis of the wheel-axle or simulated axle in relation to the axis of the fork steerer, shall not exceed 45 mm. If the fork meets these criteria then it shall be subjected to a second test as described in 4.3.8.5.4 b), after which, it shall exhibit no fractures, then it shall be subjected to a third test as described in 4.3.8.5.4 c), irrespective of the amount of permanent deformation, there shall be no relative movement between the steerer and the crown.

If the fork is used in the frame impact test (falling-mass), 4.3.7.2, there is no need to perform this test.

4.3.8.5.1.2 Crown/steerer joint assembled by press-fitting, bonding, or clamping

When tested by the method described 4.3.8.5.4 a), if there are any fractures or visible cracks in any part of the fork, and the permanent deformation, measured as the displacement of the axis of the wheel-axle or simulated axle in relation to the axis of the fork steerer, exceeds 45 mm, the fork shall be considered to have failed. If the fork meets these criteria then it shall be subjected to a second test as described in 4.3.8.5.4 b), after which, it shall exhibit no fractures, then it shall be subjected to a third test as described in 4.3.8.5.4 c), irrespective of the amount of permanent deformation, there shall be no relative movement between the steerer and the crown.

4.3.8.5.2 Forks which have composite parts

When tested by the method described in 4.3.8.5.3, there shall be no fractures in any part of a fork and the permanent deformation, measured as the displacement of the

axis of the wheel-axle or simulated axle in relation to the axis of the fork steerer, shall not exceed 45 mm. After which, it shall exhibit no fractures, then it shall be subjected to a second test as described in 4.3.8.5.4 c) Torque on fork, irrespective of the amount of permanent deformation, there shall be no relative movement between the steerer and the crown.

4.3.8.5.3 Test method 1

Mount the fork according to Annex G as shown in Figure 25. Assemble a roller of mass less than or equal to 1 kg and with dimensions conforming to those shown in Figure 26 in the fork. The hardness of the roller shall be not less than 60 HRC at impact surface.

Rest a striker of mass $22,5 \text{ kg} \pm 0,1 \text{ kg}$ on the roller in the fork drop-outs such that it is exerting a force against the direction of travel and in the plane of the wheel. Position a deflection measuring device under the roller and record the position of the roller in a direction perpendicular to the axis of the fork steerer and in the plane of the wheel and note the vertical position of the fork.

Remove the deflection measuring device, raise the striker through a height of h_4 and release it to strike the roller against the rake of the fork. The drop heights are given in Table 18. The striker will bounce and this is normal. When the striker has come to rest on the roller, measure the permanent deformation under the roller.

Table 18 — Drop heights

Type	Forks made entirely of metal	Forks which have composite parts		
		MTB	Racing	Other type bicycles
Drop height, h_4	360 mm	600 mm	640 mm	360 mm

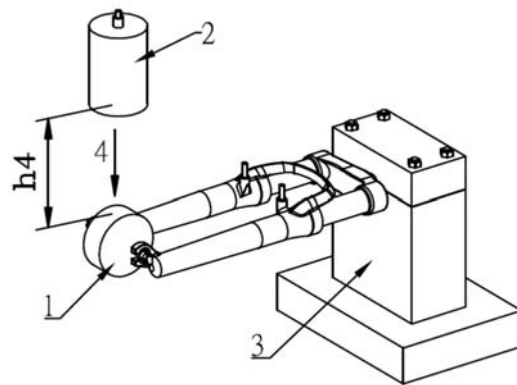

$h4$ Drop height

- 1 Low-mass roller (1 kg max)
- 2 22,5 kg striker
- 3 Rigid mount incorporating head bearings
- 4 Direction of rearward impact

Figure 25 — Front fork: rearward impact test

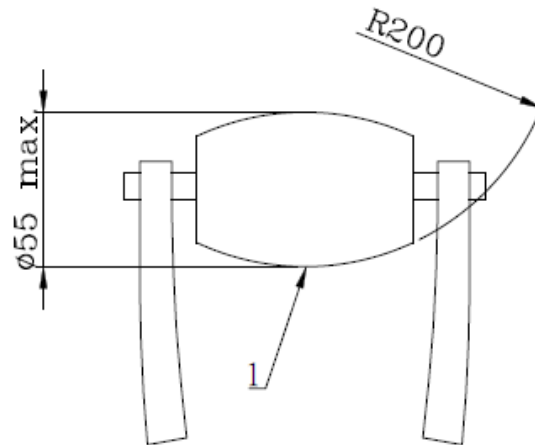

- 1 Low-mass roller (1 kg max)

Figure 26 — Low-mass roller

4.3.8.5.4 Test method 2

- a) This test is described in 4.3.8.5.3
- b) This test is similar to that described in 4.3.8.5.3 except that the dropping height shall be increased to 600 mm instead that given in Table 18. The section applies to forks in 4.3.8.5.1.2.
- c) Apply a torque of T_3 to the assembly and maintain for 1 min in each direction of possible rotation about the steerer axis. The torque is given in Table 19, and a typical example of test equipment is illustrated in Figure 27.

Table 19 — Torque on fork

Torque, T_3	80 Nm
---------------	-------

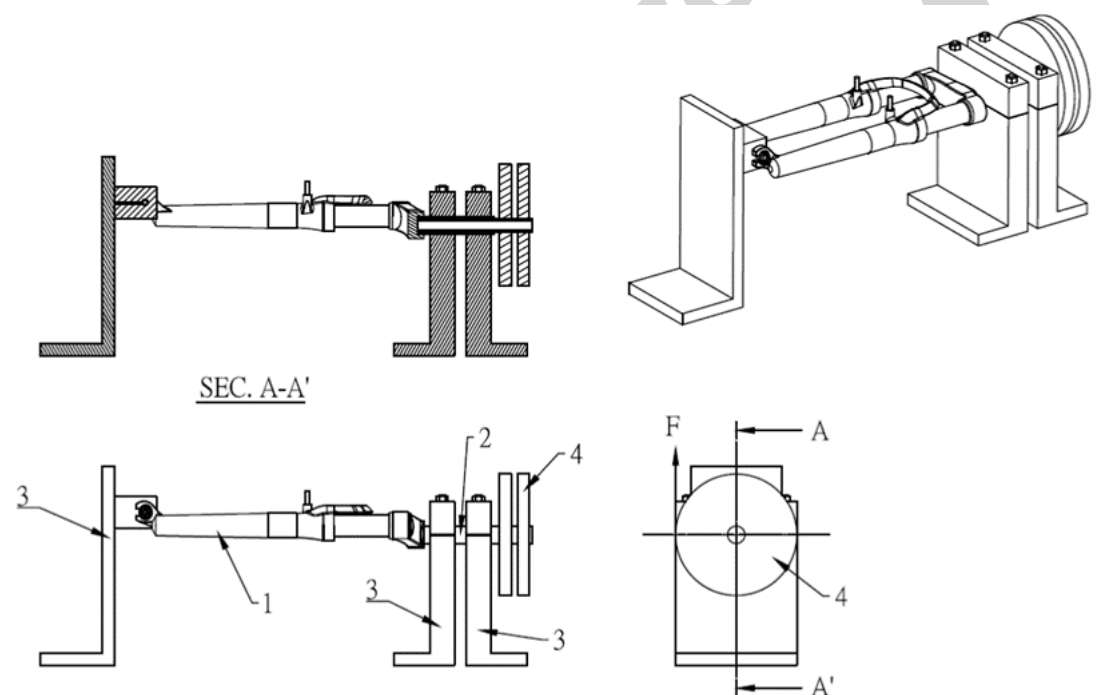

- 1 Front fork
 2 Fork mounting fixture (Fixture representative of the head-tube)
 3 Rigid mount
 4 Test adaptor

Figure 27 — Fork steerer torsional test (a typical example)

4.3.8.6 Front fork – Bending fatigue test plus rearward impact test

4.3.8.6.1 Requirement

When tested by the method described in 4.3.8.6.2, there shall be no fractures in any part of the fork, and the permanent deformation, measured as the displacement of the axis of the wheel-axle or simulated axle in relation to the axis of the fork steerer, shall not exceed 45 mm.

For composite forks, the running displacement (peak-to-peak value) at the points where the test forces are applied shall not increase by more than 20 % of the initial values (Suspension-forks shall not increase by more than 40 % of the initial values.) (see 4.3.1.6).

4.3.8.6.2 Test method

Mount the fork according to Annex G as shown in Figure 28.

4.3.8.6.2.1 Stage 1 Front fork – Bending fatigue test

Apply cycles of fully-reversed, dynamic forces of F_6 in the plane of the wheel and perpendicular to the fork steerer tube to a loading attachment and swivel on an axle located in the axle-slots of the blades for 120 000 test cycles. The forces are given in Table 20. The maximum test frequency shall be maintained as specified in 4.3.1.5.

Conclude the test if the running displacement (peak-to-peak value) at the point where the test forces are applied increases by more than 20 % for rigid forks or more than 40 % for suspension forks from the initial values.

Stop the test after 120 000 cycles and inspect the sample carefully for fractures. If fractures are found, conclude the test.

If the sample completes 120 000 cycles without exceeding the displacement limits noted above, and if no fractures or can be observed, perform the impact resistance test described in 4.3.8.5 (The drop heights are given in Table 18). When the striker has come to rest on the roller, measure the permanent deformation under the roller and inspect the sample carefully for fractures.

4.3.8.6.2.2 Stage 2 Front fork – Bending fatigue test

With the same mounted as in 4.3.8.6.2.1. Apply cycles of fully reversed, dynamic forces for 100 000 test cycles. The forces are given in Table 20.

If the sample completes 100000 cycles bending fatigue test without exceeding the displacement limits noted above, and if no fractures can be observed, perform the impact resistance test described in 4.3.8.5 (the drop heights are given in Table 18). When the striker has come to rest on the roller, measure the permanent deformation under the roller and inspect the sample carefully for fractures.

Table 20 — Forces on loading attachment

Type		MTB	Racing	Other type bicycles
Forces, F_6(N)	Stage 1	± 650	± 620	± 500
	Stage 2	± 700	± 670	± 550

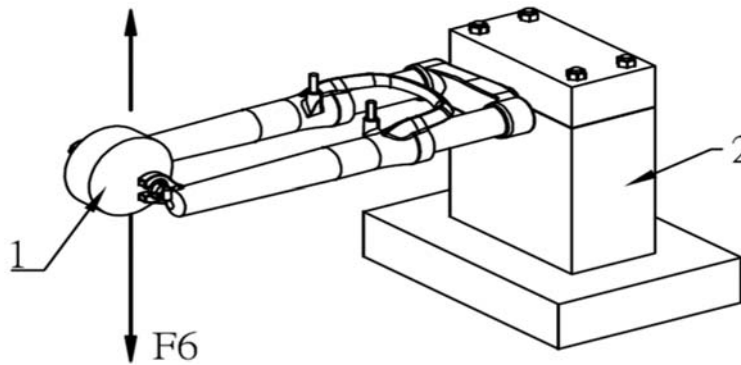

- 1 Pivoted force attachment
2 Rigid mount incorporating head bearings

Figure 28 — Front fork: bending fatigue test

4.3.8.7 Forks intended for use with hub-or disc-brakes

4.3.8.7.1 General

When a fork is intended for use with a hub-or disc-brake and whether supplied as original equipment or as an accessory, the fork manufacturer shall provide an attachment point on the fork-blade for the torque-arm or calliper.

In tests conducted by the methods described in 4.3.8.7.3 and 4.3.8.7.5 and where more than one mounting-point is provided for a hub-or disc-brake, the following shall apply:

- a) Where a complete EPAC is supplied, the test adaptor shall be secured to the mounting-point used on EPAC. If bracket will supplied, it shall be used to perform the test;
- b) Where a fork is supplied as an accessory with more than one mounting-point, separate tests shall be conducted on each of the mounting-points on separate forks.

4.3.8.7.2 Static brake-torque test

When tested by the method described in 4.3.8.7.3, there shall be no fractures or visible cracks in any part of the fork.

4.3.8.7.3 Fork for hub/disc-brake – Static brake-torque test

Mount the fork in a fixture representative of the head-tube according to Annex G and gripped in the normal head-bearings, fit an axle to the fork, and mount on the axle a pivoted, straight adaptor as shown in Figure 29 to provide a torque-arm of L_2 in length (see Table 21) and a suitable attachment for the brake mounting-point. If the wheel size is not listed in Table 21, the length L_2 shall be equal to one half of the wheel diameter.

Apply a rearward force of 1 000 N to the torque arm perpendicular to the fork steerer axis and in the plane of the wheel. Maintain this force for 1 min, then reduce the force to 100 N and record any permanent deformation.

Table 21 — Fixture length

Wheel dimension	24"	26"	650b	29"或 700c
Arm length, L_2 (mm)	305	330	349	368

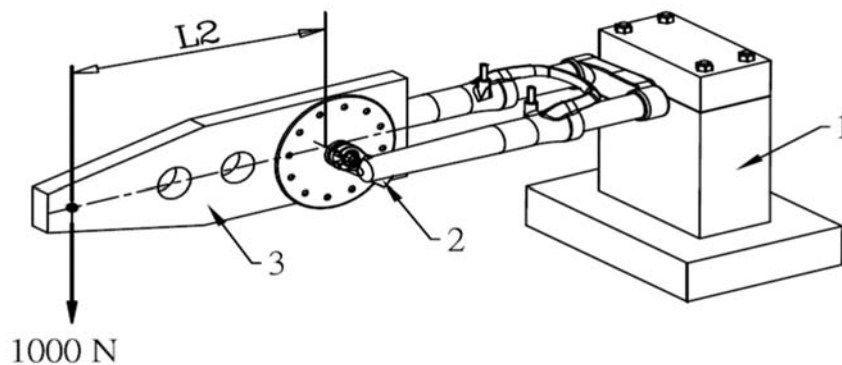

- 1 Rigid mount incorporating head bearings
- 2 Brake mounting-point
- 3 Test adaptor

Figure 29 — Fork for hub/disc-brake: static brake-torque test

4.3.8.7.4 Fork for hub/disc-brake – Brake mount fatigue test

When tested by the method described in 4.3.8.7.5, there shall be no fractures or visible cracks in any part of the fork and, in the case of suspension-forks, there shall be no separation of any parts.

4.3.8.7.5 Fork for hub/disc-brake – Brake mount fatigue test

4.3.8.7.5.1 Stage 1 Fork for hub/disc-brake – Brake mount fatigue test

Mount the fork in a fixture representative of the head-tube according to Annex G and gripped in the normal head-bearings, fit an axle to the fork, and mount on the axle a pivoted, straight adaptor as shown in Figure 30 to provide a torque-arm of L_2 in length (see Table 21) and a suitable attachment for the brake mounting-point.

Apply repeated, horizontal, dynamic forces of 600 N rearward to the end of the torque-arm parallel to the plane of the wheel (as shown in Figure 30) for C_2 cycles (see Table 22). The maximum test frequency shall be maintained as specified in 4.3.1.5.

4.3.8.7.5.2 Stage 2 Fork for hub/disc-brake – Brake mount fatigue test

With the same mounted as in 4.3.8.7.5.1. Apply repeated, dynamic forces of 700 N rearward to the end of the torque arm, for Stage 2 C_2 cycles (see Table 22). The maximum test frequency shall be maintained as specified in 4.3.1.5.

Table 22 — test cycles

Type		city and trekking bicycle	young adult bicycle	mountain-bicycle	racing-bicycle
Test cycles, C_2	Stage 1	14 400	14 400	14 400	24 000
	Stage 2	12 000	12 000	12 000	20 000

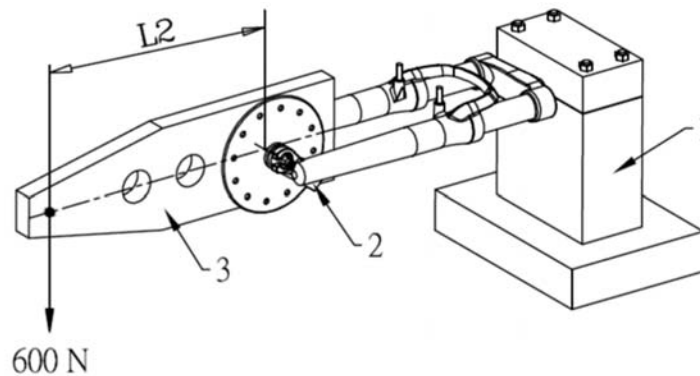

- 1 Rigid mount incorporating head bearings
- 2 Brake mounting-point
- 3 Test adaptor

Figure 30 — Fork for hub/disc-brake: Brake mount fatigue test

4.3.8.8 Tensile test for a non-welded fork

4.3.8.8.1 General

This test is for forks where the blades and/or the fork steerer are secured in the fork-crown by press-fitting, clamping, adhesives, or any method other than brazing or welding.

NOTE It may be convenient to combine this test with the wheel retention test, 4.3.9.4.2.

4.3.8.8.2 Requirement

When tested by the method described in 4.3.8.8.3, there shall be no detachment or loosening of any parts of the assembly.

4.3.8.8.3 Test method

Mount the fork steerer securely in a suitable rigid mount, keeping any clamping forces away from the fork-crown, and apply a tensile force of 5 000 N distributed equally to both drop-outs for 1 min in a direction parallel to the axis of the fork steerer.

4.3.9 Wheels and wheel/tyre assembly

4.3.9.1 Wheels/tyre assembly – Concentricity tolerance and lateral tolerance

4.3.9.1.1 Requirements

When measured by the method described in 4.3.9.1.2, the run-out shall not exceed the values which are given in Table 22.

Table 22 — Wheel/tyre assembly – Concentricity and lateral tolerance

Type		Dimensions in millimetres		
		city and trekking bicycle	young adult bicycle	mountain-bicycle
Concentricity and lateral tolerance	ntended for rim-brakes	0.8		0.6
	Not intended for rim-brakes	0.8		0.6

4.3.9.1.2 Test method

The run-out tolerances represent the maximum variation of position of the rim when measured perpendicular to the axle at a suitable point along the rim (see Figure 31-1) (i.e. full indicator reading) of a fully assembled and adjusted wheel during one complete revolution about the axle without axial movement. Both sides of the rim shall be measured and the maximum value shall be taken as result.

For City and trekking bicycle , young adult bicycle and mountain-bicycle measurement of both axial run-out (lateral) and radial run-out (concentricity) shall be done with a tyre fitted and inflated to the maximum inflation pressure, but for rims where concentricity cannot be measured with the tyre fitted, it is permissible to make measurements with the tyre removed.

For racing bicycles, the measurement of both axial run-out (lateral) and radial run-out (concentricity) shall be measured at the same time as shown in Figure 31-2 and a tyre is not required to be fitted.

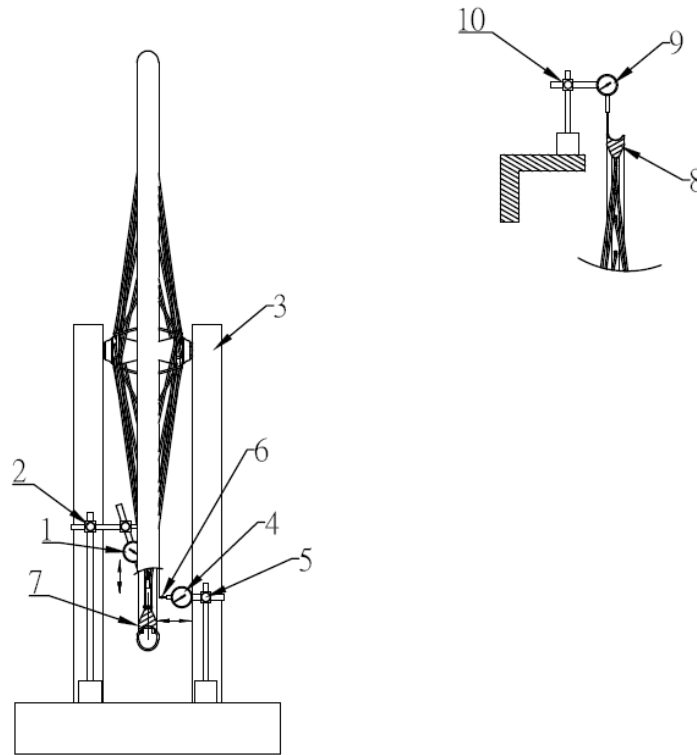

- | | |
|--------------------------------|---|
| A Rim with tyre | 5 Instrument stand |
| B Rim without tyre | 6 Roller indicator |
| 1 Dial-gauge (concentricity) | 7 Rim with tyre |
| 2 Instrument stand | 8 Rim without tyre |
| 3 Hub axle support | 9 Dial-gauge (concentricity) (alternative position) |
| 4 Dial-gauge (lateral run-out) | 10 Instrument stand |

Figure 31-1 — Wheels/tyre assembly: rotational accuracy

(City and trekking bicycle , young adult bicycle and mountain-bicycle)

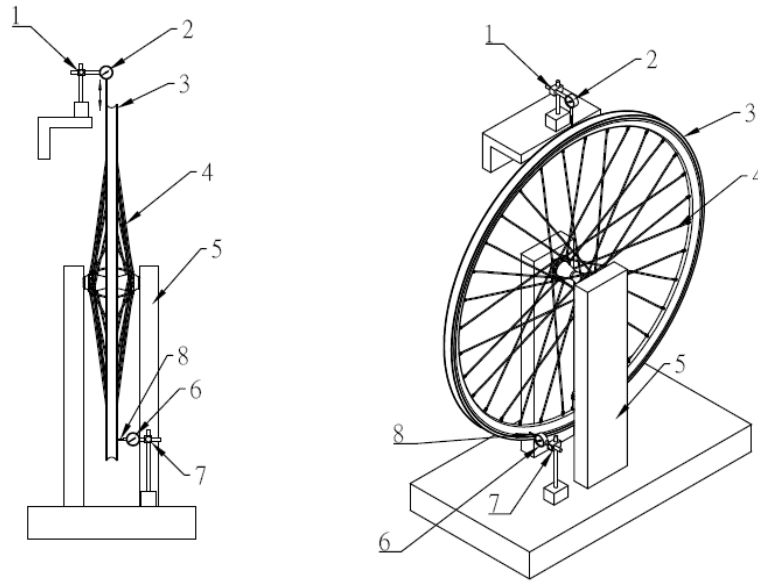

- 1 Instrument stand
- 2 Dial-gauge (concentricity)
- 3 rim
- 4 spoke

- 5 Hub axle support
- 6 Dial-gauge (concentricity)
- 7 Instrument stand
- 8 Roller indicator

Figure 31-2 — Wheels/tyre assembly: rotational accuracy
(racing bicycle)

4.3.9.2 Wheel/tyre assembly – Clearance

Alignment of the wheel assembly in EPAC shall allow not less than the clearance values given in Table 23 between the tyre and any frame or fork element or a front mudguard and its attachment bolts.

Table 23 — Wheel/tyre assembly – Clearance

Type	Dimensions in millimetres			
	city and trekking bicycle	young adult bicycle	mountain-bicycle	racing-bicycle
Clearance	6			4

NOTE Where EPAC has a frame or a fork with a suspension system, the values in Table 23 apply to the suspension system in its uncompressed state. Clearance requirements for the frame or fork under a load are specified in 4.3.8.3.1.

4.3.9.3 Wheel/tyre assembly – Static strength test

4.3.9.3.1 Requirement

When a fully assembled wheel fitted with a tyre inflated to the maximum inflation pressure is tested by the method described in 4.3.9.3.2, there shall be no failure of any of the components of the wheel, and the permanent deformation, measured at the point of application of the force on the rim, shall not exceed the values which are given in Table 24.

Table 24 — The values of permanent deformation

Type	Dimensions in millimetres			
	city and trekking bicycle	young adult bicycle	mountain-bicycle	racing-bicycle
Permanent deformation	1.35	1.35	0.9	0.9

4.3.9.3.2 Test method

Clamp and support the wheel suitably as shown in Figure 32. Apply a pre-load of 5 N on the rim at one spoke perpendicular to the plane of the wheel as shown in Figure 32. Record the zero position of the rim at the point of load application as shown. Then apply a static force of F given in Table 25 for a duration of 1 min. Reduce the load to 5 N and allow a 1 min settling time. After this settling time and with the 5 N load still applied, re-measure the position of the rim.

The wheel shall be fitted with the appropriate size tyre and inflated to the maximum pressure, determined by the lowest value between maximum inflation pressures

recommended on the rim or the tyre.

In the case of a rear wheel, apply the force from the sprocket side of the wheel as shown in Figure 32.

Repeat the above measurement once between two spokes.

Table 25 — Forces on rim

Type	Force in N			
	city and trekking bicycle	young adult bicycle	mountain-bicycle	racing-bicycle
Force, F	250	250	370	250

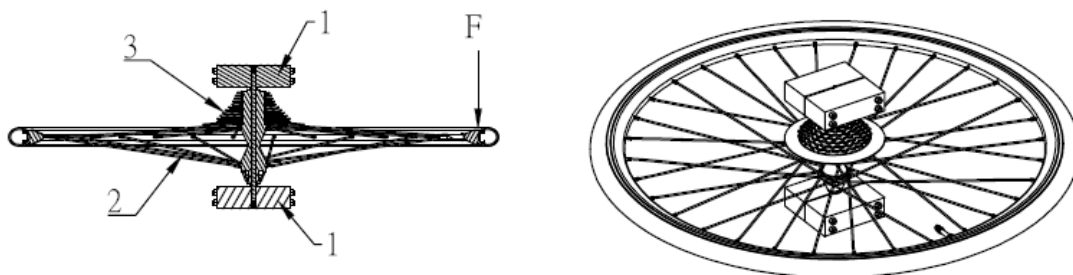

- 1 Clamping fixture
- 2 Wheel/tyre assembly
- 3 Drive sprockets

Figure 32 — Wheel/tyre assembly – Static strength test

4.3.9.4 Wheels – Wheel retention

4.3.9.4.1 General

Wheel retention safety is related to the combination of wheel, retention device, and drop-out design.

Wheels shall be secured to EPAC frame and fork such that when adjusted to the manufacturer's instructions they comply with 4.3.9.4.2, 4.3.9.4.3 and 4.3.9.5.

Wheel nuts shall have a minimum removal torque of 70 % of the manufacturer's recommended tightening torque.

Where quick-release axle devices are used they shall comply with 4.3.9.5.

4.3.9.4.2 Wheel retention – Retention devices secured

4.3.9.4.2.1 Requirement

When tested by the method described in 4.3.9.4.2.2, there shall be no relative motion between the axle and the front fork/frame.

4.3.9.4.2.2 Test method

Apply a force of 2 300 N distributed symmetrically to both ends of the axle for a period of 1 min in the direction of the removal of the front and rear wheel independently.

4.3.9.4.3 Front wheel retention – Retention devices unsecured

EPAC shall be equipped with secondary retention system that retains the front wheel in the dropouts when the primary retention system is in the open (unlocked) position.

Where threaded axles and nuts are fitted, and the nuts are unscrewed by at least 360° from the finger tight condition and the brake system disconnected or released, the wheel shall not detach from the front fork when a force of 100 N is applied radially outwards, in line with the drop-out slots, and maintained for 1 min. Where quick-release is fitted, and the quick-release lever is fully open and the brake system is disconnected or released, the wheel shall not detach from the front fork when a force of 100 N is applied to the wheel radially outwards, in line with the drop-out slots, and maintained for 1 min.

4.3.9.5 Wheels – Quick-release devices – Operating features

Any quick-release device shall have the following operating features:

- a) it shall be adjustable to allow setting for tightness;
- b) its form and marking shall clearly indicate whether the device is in the open or locked position;
- c) if adjustable by a lever, the force required to close a properly set lever shall not exceed 200 N and, at this closing force there shall be no permanent deformation of the quick-release device;
- d) the releasing force of the clamping device when closed shall not be less than 50 N;
- e) if operated by a lever, the quick-release device shall withstand without fracture or permanent deformation a closing force of not less than 250 N applied with the adjustment set to prevent closure at this force;
- f) the wheel retention with the quick-release device in the clamped position shall be in accordance with 4.3.9.4.2, 4.3.9.4.3;
- g) the front wheel retention with the quick-release device in the open position shall be in accordance with 4.3.9.4.3.

If applied to a lever, the forces specified in c), d), and e) shall be applied 5 mm from the tip end of the lever.

4.3.10 Rims, tyres and tubes

4.3.10.1 General

Non-pneumatic tyres are excluded from the requirements of 4.3.10.2 and 4.3.10.3.

4.3.10.2 Tyre inflation pressure

The maximum inflation pressure recommended by the manufacturer shall be permanently marked on the side wall of the tyre so as to be readily visible when the latter is assembled on the wheel. If the rim manufacturer recommends a maximum tyre inflation pressure, it shall be clearly and permanently marked on the rim and also specified in the manufacturer's instructions.

It is recommended that the minimum inflation pressure specified by the tyre manufacturer also be permanently marked on the side wall of the tyre.

4.3.10.3 Tyre and rim compatibility

Tyres that comply with the requirements of ISO 5775-1 and rims that comply with the requirements of ISO 5775-2 are compatible. The tyre, tube and tape shall be compatible with the rim design. When inflated to 110 % of the maximum inflation pressure, determined by the lower value between maximum inflation pressures recommended on the rim or the tyre, for a period of not less than 5 min, the tyre shall remain intact on the rim.

4.3.10.4 Rim-wear

In the case where the rim forms part of a braking system and there is a danger of failure due to wear, the manufacturer shall make the rider aware of this danger by durable and legible marking on the rim, in an area not obscured by the tyre, (see also 6 z) and 5.1).

NOTE A symbol referring to the instruction manual is an acceptable marking for rims for wear.

Where the rim is made of composite materials, the manufacturer shall include in the manufacturer's instructions warnings of the danger of rim failure caused by wear of the braking surfaces.

4.3.10.5 Greenhouse effect test for composite wheels

4.3.10.5.1 General

This requirement is to ensure wheels made from composite materials that are subjected to high temperature conditions (i.e. such as car storage in direct sunlight) do not suffer concealed damage that could subsequently affect the safety performance of the wheel during normal use.

4.3.10.5.2 Requirement

When a fully assembled wheel made of composite material, fitted with the appropriate size tyre and inflated according to the lowest value between maximum inflation pressure recommended on the rim or the tyre, is tested by the method described as 4.3.10.5.3, there shall be:

- no failure of any of the components of the wheel;
- no tyre separation from the rim during the test;
- no increase in rim width greater than 2% of the initial maximal width value;
- compliance of lateral and concentricity tolerance according to 4.3.9.1;
- compliance of tyre and rim compatibility according to 4.3.10.3;
- compliance of static strength according to 4.3.9.3

4.3.10.5.3 Test method

A fully assembled wheel, fitted with the appropriate size tyre and inflated according to the lowest value between maximum inflation pressure recommended on the rim or the tyre, has to be controlled before the test; lateral run-out has to be controlled according to 4.3.9.1 and maximum width of the rim have to be reported.

A specific bench as shown in Figure 34 could be used to measure the maximum width all around the rim with tyre and pressure (continuous measuring).

The wheel is laid down on the ground of a climate chamber pre heated at 80 °C, leant on axle and tyre support points, sprocket side of the wheel as shown in

Figure 33, during 4 h. At the end of the 4 h, the wheel should be taken out of the climate chamber and let cool down at room temperature during 4 h to re-measuring the rim width and its conformance to 4.3.10.5.1 and 4.3.10.5.2.

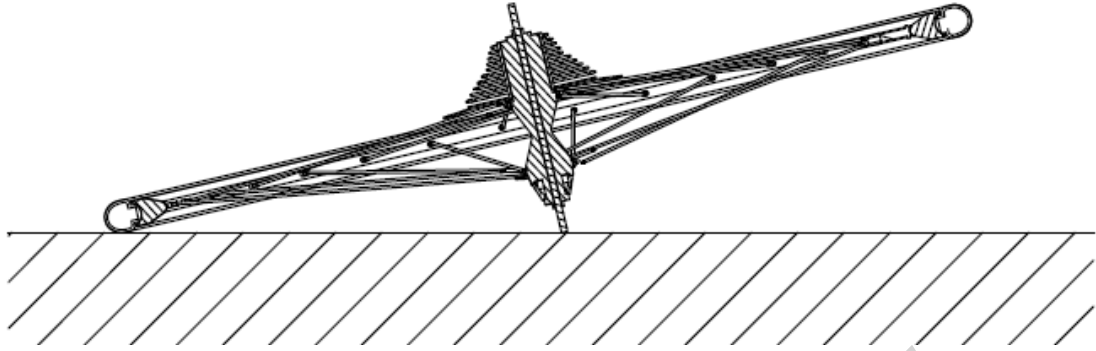

Figure 33 — Wheel laid down on tire and axle

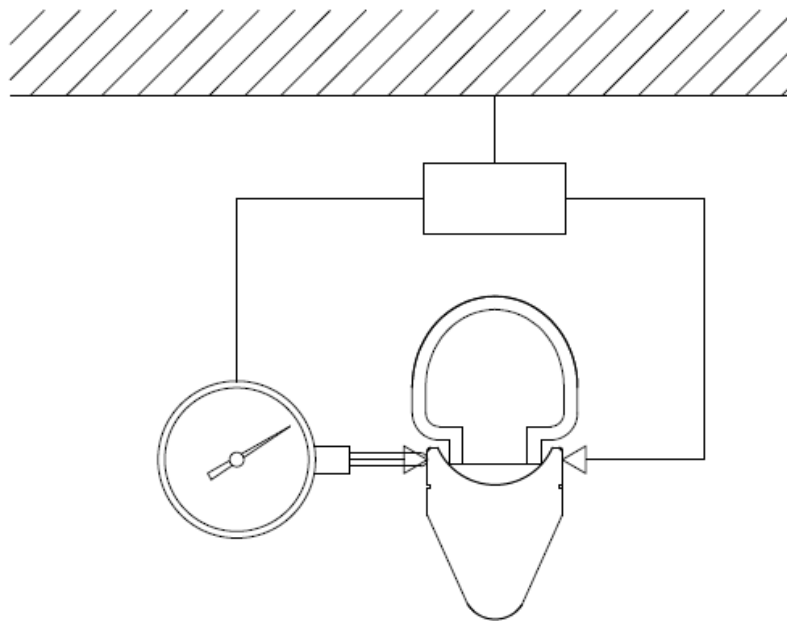

Figure 34 — Maximum rim's width measuring

4.3.11 Front mudguard

4.3.11.1 Requirements

If front mudguard is fitted, when tested by the method described in the two-stage tests in 4.3.11.2 (for mudguard with stays) or 4.3.11.3 (for mudguard without stays), the front mudguard shall not prevent rotation of the wheel or shall obstruct the steering.

4.3.11.2 Front mudguard with stays test methods

4.3.11.2.1 Stage 1: Test method – Tangential obstruction

Insert a 12 mm diameter steel rod between the spokes, in contact with the rim and below the front mudguard stays as shown in Figure 35, and rotate the wheel to apply a tangentially-upward force of 160 N, against the front mudguard stays and maintain this force for 1 min.

Remove the rod and determine whether or not the wheel is free to rotate and whether or not any damage to the front mudguard adversely affects wheel rotation (blocking of the wheel) and the steering.



Figure 35 — Front mudguard: tangential obstruction test

4.3.11.2 Stage 2: Test method – Radial force

Press the front mudguard at a distance of 20 mm from its free end (not taking the flap into consideration) with a 20 mm diameter, flat-ended tool radially towards the tyre with a force of 80 N as shown in Figure 36.

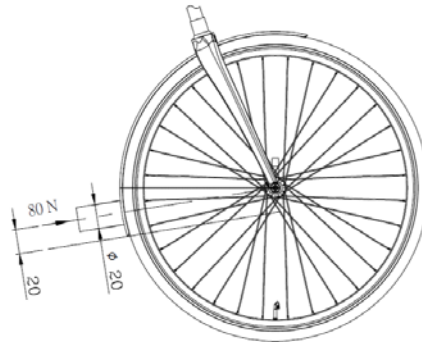

Figure 36 — Front mudguard: radial force test

While the force is maintained, rotate the wheel manually in the direction of forward movement of the bicycle and determine whether or not the wheel is free to rotate, and whether or not any damage to the front mudguard adversely affects wheel rotation (blocking of the wheel) and the steering.

4.3.11.3 Front mudguard without stays test methods

Press the front mudguard at a distance of 20 mm from its free end with a 20 mm diameter, flat-ended tool radially towards the tyre with a force of 80 N as shown in Figure 36.

While the force is maintained, rotate the wheel manually in the direction of forward movement of the bicycle and determine whether or not the front mudguard is rolled up the wheel, and whether or not any damage to the front mudguard adversely affects wheel rotation (blocking of the wheel) or obstructs the steering. Contact between tyre and mudguard is allowed.

4.3.12 Pedals and pedal/crank drive system

4.3.12 Pedal tread

4.3.12.1 Tread surface

The tread surface of a pedal shall be secured against movement within the pedal assembly.

4.3.12.1.2 Toe Clips

Pedals intended to be used without toe-clips, or for optional use with toe-clips, shall have:

- a) tread surfaces on the top and bottom surfaces of the pedal; or
- b) a definite preferred position that automatically presents the tread surface to the rider's foot.

Pedals designed to be used only with toe-clips or shoe-retention devices shall have toe-clips or shoe-retention devices securely attached and need not comply with the requirements of 4.3.12.1.2 a) and b).

4.3.12.2 Pedal clearance

4.3.12.2.1 Ground clearance

With EPAC un-laden, the pedal at its lowest point and the tread surface of the pedal parallel to the ground and uppermost where it has only one tread surface, EPAC shall be capable of being leaned over at an angle of θ from the vertical before any part of the pedal touches the ground. The values are given in Table 26.

When EPAC is equipped with a suspension system, this measurement shall be taken with the suspension adjusted to the softest condition and with EPAC depressed into a position such as would be caused by a rider weighing 90 kg (in case of young adult bicycles, apply 40 kg).

Table 26 — The values of ground clearance

Angle in degrees

Lean angle θ	25
---------------------	----

4.3.12.2.2 Toe clearance

EPACs shall have at least C clearance between the pedal and front tyre or mudguard (when turned to any position). The clearance shall be measured forward and parallel to the longitudinal axis of EPAC from the centre of either pedal-axle to the arc swept by the tyre or mudguard, whichever results in the least clearance (see Figure 37). The values are given in Table 27.

Table 27 — The values of toe clearance

Dimensions in millimetres		
Toe clearance C	without foot retention	100
	with foot retention	89
NOTE Foot retention system, e.g. quick-release pedal or toe-clip		

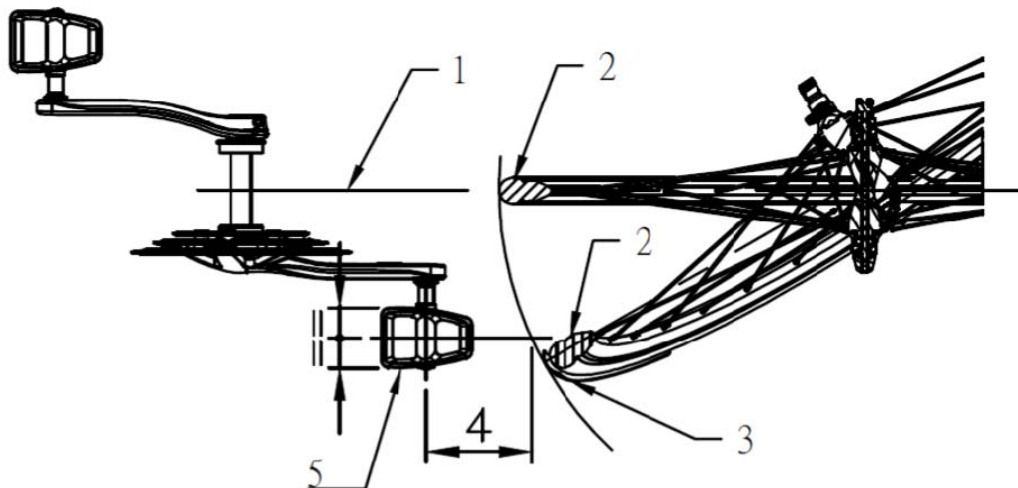

- 1 Longitudinal axis
- 2 Front tyre
- 3 Mudguard
- 4 Clearance C
- 5 Pedal

Figure 37 — Pedal to wheel/mudguard: toe clearance

4.3.12.3 Pedal – Static strength test

4.3.12.3.1 Requirement

When tested by the method described in 4.3.12.3.2, there shall be no fractures, visible cracks, or distortion of the pedal or spindle that could affect the operation of the pedal and pedal-spindle.

4.3.12.3.2 Test method

Screw the pedal-spindle securely into a suitable rigid fixture with its axis horizontal, as shown in Figure 38, and apply a vertically-downward force $1500N$ for 1 min to the centre of the pedal as shown in Figure 38. Release the force and examine the pedal assembly and the spindle.

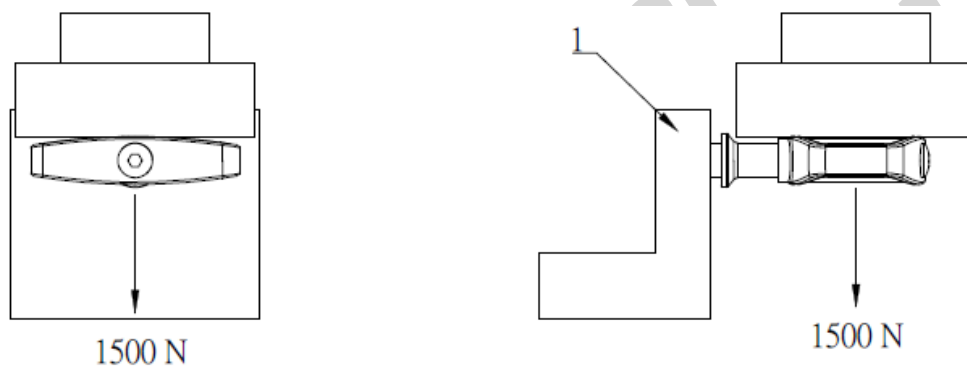

1 Rigid mount

Figure 38 — Pedal/pedal-spindle assembly: static strength test

4.3.12.4 Pedal – Impact test

4.3.12.4.1 Requirement

When tested by the method described in 4.3.12.4.2, there shall be no fractures of any part of the pedal body, the pedal-spindle or any failure of the bearing system.

4.3.12.4.2 Test method

Screw the pedal-spindle securely into a suitable rigid fixture with its axis horizontal as shown in Figure 40 and release a striker of the design shown in Figure 39 and mass 15 kg from a height of 400 mm to strike the pedal at the centre of the pedal. The width of the striker shall be wider than the width of the tread surface.

Dimensions in millimetres

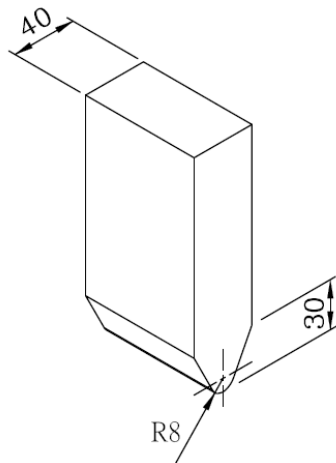

Figure 38 —striker Dimensions

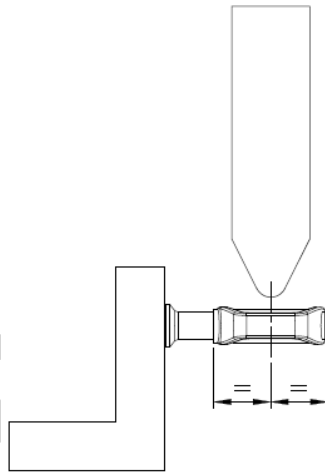

Figure 40 — Position of impact

4.3.12.5 Pedal – Dynamic durability test

4.3.12.5.1 Requirement

When tested by the method described in 4.3.12.5.2, there shall be no fractures or visible cracking of any part of the pedal, the pedal-spindle nor any failure of the bearing system.

4.3.12.5.2 Test method

Pedal — Dynamic durability test could choose one or both of sec.4.3.12.5.2.1 and sec. 4.3.12.5.2.2

4.3.12.5.2.1 Test method (1)

Screw each pedal securely into a threaded hole in a rotatable test-shaft as shown in Figure 41-1 and suspend a mass of M at the centre of the pedal width by means of a tension-spring to each pedal, the object of the springs being to minimize oscillations of the load. The masses are given in Table 28.

Drive the shaft at a speed not exceeding 100 min^{-1} for a total of 100 000 revolutions.

If the pedals are provided with two tread surfaces, they shall be turned through 180° after 50 000 revolutions.

4.3.12.5.2.2 Test method (2)

Screw each pedal securely into a threaded hole in a rotatable test shaft at 30° to the horizontal as shown in Figure 41-2 and suspend a mass of M at the centre of the pedal width by means of a tension spring to each pedal, the object of the springs being to minimize oscillations of the load. The masses are given in Table 28.

Drive the shaft at a speed not exceeding 100 min^{-1} for a total of 100 000 revolutions.

If the pedals are provided with two tread surfaces, they shall be turned through 180° after 50 000 revolutions.

Table 28 — Masses on pedal

Type	city and trekking bicycle	young adult bicycle	mountain-bicycle	racing-bicycle
Mass , kg	80	80	90	90

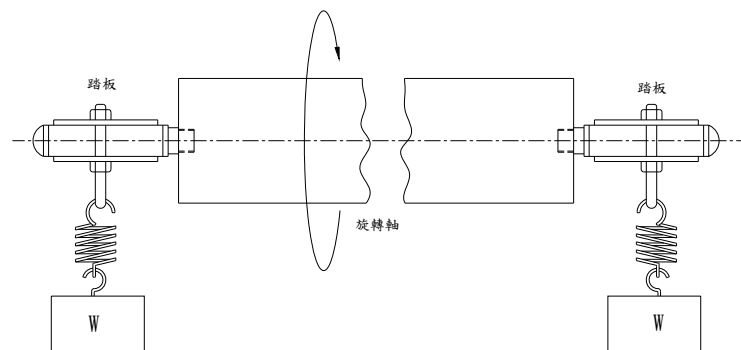
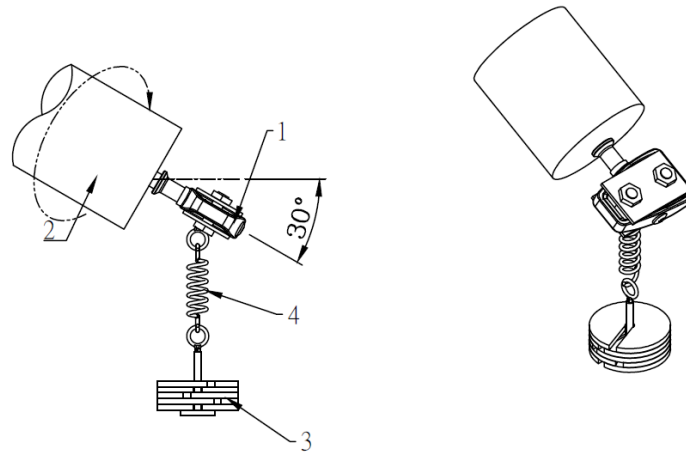

Figure 41-1 — Pedal/pedal-spindle: dynamic durability test



- 1 Pedal
- 2 spindle
- 3 Mass
- 4 Spring

Figure 41-2 — Pedal/pedal-spindle: dynamic durability test

4.3.12.6 Drive-system – Static strength test

4.3.12.6.1 Requirement

a) Drive-system with chain

When tested by the method described in 4.3.12.6.2, there shall be no fracture of any component of the drive system, and drive capability shall not be lost.

b) Drive-system with belt

When tested by the method described in 4.3.12.6.3, there shall be no fracture of any component of the drive.

system, and the belt shall not slip/skip, fracture or cause any loss in drive capability. Smooth sliding between pulleys and belt is allowed at a rate not exceeding 1 °/s at the drive axis.

4.3.12.6.2 Test method for drive-system with chain

4.3.12.6.2.1 General

Conduct the drive system static load test on an assembly comprising the frame, pedals, transmission system, rear wheel assembly, and, if appropriate, the gear-change mechanism. Support the frame with the central plane vertical and with the rear wheel held at the rim to prevent the wheel rotating.

4.3.12.6.2.2 Single-speed system

With the left-hand crank in the forward position, apply a force, F_1 , increasing gradually to 1 500 N vertically downwards to the centre of the left-hand pedal.

Maintain this force for 1 min.

Should the system yield or the drive-sprockets tighten such that the crank rotates while under load to a position more than 30° below the horizontal, remove the test force, return the crank to the horizontal position or some appropriate position above the horizontal to take account of yield or movement and repeat the test.

On completion of the test on the left-hand crank repeat the test with the right-hand crank in the forward position and with the force applied to the right-hand pedal.

4.3.12.6.2.3 Multi-speed system

- a) Conduct the tests described in 4.3.12.6.2.2 with the transmission correctly adjusted in its highest gear;
- b) Conduct the tests generally as described in 4.3.12.6.2.2 with the transmission correctly adjusted in its lowest gear but, where appropriate, with the maximum force, F_1 , adjusted to suit the particular gear ratio, thus:

The maximum force, F_1 , shall be a function of the lowest gear ratio, N_c/N_s ,

Where

F_1 is the force applied to the pedal, expressed in newton, N ;

N_c is the number of teeth on the smallest chain-wheel (front) ;

N_s is the number of teeth on the largest sprocket (rear).

Where the ratio N_c/N_s has a value equal to or greater than one, the force, F_1 , shall be 1 500 N, but where the ratio N_c/N_s has a value less than one, the force, F_1 , shall be reduced in proportion to the lowest gear ratio thus:

$$F_1 = 1500 \times N_c/N_s.$$

4.3.12.6.3 Test method for drive-system with belt

The sample in its fully finished condition (with teeth if any) shall be submitted to a water spray conditioning equivalent to IPX4 specified in EN 60529:1991, 14.2.4, during 10 min. Application of the loading shall be done within 20 min after conditioning.

- a) If the drive-system is a single-speed system, conduct the tests as described in 4.3.12.6.2.2.
- b) If the drive-system is a multi-speed system, conduct the tests as described in 4.3.12.6.2.3.

4.3.12.7 Crank assembly – Fatigue test

4.3.12.7.1 Requirement

4.3.12.7.1.1 Requirement of the cranks positioned at 45° to the horizontal

When tested by the method described in 4.3.12.7.2, there shall be no fractures or visible cracks in the cranks, the bottom-bracket spindle or any of the attachment features, or loosening or detachment of the chain-wheel from the crank.

For composite cranks, the running displacements (peak-to-peak values) of either crank at the point where the test forces are applied shall not increase by more than 20 % of the initial value (see 4.3.1.6).

4.3.12.7.1.2 Requirement of the cranks positioned at 30° to the horizontal (Special requirements for mountain bicycles)

For mountain bicycles, two types of fatigue test are specified, one with the cranks positioned at 45° to the horizontal to simulate the forces due to pedalling, and the second test with the cranks positioned at 30° to the horizontal, which has been found to simulate the forces due to the rider standing on the pedals during the descent of hills. The two tests shall be conducted on separate assemblies.

When tested by the method described in 4.3.12.7.3, there shall be no fractures or visible cracks in the cranks, the bottom-bracket spindle or any of the attachment features, or loosening or detachment of the chain wheel from the crank.

For composite cranks, the running displacements (peak-to-peak values) of either crank at the point where the test forces are applied shall not increase by more than 20 % of the initial value.

4.3.12.7.2 Test method with the cranks positioned at 45° to the horizontal

Mount the assembly of the two pedal-spindle adaptors, the two cranks, the chain-wheel set (or other drive component), and the bottom-bracket spindle located on its normal-production bearings in a fixture with bearing housings representative of the bottom-bracket (as shown in Figure 42a). Incline the cranks at 45° to the horizontal.

Prevent rotation by locating a suitable length of drive chain around the largest or only chain-wheel and securing it firmly to a suitable support, or, for any other type of transmission (e.g. belt-or shaft-drive) by securing the first stage of the transmission.

NOTE It is permissible to have the left crank in either of the two positions shown in Figure 42a, provided the test force is applied in the appropriate direction as specified in the next paragraph.

4.3.12.7.2.1 Stage 1 Test method with the cranks positioned at 45° to the horizontal

Apply repeated, vertical, dynamic forces of F_2 alternately to the pedal-spindle adaptors of the left-and right-hand cranks at a distance of 65 mm from the outboard face of each crank (as shown in Table 29 and Figure 42a) for C test cycles (where one test cycle consists of the application of the two forces). The direction of the force on the right-hand crank shall be downwards and that on the left-hand crank shall be upwards for a rearward-pointing crank or downwards for a forward-pointing crank. During application of these test forces, ensure that the force on a pedal-spindle adaptor falls to 5 % or less of the peak force before commencing application of the test force to the other pedal-spindle adaptor. The maximum test frequency shall be maintained as specified in 4.3.1.5.

4.3.12.7.2.2 Stage 2 Test method with the cranks positioned at 45° to the horizontal

Apply repeated, vertical, dynamic forces of stage 2 F_2 alternately to the pedal-spindle adaptors of the drive side and non-drive side crank at a distance of 65 mm from the outboard face of each crank (as shown in Table 29 and Figure 42a) for C test cycles (where one test cycle consists of the application of the two forces). The direction of the force on the drive side crank shall be downwards and that on the non-drive side crank shall be upwards for a rearward-pointing crank, or downwards for a forward-pointing crank. During application of these test forces, ensure that the force on a pedal-spindle adaptor falls to 5 % or less of the peak force before commencing application of the test force to the other pedal-spindle adaptor. The maximum test frequency shall be maintained as specified in sec.4.3.1.5.

Table 29 Force and cycles

Type	city and trekking bicycle	young adult bicycle	mountain-bicycle	racing-bicycle
Stage 1 Force F_2 , N	1300	1300	1800	1800
Stage 2 Force F_2 , N	1400	1400	1900	1900
Stage 1 Test cycles , C	120 000	120 000	60 000	120 000
Stage 2 Test cycles , C	100 000	100 000	50 000	100 000

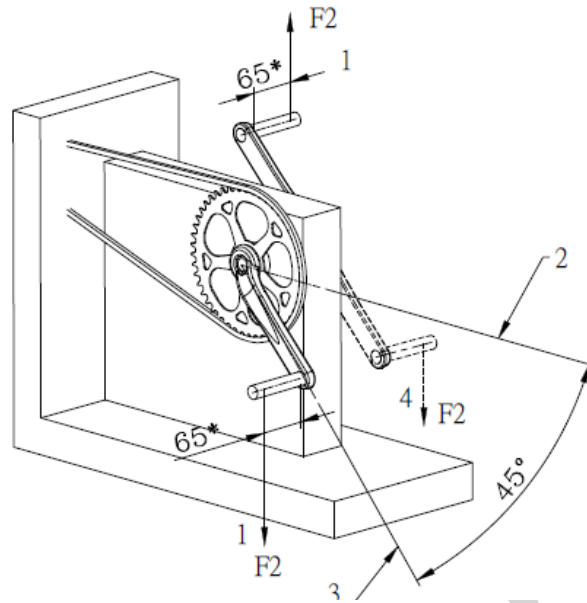

- 1 Repeated test force
- 2 Horizontal axis
- 3 Axis of crank
- 4 Alternative left crank arrangement
- 5 From outboard face of crank

Figure 42a — Crank assembly — the cranks positioned at 45° to the horizontal

4.3.12.7.3 Test method with the cranks at 30° to the horizontal for mountain bicycles

Mount the assembly of the two pedal-spindle adaptors, the drive side and non-drive side crank, the chain wheel set (or other drive component), and the bottom-bracket spindle located on its normal-production bearings in a fixture with bearing housings representative of the bottom-bracket, as shown in Figure 42b. Incline the cranks at 30° to the horizontal. Restrain the non-drive side crank to the base of the test machine by a device attached to the pedal-spindle at a distance of 65 mm from the outboard face of the crank.

4.3.12.7.3.1 Stage 1 Test method with the cranks at 30° to the horizontal

Apply a repeated, vertically downward, dynamic force of 1 800 N to the pedal-spindle of the drive side crank at a distance of 65 mm from the outboard face of the crank (as shown in Figure 42b) for 60 000 cycles. The maximum test frequency shall be maintained as specified in 4.3.1.5.

4.3.12.7.3.2 Stage 2 Test method with the cranks at 30° to the horizontal

Apply a repeated, vertically downward, dynamic force of 1 900 N to the pedal-spindle of the drive side crank at a distance of 65 mm from the outboard face of the crank (as shown in Figure 42b) for 50 000 cycles. The maximum test frequency shall be maintained as specified in 4.3.1.5.

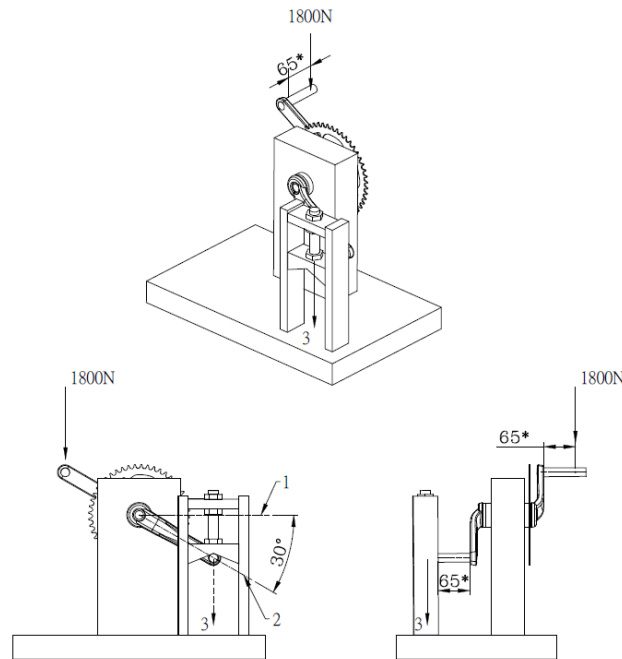

- 1 Horizontal axis
- 2 Axis of crank
- 3 Alternative left crank arrangement

Figure 42b—Crank assembly—the cranks at 30° to the horizontal

4.3.13 Drive-chain and drive belt

4.3.13.1 Drive-chain

Where a chain-drive is used as a means of transmitting the motive force, the chain shall operate over the front and rear sprockets without binding.

The chain shall conform to the tensile strength and push-out force requirements of ISO 9633. But the tension strength of racing bike should higher than 9000 N, and record the yield point and Max. strength value and push-out force during the test.

4.3.13.2 Drive belt

4.3.13.2.1 Requirement

Where a belt-drive is used as a means of transmitting the motive force, the drive belt shall operate over the front and rear pulleys without binding. And when tested by the methods described in 4.3.13.2.2, there shall be no evidence of cracking, fracture or delamination of the belt drive.

4.3.13.2.2 Test method

Set up a fixture with two drive pulleys that are similar or identical as shown in Figure 43. At least one pulley should be free to rotate. Increase the tensile load gradually until the tension load of the belt reaches 4 000 N.

NOTE 4 000 N is the tension load within the belt and requires a load F of 8 000 N to achieve this tension load.

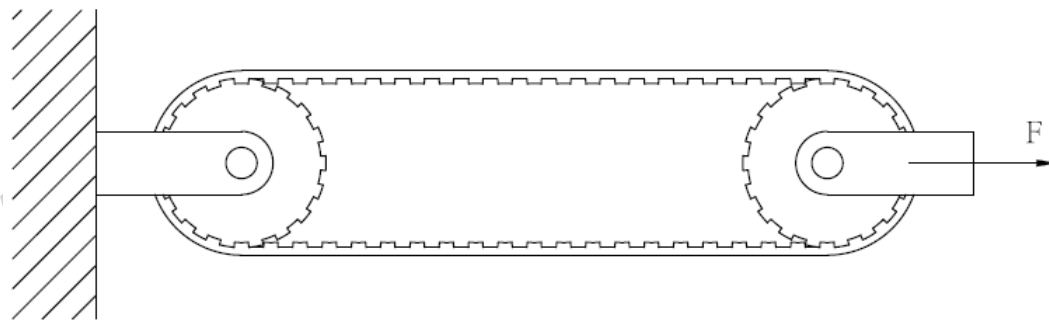

Figure 43 — Drive belt – Tensile strength test

4.3.14 Chain-wheel and belt-drive protective device

4.3.14.1 Requirement

EPAC shall be equipped with one of the following;

- a) a chain wheel disc or drive pulley disk which conforms to 4.3.14.2; or
- b) a chain and drive belt protective device which conforms to 4.3.14.3; or
- c) where fitted with positive foot-retention devices on the pedals, a combined front gear-change guide which conforms to 4.3.14.4 shall be used.

4.3.14.2 Chain-wheel disc and drive pulley disc diameter

A chain-wheel disc shall exceed the diameter of the outer chain-wheel, when measured across the tips of the teeth by not less than 10 mm (see Figure 44).

A drive pulley disc shall exceed the diameter of the front pulley, when measured across the tips of the teeth by not less than 10 mm (see Figure 45). Where the design is such that the pedal-crank and chain-wheel are too close together to accommodate a full disc, a partial disc may be fitted which closely abuts the pedal-crank.

Dimensions in millimetres

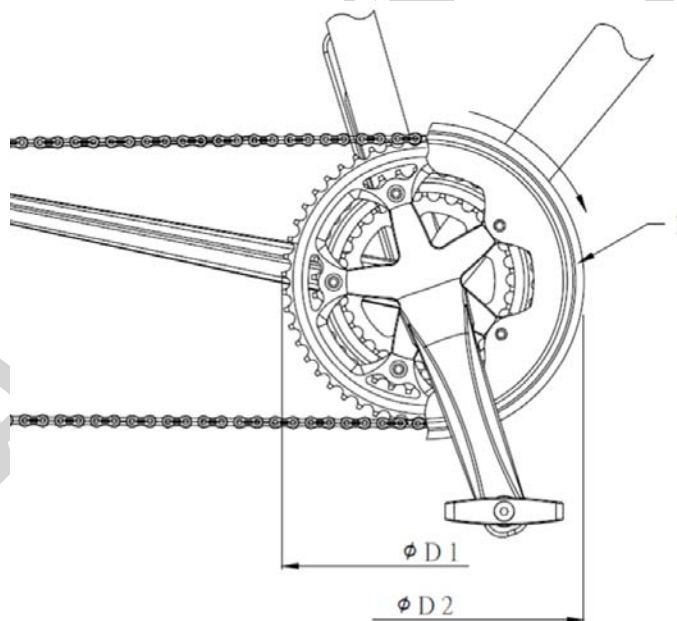

1 Chain-wheel disc $D2 \geq D1 + 10$

Figure 44 — Chain-wheel disc

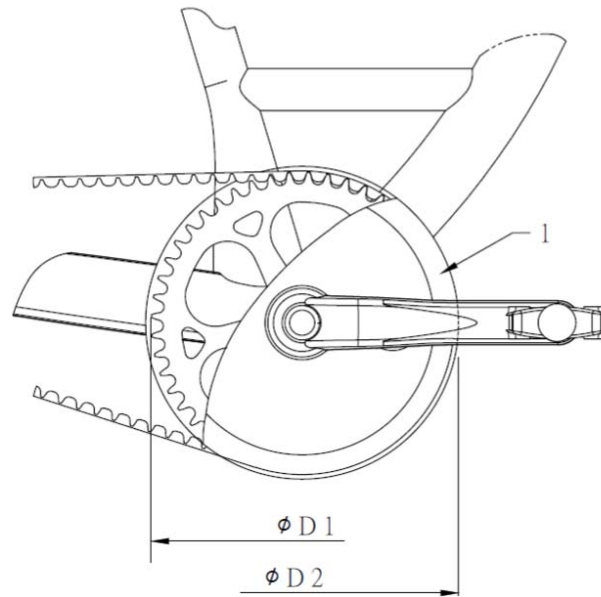

1 Drive pulley disc $D2 \geq D1 + 10$

Figure 45 — Drive pulley disc

4.3.14.3 Chain and drive belt protective device

A chain protective device shall, as a minimum, shield the side-plates and top surface of the chain and the chain-wheel for a distance of at least 25 mm rearwards along the chain from the point where the chain-wheel teeth first pass between the side-plates of the chain and forwards round the outer chain-wheel to a horizontal line passing through the bottom-bracket axle centre (see Figure 46 a)).

A drive belt protective device shall, as a minimum, shield the side and top surface of the drive belt and the front pulley for a distance of at least 25 mm rearwards along the drive belt from the point where the tip circle of the pulley is intersected by the tip line of the belt (line C in Figure 46 b)) and forwards round the front pulley to a horizontal line passing through the bottom-bracket axle centre (see Figure 46 b)).

Dimensions in millimetres

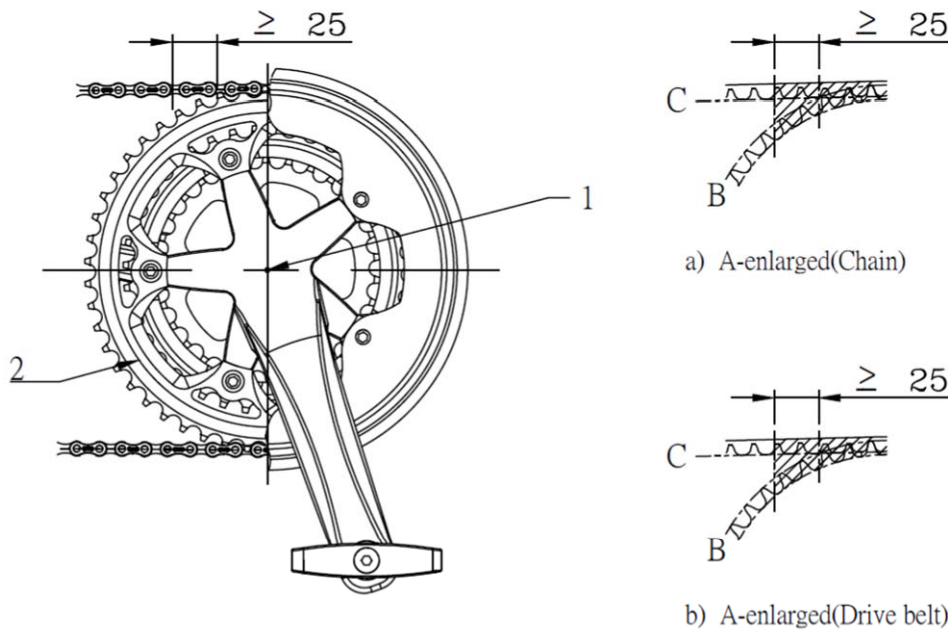

1 Bottom-bracket axle centre

2 Chain-wheel or front pulley

Figure 46 — Chain and drive belt protective device requirements (minimum)**4.3.14.4 Combined front gear-change guide**

When the chain is located in the outer gear position, some portion of the combined front gear change guide shall be above the chain in the region 25 mm from the point where the chain wheel first passes between the side plates of the chain, parallel to the chain side plates in the direction towards the rear wheel of the bicycle (see Figure 47).

In addition some portion of the combined front gear change guide shall be present below the chain in the region beyond 25 mm from the point where the chain wheel first passes between the side plates of the chain, parallel to the chain side plates in the direction towards the rear wheel of the bicycle (see Figure 47).

It is recommended that the gap between front-gear and front gear-change guide specified by the manufacturer is properly set.

Dimensions in millimetres

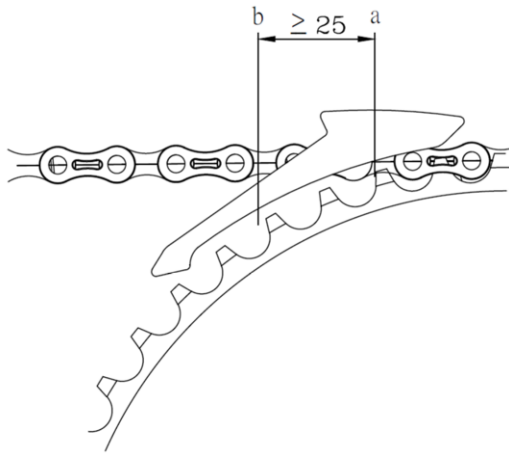

- a the point where the chain-wheel first passes between the side-plates of the chain.
- b 25 mm rearwards from the point where the chain-wheel first passes between the side plates of the chain.

Figure 47 — Chain and chain-wheel junction

All rights reserved
Reprints must investigate

4.3.15 Saddles and seat-posts

4.3.15.1 Limiting dimensions

No part of the saddle, saddle supports, or accessories to the saddle shall be more than 125 mm above the top saddle surface at the point where the saddle surface is intersected by the seat-post axis.

4.3.15.2 Seat-post – Insertion-depth mark or positive stop

The seat-post shall be provided with one of the two following alternative means of ensuring a safe insertion-depth into the frame:

- a) it shall contain a permanent, transverse mark of length not less than the external diameter or the major dimension of the cross-section of the seat-post that clearly indicates the minimum insertion-depth of the seat-post into the frame. For a circular cross-section, the mark shall be located not less than two diameters of the seat-post from the bottom of the seat-post (i.e. where the diameter is the external diameter). For a non-circular cross-section, the insertion-depth mark shall be located not less than 65 mm from the bottom of the seat-post (i.e. where seat-post has its full cross-section);
- b) it shall incorporate a permanent stop to prevent it from being drawn out of the frame such as to leave the insertion less than the amount specified in a) above.

4.3.15.3 Saddle/seat-post – security test

4.3.15.3.1 General

If a suspension seat-post is involved, the test may be conducted with the suspension-system either free to operate or locked. If it is locked, the pillar shall be at its maximum length.

4.3.15.3.2 Saddles with adjustment-clamps

When tested by the method described in 4.3.15.3.4, there shall be no movement of the saddle adjustment clamp in any direction with respect to the seat-post, or of the seat-post with respect to the frame, nor any failure of saddle, adjustment clamp or seat-post. If the saddle design is such that it cannot accurately test the saddle/seat-post clamp, it shall be possible to use a fixture which is representative of the saddle dimensions.

4.3.15.3.3 Saddles without adjustment-clamps

Saddles that are not clamped, but are designed to pivot in a vertical plane with respect to the seat-post, shall be allowed to move within the parameters of the design and shall withstand the tests described in 4.3.15.3.4 without failure of any components.

4.3.15.3.4 Test method

With the seat-post correctly assembled to EPAC frame at minimum insertion depth of the seat-post, and the clamps tightened to the torque recommended by the bicycle manufacturer, apply a force of F_1 vertically downwards at a point 25 mm from either the front or rear of the saddle, whichever produces the greater torque on the saddle-clamp. The saddle shall be positioned in the seat post clamp assembly as defined by the saddle manufacturer’s rail markings or instructions. Maintain this force for 1 min. Remove this force and apply a lateral force of F_2 horizontally at a point 25 mm from either the front or rear of the saddle and maintain this force for 1 min, whichever produces the greater torque on the clamp (see Figure 48). The forces are given in Table 31.

The fixture shall be such that it does not damage the surface of the saddle.

Table 31 — Forces on saddle

Type	Force in N			
	city and trekking bicycle	young adult bicycle	mountain-bicycle	racing-bicycle
Vertical force, F_1	1000			
Horizontal force, F_2	450			

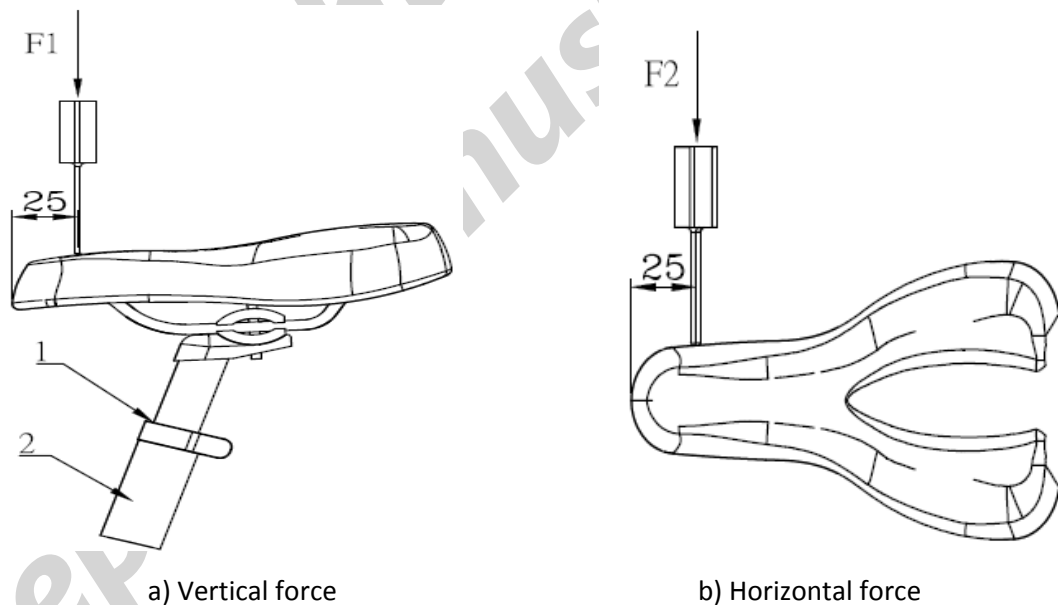

- 1 Minimum insertion-depth mark
- 2 Bicycle frame

Figure 48 — Saddle/seat-post: security test

4.3.15.4 Saddle – Static strength test

4.3.15.4.1 Requirement

When tested by the method described in 4.3.15.4.2, the saddle cover and/or plastic moulding shall not disengage from the chassis of the saddle, and there shall be no cracking or permanent.

4.3.15.4.2 Test method

With the saddle positioned in a suitable fixture representative of a seat-post clamp assembly and in a maximum rearward direction as defined by the saddle manufacturer's rail markings or instructions, and the clamps tightened to the torque recommended by the bicycle manufacturer, apply forces F_{20} of 440 N in turn under the rear and nose of the saddle cover, as shown in Figure 49, ensuring that the force is not applied to any part of the chassis of the saddle. The load application point is on the longitudinal plane of the saddle at 25 mm from the back (/front) of the saddle. If the saddle design is such that it cannot accept a centreline load application, the load shall be symmetrically applied at two points of the saddle.

NOTE Loading on the rear of the saddle is required to be symmetrical about its longitudinal axis, as shown in Figure 50.

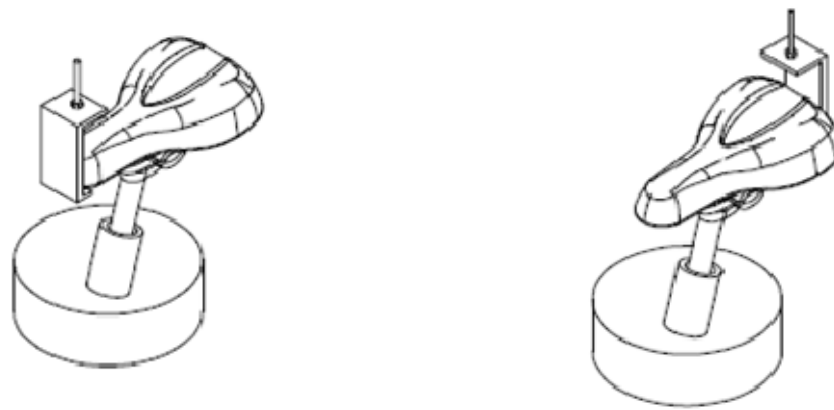

a) Force under nose

b) Force under rear

Figure 49 — Saddle: static strength test

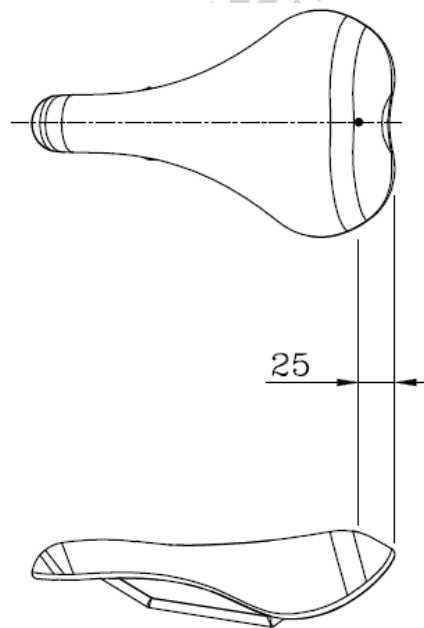

1 Loading point

Figure 50 — Saddle: load application point of static strength test

4.3.15.5 Saddle and seat-post clamp – Fatigue test

4.3.15.5.1 General

Seat-posts can influence test failures of saddles: for this reason, a saddle shall be tested in combination with a seat-post as recommended by the saddle manufacturer.

4.3.15.5.2 Requirement

When tested by method described in 4.3.15.5.3, there shall be no fractures or visible cracks in the seat-post or in the saddle, and no loosening of the clamp.

4.3.15.5.3 Test method

Insert the seat-post to its minimum insertion depth in a rigid mount representative of that on the bicycle and with its axis at 73° to the horizontal. The saddle shall be positioned in the seat post clamp assembly in a maximum rearward direction as defined by the saddle manufacturer's rail markings or instructions. Adjust the saddle to have its upper surface in a horizontal plane and tighten the clamp to the torque recommended by the bicycle manufacturer. Apply a repeated, vertically-downward force of 1 000 N for 200 000 cycles, in the position shown in Figure 51 by means of a pad 300 mm long x 80 mm diameter to prevent localized damage of the saddle cover. The maximum test frequency shall be maintained as specified in 4.3.1.5.

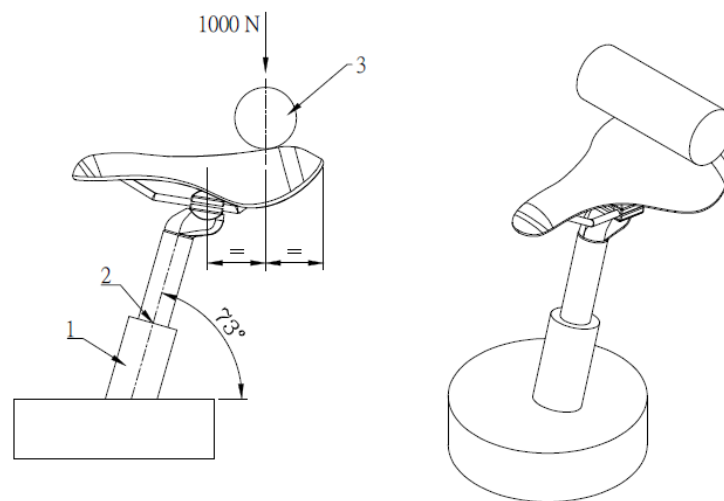

- 1 Rigid mount
- 2 Minimum insertion-depth mark
- 3 Pad (length = 300 mm, diameter = 80 mm)

Figure 51 — Saddle and seat-post clamp – Fatigue test

4.3.15.6 Seat-post – Fatigue test

4.3.15.6.1 General

In the following test, if a suspension seat-post is involved, the test shall be conducted with the suspension system adjusted to give maximum resistance.

Conduct the test in two stages on the same assembly as per 4.3.15.6.2 and 4.3.15.6.4.

4.3.15.6.2 Requirement for stage 1

4.3.15.6.2.1 Seat-post without suspension system

When tested by the method described in 4.3.15.6.3, there shall be no visible cracks or fractures in the seat-post, nor any bolt failure.

For composite seat-post, the peak deflection of seat-post during the test shall not increase by more than 20 % of the initial value.

4.3.15.6.2.2 Seat-post with suspension system

When tested by the method described in 4.3.15.6.3, there shall be no visible cracks or fractures in the seat-post, nor any bolt failure. The design shall be such that in the event of failure of the suspension system, the two main parts do not separate nor does the upper part (i.e. the part to which the saddle would be attached) become free to swivel in the lower part.

4.3.15.6.3 Test method for stage 1 (fatigue test)

4.3.15.6.3.1 Test method for stage 1-1 (fatigue test)

A seat post shall be inserted to the minimum insertion depth in a suitable fixture with a representative seat collar and clamped to the manufacturers recommended torque. The seat post shall be fixed at an angle of 73° from horizontal, as shown in Figure 52.

Secure an extension-bar to the saddle attachment point by the appropriate attachment fitting such that the bar extends rearwards and downwards at an angle of 10° below the horizontal to permit the application of a vertical test force at a distance of 70 mm from the centre of the saddle-clamp where the centre-line of the clamp intersects the axis of the bar, as shown in Figure 52.

Apply a repeated, vertically downward, dynamic force of F_3 to the point described above and shown in Figure 52 for 120 000 cycles. The forces are given in Table 32. The maximum test frequency shall be maintained as specified in 4.3.1.5.

4.3.15.6.3.2 Test method for stage 1-2 (fatigue test)

Apply a repeated, vertically downward, dynamic force of stage 1-2 F_3 to the point described above and shown in Figure 52 for 100 000 cycles. The forces are given in Table 32. The maximum test frequency shall be maintained as specified in Sec. 4.3.1.5.

Table 32 — Forces on seat-post

Type	Force in N			
	city and trekking bicycle	young adult bicycle	mountain-bicycle	racing-bicycle
stage 1-1 Force, F_3	1000	1000	1200	1200
stage 1-2 Force, F_3	1100	1100	1300	1300

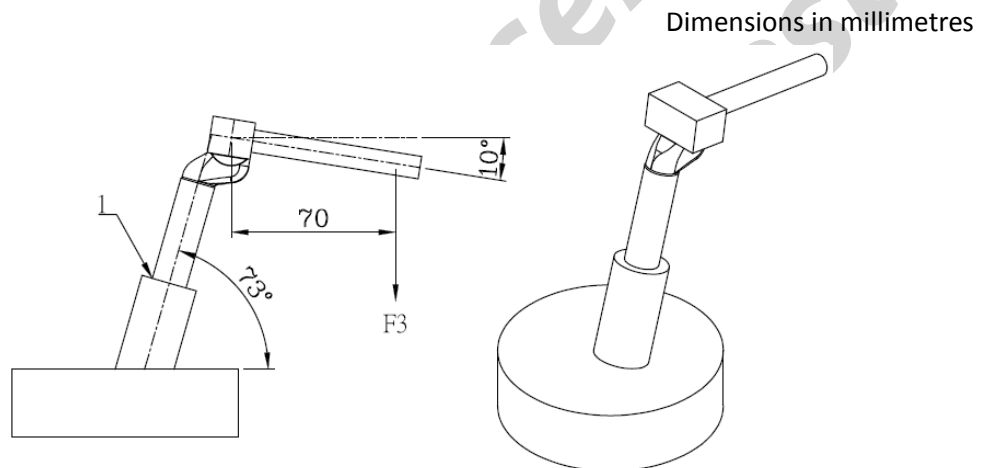

1 Minimum insertion-depth mark

Figure 51 — Seat-post – Fatigue test

4.3.15.6.4 Requirement for stage 2

4.3.15.6.4.1 Seat-post without suspension system

When tested by the method described in 4.3.15.6.5, there shall be no fractures, and the displacement shall not exceed 10 mm during testing.

4.3.15.6.4.2 Seat-post with suspension system

When tested by the method described in 4.3.15.6.5, there shall be no fractures. The design shall be such that in the event of failure of the suspension system, the two main parts do not separate nor does the upper part (i.e. the part to which the saddle would be attached) become free to swivel in the lower part.

4.3.15.6.5 Test method for stage 2 (static strength test)

A seat post shall be inserted to the minimum insertion depth in a suitable fixture with a representative seat collar and clamped to the manufacturers recommended torque. The seat post shall be fixed at an angle of 73° from horizontal, as shown in Figure 53.

A force of F_4 shall be exerted vertically on the saddle clamp for duration of 1 min. The displacement at the loading point shall be constantly monitored during testing. The forces are given in Table 33.

Table 33 — Forces on seat-post

Force in N	
Force, F_4	2000

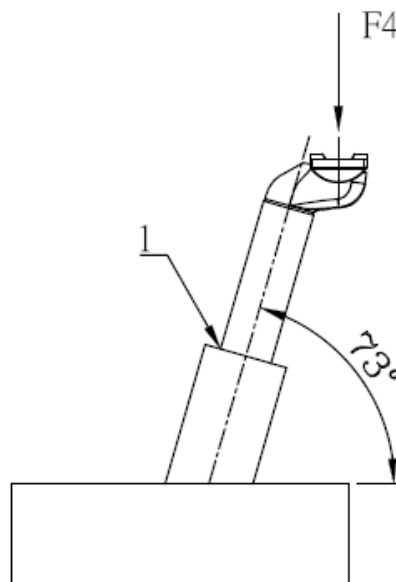

1 Minimum insertion-depth mark

Figure 53 — Seat-post: static strength test

4.3.16 Spoke protector

EPAC bicycles with multiple free-wheel/cassette sprockets shall be fitted with a spoke-protector guard to prevent the chain interfering with or stopping rotation of the wheel through improper adjustment or damage.

4.3.17 Luggage carriers

If luggage carriers are fitted or provided, they shall comply with EN 14872, if the luggage carrier is design for the battery carrier, the loading condition should add the weight of battery.

4.3.18 Road-test of a fully-assembled EPAC

4.3.18.1 Requirements

When tested by the method described in 4.3.18.2, there shall be no system or component failure and no loosening or misalignment of the saddle, handlebar, controls or reflectors.

The EPAC shall with or without assistance exhibit stable handling in braking, turning and steering, and it shall be possible to ride with one hand removed from the handlebar (as when giving hand signals), without difficulty of operation or hazard to the rider.

4.3.18.2 Test method

First, check and adjust, if necessary, each EPAC selected for the road test to ensure that the steering and wheels rotate freely without slackness, that brakes are correctly adjusted and do not impede wheel rotation. Check and adjust wheel alignment and, if necessary, inflate tyres to the recommended pressure as marked on the side-wall of the tyre. Check and correct, if necessary, transmission-chain adjustment, and check any gear-control fitted for correct and free operation.

Carefully adjust the saddle and handlebar positions to suit the rider.

The test shall be carried out with the permissible total weight specified by the manufacturer in 6 n). Ensure that the EPAC is ridden for at least 1km.

4.3.19 Lighting systems and reflectors

4.3.19.1 General

EPAC shall be equipped with reflectors at the front, rear and side. EPAC shall be equipped with lighting systems and reflectors in conformity with the national regulations in the country in which EPAC is marketed, because national regulations for lighting systems and reflectors differ from country to country.

4.3.19.2 Wiring harness

When a wiring harness is fitted, it shall be positioned to avoid any damage by contact with moving parts or sharp edges. All connections shall withstand a tensile force in any direction of 10 N.

4.3.19.3 Lighting systems

The lighting system consists of a front and a rear light. These devices shall comply with the provisions in force in the country in which the product is marketed. If there are no forced provisions of these devices, the lighting system shall comply with the requirements of ISO 6742-1.

4.3.19.4 Reflectors

4.3.19.4.1 General

These devices shall comply with the provisions in force in the country in which the product is marketed. If there are no forced provisions of these devices, the retro-reflective devices shall comply with the requirements of ISO 6742-2.

4.3.19.4.2 Rear reflectors

Rear reflectors shall be red in colour.

4.3.19.4.3 Side reflectors

The retro reflective device(s) shall be either

- a) a reflectors fitted on the front half and on the rear half of EPAC. At least one of these shall be mounted on the spokes of the wheel. Where EPAC incorporates features at the rear wheel other than the frame and mudguard stays, the moving reflector shall be mounted on the front wheel; or
- b) a continuous circle of reflective material applied to both sides of each wheel within 10 cm of the outer diameter of the tyre.

All side reflectors shall be of the same colour, either white (clear) or yellow.

4.3.19.4.4 Front reflectors

Front reflectors shall be white (clear) in colour.

4.3.19.4.5 Pedal reflectors

Each pedal shall have reflectors, located on the front and rear surfaces of the pedal. The reflector elements shall be either integral with the construction of the pedal or mechanically attached, but shall be recessed from the edge of the pedal, or of the reflector housing, to prevent contact of the reflector element with a flat edge placed in contact with the edge of the pedal. Pedal reflectors shall be yellow in colour.

4.3.20 Warning device

Where a bell or other suitable device is fitted, it shall comply with the provisions in force in the country in which the product is marketed.

4.3.21 Thermal hazards

A warning shall be placed on the surface if the temperature of the hot accessible surface could be above 60°C (see EN ISO 7010:2012, symbol W017). Brake systems are excluded from this requirement.

4.3.22 Performance levels (PLrs) for control system of EPACs

The safety related parts of the control systems of the EPAC shall comply with the required performance level (PLr) given in Table 34 in accordance with EN ISO 13849-1.

Should risk assessment indicate that additional or different PLr are required for a particular application, these should be determined in accordance with EN ISO 13849 (all parts). Such PLr will be outside the scope of this standard.

The manufacturer of the EPAC shall record the process adopted for verification of compliance with PLr for each relevant safety function.

Table 34 — Safety functions related to defined hazards

Safety function	Performance Level
Prevention of an unintentional self-start of the EPAC	PLr c
Prevention of electric motor assistance functions without pedalling, and without activation of the start-up assistance mode	PLr c
Prevention of risk of fire in case of management system failure for batteries with capacity above 100 Wh	PLr c

4.4 List of significant hazards

4.4.1 Significant hazards

The following significant hazards have been considered in this standard:

NOTE 1 The risk analysis was focused on EPAC as bicycles for city and trekking, including folding bicycles.

Mountain bike and racing bike were not considered.

a) Mechanical hazards: high deceleration, high acceleration, Protrusion, instability; kinetic energy; rotating elements and moving elements, rough, slippery surface, sharp edges;

b) Electrical hazards: electromagnetic phenomena; electrostatic phenomena; overload; short-circuit; thermal radiation;

NOTE 2 The strength of the battery holder combination should the EPAC fall to the side will be considered at the next revision.

c) Thermal hazards: explosion; flame; radiation from heat sources;

d) Ergonomic hazards: effort; lighting; posture;

e) Hazards associated with the environment in which the machine is used: water (rain and projection);

f) Combination of hazards: braking under wet and dry condition, handgrips, motor management system, engine power management, installed braking power.

All rights reserved
Reprints must investigate

5 Marking, labelling

5.1 Requirement

The EPAC shall be marked visibly, legibly and indelibly with the following minimum particulars:

- Contact and address of the manufacturer or authorized representative;
- EPAC according to TBIS 15194;
- Appropriate marking ;
- Year of construction, that is the year in which the manufacturing was completed (it is not possible to use a code);
- Cut off speed XX km/h;
- Maximum continuous rated power XX kW;
- Maximum permissible total weight (e.g. marked near the seat post or handlebar);
- Designation of series or type;
- Individual serial number if any;
- Mass of the EPAC in the most usual configuration.

The frame shall be:

- a) visibly and permanently marked with a successive frame number at a readily visible location such as near the pedal-crank, the seat-post, or the handlebar;
- b) visibly and durably marked, with the name of the manufacturer of complete EPAC or the manufacturer's representative and the number of this document, i.e. EN 15194. The method of testing for durability is specified in 5.2.

Where appropriate, if EPAC is equipped with a coupling device for a trailer the following values shall be given:

- c) Total weight of the trailer
- d) Vertical load on the coupling system.

NOTE In some countries there is a legal requirement concerning marking of bicycles.

For components, currently there are no specific requirements, but it is recommended that the following safety-critical components be clearly and permanently marked with traceable identification, such as a manufacturer's name and a part number:

- e) front fork;
- f) handlebar and handlebar-stem;
- g) seat-post;
- h) brake-levers, brake blocks and/or brake-block holders;
- i) outer brake-cable casing;

- j) hydraulic-brake tubing;
- k) disc-brake callipers, brake-discs, and brake pads;
- l) chain;
- m) pedals and cranks;
- n) bottom-bracket spindle;
- o) wheel-rims.

5.2 Marking test

5.2.1 Marking Durability test

5.2.1.1 Requirement

When tested by the method described in 5.2.1.2, the marking shall remain easily legible. It shall not be easily possible to remove any label nor shall any label show any sign of curling.

5.2.1.2 Test method

Rub the marking by hand for 15 s with a piece of cloth soaked in water and again for 15 s with a piece of cloth soaked in petroleum spirit.

5.2.2 Marking Safety requirement

Component of the paint should meet the requirements of RoHS.

6 Instruction for use

Each EPAC shall be provided with a set of instructions in the language of the country to which EPAC will be supplied. Different countries may have local requirements regarding this type of information(see EN 82079-1). Instructions for use shall be delivered obligatory in paper form. For more detailed information and enabling an access for vulnerable people instructions for use should be available additionally in electronic form on demand. Instructions for use shall contain the following information on:

- a) Concept and description of electric assistance including varying levels of motor assistance;
- b) Recommendation for cleaning and the use of high pressure cleaners;
- c) Control and tell tales;
- d) Specific EPAC recommendation for use (e.g. removal of the battery, temperature range for the use of the bicycle including battery, use of start-up assistance mode);
- e) Specific EPAC warnings (e.g. always remove the battery during maintenance, inappropriate use including manipulation of the electric management system);
- f) Recommendations about battery charging and charger use (e.g. temperature range for the battery storage, indoor or outdoor charging) as well as the importance of following the instruction contained on the label of the battery charger.
- g) The meaning of symbol and tell tales used shall be explained in the instruction for use. Warning about contact with hot surfaces as for example disc brakes after heavy use.
- h) The type of use for which EPAC has been designed (i.e. the type of terrain for which it is suitable) with a warning about the hazards of incorrect use;

- i) Preparation for riding - how to measure and adjust the saddle height to suit the rider with an explanation of the insertion-depth warning marks on the seat-post and handlebar-stem. Clear information on which lever operates the front brake, which lever operates the rear brake, the presence of any brake-power modulators with an explanation of their function and adjustment, and the correct method of using a back-pedal brake if fitted;
- j) Indication of minimum saddle height and the way to measure it;
- k) The recommended method for adjusting any adjustable suspension system fitted;
- l) Recommendations for safe riding, the use of a bicycle helmet, regular checks on brakes, tyre pressure, steering, rims and caution concerning possible increased braking distances in wet weather;
- m) The safe use and adjustment of foot-securing devices if fitted (i.e. quick-release pedals and toe-clips);
- n) The permissible total weight of the rider plus luggage and the maximum total weight (EPAC + rider + luggage);
- o) Recommendation about usage for bicycle trailer or trailer bicycle if allowed by EPAC manufacturer;
- p) An advisory note to draw attention to the rider concerning possible national legal requirements when EPAC is to be ridden on public roads (e.g. lighting and reflectors);
- q) Recommended tightening of fasteners related to the handlebar, handlebar-stem, saddle, seat-post, wheels, and aerodynamic extension if fitted with torque values for threaded fasteners;
- r) The method for determining the correct adjustment of quick-release devices, such as "the mechanism should emboss the fork-ends when closed to the locked position";
- s) The correct method of assembling any parts supplied unassembled;
- t) Lubrication -where and how often to lubricate, and the recommended lubricants;
- u) The correct chain tension and how to adjust it (if appropriate);
- v) Adjustments of gears and their operation (if appropriate);
- w) Adjustment of brakes and recommendations for the replacement of the friction components;
- x) Recommendations on general maintenance;
- y) The importance of using only genuine replacement parts for safety-critical

- components;
- z) Care of the wheel-rims and a clear explanation of any danger of rim-wear (see also 4.3.10.4 and 5.1); For composite rims wear damage may be invisible to the user, the manufacturer shall explain the consequences of rim wear and how the cyclist can assess the degree of wear or should recommend returning the composite rim to the manufacturer for inspection.
 - aa) The correct gluing technique for wheels equipped with tubular tyres if fitted;
 - bb) Appropriate spares, i.e. tyres, tubes, and brake friction-components;
 - cc) Accessories -where these are offered as fitted, details should be included such as operation, maintenance required (if any) and any relevant spares (e.g. light bulbs);
 - dd) An advisory note to draw attention of the rider to possible damage due to intensive use and to recommend periodic inspections of the frame, fork, suspensions joints (if any), and composite components (if any). The wording of the advice may be as follows;
WARNING 1— As with all mechanical components, EPAC is subjected to wear and high stresses. Different materials and components may react to wear or stress fatigue in different ways. If the design life of a component has been exceeded, it may suddenly fail, possibly causing injuries to the rider. Any form of crack, scratches or change of colouring in highly stressed areas indicate that the life of the component has been reached and it should be replaced.
 - WARNING 2 — For composite components impact damage may be invisible to the user, the manufacturer shall explain the consequences of impact damage and that in the event of an impact; composite components should either be returned to the manufacturer for inspection or destroyed and replaced.**
 - ee) For composite components, an advisory note to draw attention to the influence of high temperature (heat radiations) in confined environment on composite materials (if appropriate);
 - ff) The importance of possible suitably covering any coil springs under the saddle if a child-seat is fitted to prevent trapping of fingers;
 - gg) The handlebar, the rider's response to steering and braking can be adversely affected;

-
- hh) The maximum inflation pressure for a conventional or tubular tyre, according to the lowest value between maximum inflation pressure recommended on the rim or the tyre (see also 4.3.10.2);
 - ii) Recommendation on the installation of bicycle carriers as well as child seats (max. load, mounting, etc.).
- It is permitted to include any other relevant information at the discretion of the manufacturer.
- jj) Definition of tampering in user manual (i.e. exclude exchange of sprocket with non-original parts);
 - kk) Recommendations and users responsibility in case of tampering;
 - ll) The following statement: The A-weighted emission sound pressure level at the driver ears is less than 70 dB(A).

All rights reserved
Reprints must investigate

Annex A
(informative)

Example of recommendation for battery charging

Safety and quality of battery charging can be greatly improved by sensing the battery temperature during charging.

Most battery charger manufacturers set their chargers to have an optimal ambient temperature of 20 °C to 25 °C. Lower temperatures result in under charge, higher temperatures result in over charge.

While it is normal when building battery packs from Ni-Cad, Ni-Mh and Li-ion battery cells, to include temperature sensing, this is not always the case with valve regulated lead acid (VRLA) batteries.

The main reason for including temperature sensing in VRLA batteries is to protect against one or more cells within the battery pack becoming short circuited. This lowers the terminal voltage and can allow the charger to supply more power than is required, which can lead to a dangerous thermal situation.

Temperature sensors should be fitted to each battery within the pack and this information fed back to the battery charger.

It is recommended that positive temperature coefficient (PTC) thermistors are used. All thermistors should be connected in series between the charger temperature pin (T) and the battery pack negative pin (-). Should any battery or cells within the pack reach the temperature given by the battery manufacturer (e.g. 60 °C, 70 °C...) the charger thermal detection circuitry should be adjusted to detect this condition and take suitable measures to stop any further increase in temperature.

Annex B
(informative)
Example of relation between speed/torque/current

This annex gives one example of relation between speed/torque/current with progressively reduced output.

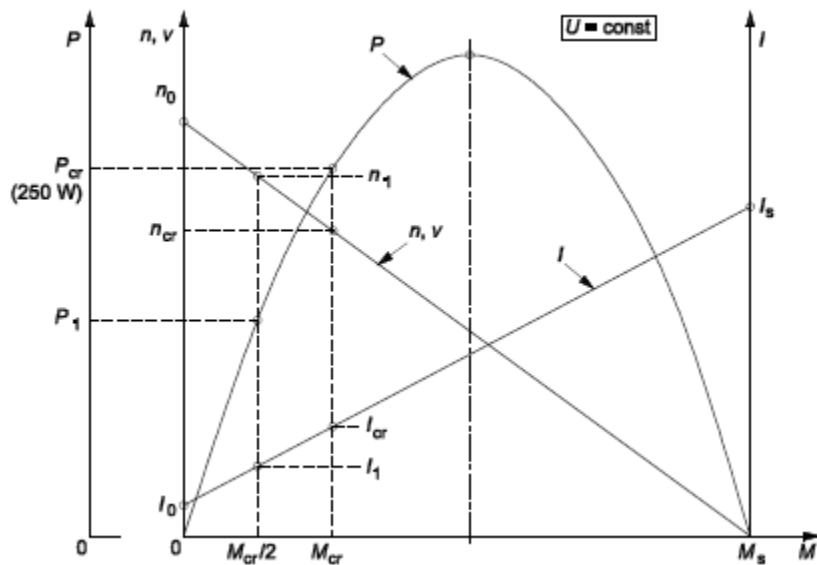

Figure B.1 — Relation between P, n and M

Quantities	Indices
U voltage [V]	cr continuous rated
M torque [Nm]	s standstill
n speed [rpm]	0 no load
v speed [km/h]	1 load point
I current [A]	$n_0 \equiv v_0 \leq 25 \text{ km/h}$
P output-power [W]	

The relationship between motor current I and torque M is linear according to:

$$M = k(I - I_0)$$

where

M torque [Nm]

k torque constant [Nm/A]

I current [A]

I_0 no load current [A]

The relation of power is:

$$P = \frac{2 \times \pi \times M \times n}{60}$$

where

P output-power[W]

n speed[rpm]

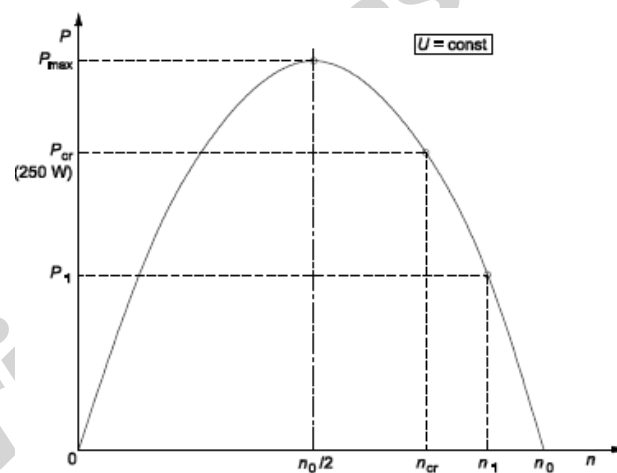

Figure B.2 — Speed-power diagram function

Because the natural speed-torque-diagram is a linear falling function (at constant voltage U) the output-power torque function (see Figure B.1) and the output-power-speed function is a parabolic one (see Figure B.2). Therefore, if the torque falls linear from M_{cr} (torque at P_{cr} – continuous rated power) to zero, the motor current falls linear to I_0 and the power P falls progressively from P_{cr} to zero.

The corresponding relations are:

$$P_1 > P_{cr} - P_1 \text{ or } P_1 > \frac{P_{cr}}{2} \text{ if } n_1 = \frac{(n_{cr} + n_0)}{2}$$

One can verify this relation in two steps:

Firstly, reducing the torque to $M_{cr}/2$, respectively increasing the speed to $n_1 = (n_{cr} + n_0)/2$, corresponding to $I_1 = (I_{cr} - I_0)/2$

Secondly, reducing the torque from $M_{cr}/2$ to zero respectively increasing the speed to no load speed n_0 , corresponding to no load current.

In the first step, the reduction of power is smaller than in the second one.

So, the power is progressively reduced and finally cut off as the EPAC reaches the maximum assistance speed.

All rights reserved
Reprints must investigate

Annex C
(informative)
Electromagnetic compatibility of EPAC and ESA

C.1 Conditions applying to EPAC and to electrical/electronic sub-assemblies (ESA)

C.1.1 Marking

All ESAs, with the exception of cables shall bear the following and these marks shall be indelible and clearly legible:

- a) make or name of the manufacturer of the ESAs and their components;
- b) trade description.

C.1.2 Requirements

C.1.2.1 General requirements

All EPAC and ESAs shall be designed and constructed in such a way that, under normal conditions of use, they meet the conditions laid down in this annex.

NOTE An overview of the electromagnetic radiation emission reference limits is given in Figure C.1.

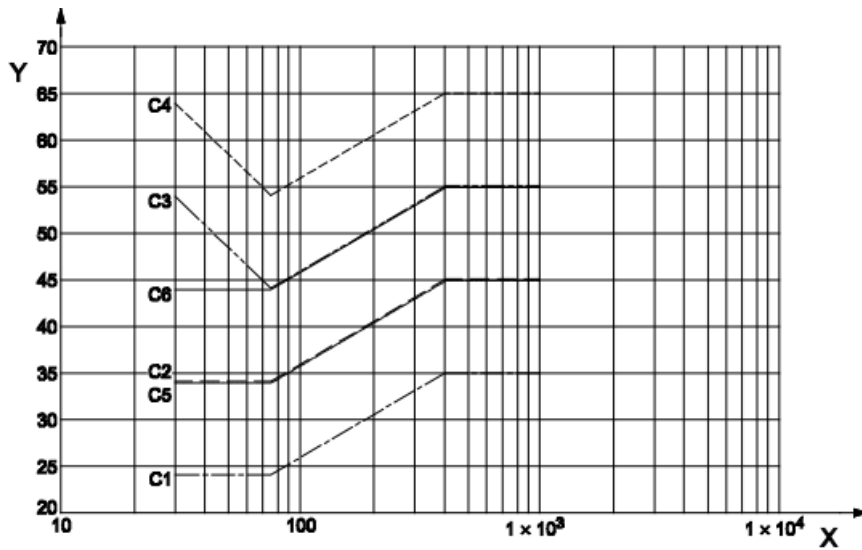

Key

- X frequency f in MHz
 Y reference limits L in dB [$\mu\text{V}/\text{m}$]
 C1 requirements relating to narrow-band radiation emission from EPAC, antenna at 10 m
 C2 requirements relating to broad-band radiation emission from EPAC, antenna at 10 m
 C3 requirements relating to narrow-band ESA radiation emission, antenna at 1m
 C4 requirements relating to broad-band ESA radiation emission, antenna at 1 m
 C5 requirements relating to narrow-band radiation emission from EPAC, antenna at 3 m
 C6 requirements relating to broad-band radiation emission from EPAC, antenna at 3 m

Figure C.1 — Overview of electromagnetic radiation emissions reference limits

Table C.1 — Overview of electromagnetic radiation emissions reference limits – Curves characteristics

Characteristic	Value	Band-width	Antenna distance [m]	Equation for L [dB($\mu\text{V}/\text{m}$)] within f [MHz]		
				30...75	75...400	400...1000
C1	mean value	narrow-band	10 ± 0.2	$24 = \text{const.}$	$24 + 15.13 \log(f/75)$	$35 = \text{const.}$
C2	quasi-peak	broad-band	10 ± 0.2	$34 = \text{const.}$	$34 + 15.13 \log(f/75)$	$45 = \text{const.}$
C3	mean value	narrow-band	1.0 ± 0.05	$54 - 25.13 \log(f/30)$	$44 + 15.13 \log(f/75)$	$55 = \text{const.}$
C4	quasi-peak	broad-band	1.0 ± 0.05	$64 - 25.13 \log(f/30)$	$54 + 15.13 \log(f/75)$	$65 = \text{const.}$
C5	mean value	narrow-band	3 ± 0.05	$34 = \text{const.}$	$34 + 15.13 \log(f/75)$	$45 = \text{const.}$
C6	quasi-peak	broad-band	3 ± 0.05	$44 = \text{const.}$	$44 + 15.13 \log(f/75)$	$55 = \text{const.}$

However, the measuring methods used in checking the immunity of EPAC and ESAs to electromagnetic radiation are described in C.4 and C.7.

C.1.2.2 Broad-band radiation from EPAC

C.1.2.2.1 General

The electromagnetic radiation generated by the EPAC type submitted for testing shall be measured by the method described in C.2.

EPAC are considered to be of one EPAC type if they are equal with respect to the following criteria:

- general layout of the electronic and/or electrical components;
- overall size, layout and shape of the engine mounting and the disposition of the high-voltage wiring (where present);
- raw material from which both the EPAC chassis and bodywork are constructed (e.g. a chassis or body made of glass fibre, aluminium or steel).

C.1.2.2.2 EPAC reference limits (broad-band)

C.1.2.2.2.1 If measurements are taken using the method described in C.2, in respect of a EPAC antenna distance of $(10,0 \pm 0,2)$ m, the radiation reference limit will be 34 dB $\mu\text{V}/\text{m}$ in the 30 MHz -75 MHz frequency band and 34-45 dB $\mu\text{V}/\text{m}$ in the 75 MHz to 400 MHz frequency band. This limit will increase by the frequency logarithm for frequencies above 75 MHz. In the 400 MHz -1 000 MHz frequency band the limit remains constant at 45 dB.

C.1.2.2.2.2 If measurements are taken using the method described in C.2, in respect of a EPAC -antenna distance of $(3,0 \pm 0,05)$ m, 10 dB shall be added to the limit.

C.1.2.2.2.3 The measured values expressed in dB (micro volts/m) shall be 2 dB below the reference limit for the EPAC submitted for testing.

C.1.2.3 Requirements relating to narrow-band radiation emissions from EPAC

C.1.2.3.1 General

The electromagnetic radiation from the EPAC submitted for testing is to be measured by the method described in C.3.

C.1.2.3.2 EPAC reference limits for EPAC narrow-band radiation

C.1.2.3.2.1 If measurements are taken using the method described in C.3, in respect of a EPAC antenna distance of $(10,0 \pm 0,2)$ m, the radiation reference limit will be 24 dB in the 30-75 MHz frequency band and 24-35 dB in the 75-400 MHz frequency band. This limit will increase by the frequency logarithm for frequencies above 75 MHz. In the 400-1 000 MHz frequency band the limit remains constant at 35 dB.

C.1.2.3.2.2 If measurements are taken using the method described in C.3, in respect of a EPAC antenna distance of $(3,0 \pm 0,05)$ m, 10 dB shall be added to the limit.

C.1.2.3.2.3 The measured values for the EPAC type submitted for testing expressed in dB (microvolts/m), shall be 2 below the reference limit.

For conformity of production testing do not remove the 2 dB from the reference limit.

C.1.2.4 Requirements regarding EPAC immunity to electromagnetic radiation

C.1.2.4.1 Measuring method

Tests to determine the immunity of the EPAC type to electromagnetic radiation shall be conducted in accordance with the method described in C.4.

C.1.2.4.2 EPAC immunity reference limits

C.1.2.4.2.1 If measurements are taken using the method described in C.4, the field strength reference level shall be 24 volts/m r.m.s. in over 90 % of the 20 MHz to 2 000 MHz frequency band and 20 volts/m r.m.s. over the whole 20 MHz to 2 000 MHz frequency band.

C.1.2.4.2.2 The EPAC representative of the type submitted for testing shall not display any deterioration in the direct control of the EPAC which might be observed by the driver or by any other road user when the EPAC in question is in the state defined in C.4, and when it is subjected to the field strength expressed in volts/m, which shall be 25 % above the reference level.

C.1.2.5 Requirements concerning broad-band ESA radiation

C.1.2.5.1 Measuring method

The electromagnetic radiation generated by the ESA submitted for component type-approval shall be measured by the method described in C.5.

C.1.2.5.2 ESA broad-band reference limits

C.1.2.5.2.1 If measurements are taken using the method described in C.5, in respect of ESA antenna distance of $(1,0 \pm 0,05)$ m, the radiation reference limit will be 64-54 dB (microvolts/m) within the 30-75 MHz frequency band, this limit decreasing by the frequency logarithm, and 54-65 dB (microvolts/m) in the 75400 MHz band, this limit increasing by the frequency logarithm.

In the 400-1 000 MHz frequency band the limit remains constant at 65 dB (1 800 microvolts/m).

C.1.2.5.2.2 The measured values for the ESA submitted for approval, expressed in dB (microvolts/m), shall be at least 2,0 dB below the reference limits.

C.1.2.6 Requirements concerning narrow-band ESA radiation emission

C.1.2.6.1 Method of measurement

The electromagnetic radiation generated by the ESA submitted for component

type-approval is to be measured in accordance with the method described in C.6.

C.1.2.6.2 ESA narrow-band reference limits

C.1.2.6.2.1 If measurements are taken using the method described in C.6, in respect of ESA antenna distance of $(1,0 \pm 0,05)$ m, the radiation reference limit will be 54-44 dB (microvolts/m) in the 30-75 MHz frequency band, this limit decreasing by the frequency logarithm, and 44-55 dB (microvolts/m) in the 75400 MHz band, this limit increasing by the frequency logarithm.

In the 400-1 000 MHz frequency band the limit remains constant at 55 dB (560 microvolts/m).

C.1.2.6.2.2 The measured values for the ESA submitted for competent type-approval, expressed in dB (microvolts/m), shall be at 2 dB below the reference limits.

For conformity of production testing do not remove the 2 dB from the reference limit.

C.1.2.7 Requirements concerning ESA immunity to electromagnetic radiation

C.1.2.7.1 Method of measurement

The immunity to electromagnetic radiation of the ESA submitted for component type approval will be tested by means of one of the methods described in C.7.

C.1.2.7.2 ESA immunity reference limits

C.1.2.7.2.1 If measurements are taken using the methods described in C.7, the immunity test reference levels will be 48 volts/m for the 150 mm stripline testing method, 12 volts/m for the 800 mm stripline testing method, 60 volts/m for the TEM cell testing method, 48 mA for the Bulk Current Injection (BCI) testing method and 24 volts/m for the Absorber lined Chamber testing method.

C.1.2.7.2.2 The ESAs representative of the type submitted for testing may not exhibit any malfunction which is able to cause any degradation on the direct control of the EPAC perceptible to the driver or other road user if the EPAC is in the state defined in Figure C.1 at a field strength or current expressed in appropriate linear units 25 % above the reference limit.

C.2 Method of measuring broad-band electromagnetic radiation from EPA

C.2.1 Measuring equipment

A quasi-peak detector shall be used to measure broad-band electromagnetic radiation.

Receivers with quasi-peak detectors shall be in accordance with EN 55016-1-1:2010, Clause 4.

For time efficiency it is possible to use a peak detector. Any peak measurements with results at or above the quasi-peak limit shall be re-measured using the

quasi-peak detector.

C.2.2 Test method

C.2.2.1 General

C.2.2.2 Test conditions

According to EN 55012.

C.2.2.3 State of the EPAC during the test

Apply a load in order to test at $75 \% \pm 10 \%$ of the continuous rated power declared by the manufacturer.

NOTE 1 It is possible to achieve the load by braking, home trainer.

NOTE 2 For example, it is possible that the test be performed when the engine is running alone or when the driver on it using the brake.

C.2.2.4 Antenna type, position and orientation

According to EN 55012.

C.2.3 Measurement

According to EN 55012.

C.3 Method of measuring narrow band electromagnetic radiation from EPAC

C.3.1 General

C.3.1.1 Measuring equipment

An average-value detector is used to measure narrow-band electromagnetic radiation.

NOTE The measuring equipment is described in EN 55012.

C.3.1.2 Test method

According to EN 55012.

C.3.1.3 Test conditions

According to EN 55012.

C.3.1.4 State of the EPAC during the tests

Apply a load in order to test at $75 \% \pm 10 \%$ of the continuous rated power declared by the manufacturer.

NOTE 1 It is possible to achieve the load by braking, home trainer.

NOTE 2 For example, it is possible that the test be performed when the engine is running alone or when the driver on it using the brake.

C.3.2 Antenna type, position and orientation

According to EN 55012.

C.4 Methods of testing EPAC immunity to electromagnetic radiation

C.4.1 General

These tests are designed to demonstrate the insensitivity of the EPAC to any factor which may alter the quality of its direct control. The EPAC shall be exposed to the electromagnetic fields, described in this Annex, and shall be monitored during the tests.

C.4.2 Expression of results

The field strengths shall be expressed in Volts/m for all the tests described in this annex.

C.4.3 Test conditions

The test equipment shall be capable of generating the field strengths in the range of frequencies defined in this Annex, and shall meet the (national) legal requirements regarding electromagnetic signal. The control and monitoring equipment shall not be susceptible to radiation fields whereby the tests could be invalidated.

C.4.4 State of the EPAC during the tests

C.4.4.1 The mass of the EPAC shall be equal to the mass in running order if required for performing the test.

- a) The engine shall turn the driving wheels at a constant speed predetermined by the testing authority in agreement with the EPAC manufacturer.
- b) All EPAC systems including light (if applicable) shall be operating normally.
- c) There shall be no electrical connection between the EPAC and the test surface and no connections between the EPAC and the equipment, save where so required by C.4.4.1 a) or C.4.4.2.
- d) The test shall be done in at least the following conditions:
 - 1) standstill mode (all EPAC systems including light activated, EPAC ready to be started, but no assistance is given by the motor);
 - 2) EPAC operating at 90 % -100 % of the maximum speed of the design "start-up assistance mode" maximum speed
 - 3) EPAC operating (with motor assistance) at 90 % of the design maximum assistance speed.

Contact between the wheels and the test surface is not regarded as an electrical connection.

Where ESA's are involved in the direct control of the EPAC and where these systems do not operate under the conditions described in C.4.4.1 a), the testing authority is allowed to carry out separate tests on the systems in question under conditions agreed with the EPAC

manufacturer.

C.4.4.2 During the tests on the EPAC, only non-interference-generating equipment may be used.

C.4.4.3 Under normal conditions, the EPAC shall be facing the antenna.

C.4.5 Type, position and orientation of the field generator

C.4.5.1 Type of field generator

- a) The criterion for the selection of the field generator type is the capacity of the latter to attain the prescribed field strength at the reference point (see C.4.5.4) and at the appropriate frequencies.
- b) Either the antenna(s) or a transmission line system (TLS) may be used as the field generating device(s).
- c) The design and orientation of the field can be generated is polarized both horizontally and vertically at frequencies between 30 MHz and 2000 MHz.

C.4.5.2 Measurement height and distance

C.4.5.2.1 Height

C.4.5.2.1.1 The phase mid-point of all antennas shall not be less than 1,5 m above the EPAC plane.

C.4.5.2.1.2 No part of the antenna radiator elements shall be less than 0,25 m from the EPAC plane.

C.4.5.2.2 Measuring distance

C.4.5.2.2.1 Greater homogeneity of the field may be obtained by placing the field generator as far as technically possible from the EPAC. This distance will normally be in the range 1 to 5 m.

C.4.5.2.2.2 If the test is carried out in a closed installation, the radiator elements of the field generator shall not be less than 0,5 m from any type of radio frequency absorption material and not less than 1,5 m from the wall of the installation in question. There shall be no absorption material between the transmitting antenna and the EPAC under test.

C.4.5.3 Position of the antenna in relation to the EPAC

C.4.5.3.1 Reference point

C.4.5.3.1.1 The field generator shall be positioned in the median longitudinal plane of the EPAC.

C.4.5.3.1.2 No part of the TLS, except the EPAC plane, may be less than 0,5 m from any part of the EPAC.

C.4.5.3.1.3 Any field generator placed above the EPAC shall cover at least 75 % of the length of the EPAC.

C.4.5.3.1.4 The reference point is the point at which the field strengths are established and is defined as follows:

- a) horizontally, at least two metres from the antenna phase mid-point or, vertically, at least one metre from the TLS radiator elements;
- b) in the median longitudinal plane of the EPAC;
- c) at a height of $(1,0 \pm 0,05)$ m above the EPAC plane;

or

-at $(1,0 \pm 0,2)$ m behind the vertical centre line of the EPAC's front wheel in the case of tricycles;

or

-at $(0,2 \pm 0,2)$ m behind the vertical centre line of the EPAC's front wheel in the case of bicycles.

C.4.5.4 Position of the EPAC

If it is chosen to subject the rear part of the EPAC to radiation, the reference point shall be established as stated in C.4.5.3.1. In this case the EPAC will be positioned with its front part facing in the opposite direction to the antenna and as if it had been rotated horizontally through 180 degrees about its central point. The distance between the antenna and the nearest part of the outer surface of the EPAC shall remain the same.

C.4.6 Requisite test and condition

C.4.6.1 Range of frequencies, duration of the tests, polarization

The EPAC shall be exposed to electromagnetic radiation in the 20-2000 MHz frequency range.

- a) Measurement shall be made in the 20 MHz to 2000 MHz frequency range with frequency steps according to ISO 11451-1, with a dwell time of $(2 \pm 0,2)$ s for each frequency.
- b) The vertical polarization modes described in C.4.5.1 c) shall be selected by common agreement between manufacturer and testing body.
- c) All other test parameters are as defined in this clause.

C.4.6.2 Tests to check deterioration in direct control

C.4.6.2.1 A EPAC is deemed to fulfil the requisite immunity conditions if, during the tests carried out in the manner required by this clause, there are no abnormal changes in the speed of the EPAC's drive wheels, there are no signs of operational deterioration which might mislead other road users and there are no other noticeable phenomena which could result in a deterioration in the direct control of the EPAC.

C.4.6.2.2 For the purpose of monitoring the external part of the EPAC and of determining whether the conditions laid down in C.4.6.2.1 have been met, a video camera may be used.

C.4.6.2.3 If a EPAC does not meet the requirements of the tests defined in C.4.6.2, steps shall be taken to verify that the faults occurred under normal conditions and are not attributable to spurious fields.

C.4.7 Generation of the requisite field strength

C.4.7.1 Test method

a) The “substitution method” is to be used for the purpose of creating the field test conditions.

b) Substitution method: for each test frequency required, the RF power level of the field generator shall be set so as to produce the required test field strength at the reference point of the test area without the EPAC being present. This RF input power level, as well as all other relevant settings on the field generator shall be recorded in the test report (calibration curve). The recorded information is to be used for type-approval purposes. Should any alterations be made to the equipment at the test location, the substitution method shall be repeated.

c) The EPAC is then brought to the test installation and positioned in accordance with the conditions laid down in C.4.5. The power required by C.4.7.1 b) is then applied to the field generator for each of the frequencies indicated in C.4.6.1 a).

d) Whatever field-definition parameter is chosen in accordance with the conditions laid down in C.4.7.1 b), the same parameter shall be used in order to determine the strength of that field throughout the test.

e) For the purposes of this test, the same field generating equipment and the same equipment configuration shall be used as in the operations conducted in pursuance of C.4.7.1 b).

f) Field strength measuring device:

Under the substitution method, the device used to determine the field strength during the calibration stage should take the form either of a compact isotropic probe for measuring field strength or of a calibrated receiving antenna.

During the calibration phase of the substitution method, the phase mid-point of the field-strength measuring device shall coincide with the reference point.

If a calibrated receiving antenna is used as the field strength measuring device, readings will be obtained in three directions at right angles to each other. The equivalent isotropic value corresponding to these measurements is to be regarded as the field strength.

- g) In order to take account of differences in EPAC geometry, a number of reference points shall be established for the relevant test installation.

C.4.7.2 Field strength contour

During the calibration phase (before the EPAC is positioned on the test surface) the field strength shall not be less than 50 % of the nominal field strength at the following locations:

- a) for all field-generating devices, $(1,0 \pm 0,02)$ m on either side of the reference point on a line passing through this point, and perpendicular to the median longitudinal plane of the EPAC;
- b) in the case of a TLS, $(1,5 \pm 0,02)$ m on a line passing through the reference point, and situated in the median longitudinal plane of the EPAC.

C.4.7.3 Characteristics of the test signal to be generated

C.4.7.3.1 Peak value of the modulated test field strength

The peak value of the modulated test field strength shall correspond to that of the unmodulated test field strength, the actual value in volts/m of which is defined in C.1.2.4.2.

C.4.7.3.2 Test signal waveform

The test signal shall be a radio-frequency sinusoidal wave, amplitude-modulated by a sinusoidal 1 kHz wave at a modulation rate m of $0,8 \pm 0,04$ (peak value).

C.4.7.3.3 Modulation rate

The modulation rate m is defined as follows:

$m \geq \text{NUM} > \text{peak envelope value} - \text{minimum envelope value} > \text{DEN} > \text{peak envelope value} + \text{minimum envelope value}$ The envelope describes the curve formed by the edges of the modulated carrier as seen on an oscillograph.

C.4.8 Inspection and monitoring equipment

For the purposes of monitoring the external part of the EPAC and the passenger compartment and of determining whether the conditions laid down in C.4.6.2.2 have been met, use will be made of a video camera or cameras.

C.5 Method of measuring broad-band electromagnetic radiation from separate technical units (ESA)

C.5.1 General

C.5.1.1 Measuring equipment

A broad peak detector shall be used to measure broad-band electromagnetic emissions.

NOTE The measuring equipment is described in EN 55012.

C.5.1.2 Test method -Test conditions

According to EN 55025:2008, absorber lined chamber.

C.5.2 State of the ESA during the test

According to EN 55025:2008, absorber lined chamber.

C.5.3 Antenna type, position and orientation

According to EN 55025:2008, absorber lined chamber.

C.6 Method of measuring narrow-band electromagnetic radiation from separate technical units (ESAs)

C.6.1 General

C.6.1.1 Measuring equipment

A average-value detector is used to measure the narrow-band electromagnetic radiation. NOTE The measuring equipment is described in EN 55012.

C.6.1.2 Test method

According to EN 55025:2008, absorber lined chamber.

C.6.2 Test conditions

According to EN 55025:2008, absorber lined chamber.

C.6.3 State of the ESA during the tests

According to EN 55025:2008, absorber lined chamber.

C.6.4 Antenna type, position and orientation

According to EN 55025:2008, absorber lined chamber.

C.7 Methods of testing the ESA immunity to electromagnetic radiation

C.7.1 General

These tests are designed to demonstrate the insensitivity of the ESA to any factor which may alter the quality of its direct control. The ESA shall be exposed to the electromagnetic fields, described in C.7, and shall be monitored during the tests.

C.7.2 Expression of results

The field strengths shall be expressed in either in mA (BCI) or in Volts/m for all the other tests described in C.7.

C.7.3 Test conditions

The test equipment shall be capable of generating the current or the field strengths in the range of frequencies defined in this Annex, and shall meet the (national) legal requirements regarding electromagnetic signal. The control and monitoring equipment shall not be susceptible to radiation fields whereby the tests could be invalidated.

C.7.4 State of the ESA during the tests

Where ESA's are involved in the direct control of the EPAC and where these systems do not operate under the conditions described in C.4.4.1 a), the testing authority may carry out separate tests on the systems in question under conditions agreed with the EPAC manufacturer.

C.7.5 Requisite test and condition

C.7.5.1 Test methods

ESAs shall comply with the limits (C.1.2.7.2) for one of the following test methods, at the manufacturer's discretion, within the range of 20 -2 000 MHz:

- a) stripline test;
- b) bulk current injection test;
- c) TEM-cell test;
- d) absorber lined Chamber, only in vertical polarization.

To avoid radiation from electromagnetic fields during tests, it is recommended to carry them out in a shielded area.

C.7.5.2 Range of frequencies, duration of the tests, polarization

The EPAC shall be exposed to electromagnetic radiation in the 20-2 000 MHz frequency range.

- a) Measurement shall be made in the 20 to 2000 MHz frequency range with frequency steps according to ISO 11452-1, with a dwell time of $(2 \pm 0,2)$ s for each frequency.
- b) All other test parameters are as defined in this clause.

C.7.5.3 Tests to check deterioration in direct control

C.7.5.3.1 A EPAC is deemed to fulfil the requisite immunity conditions if, during the tests carried out in the manner required by this clause, there are no abnormal changes in the speed of the EPAC's drive wheels, there are no signs of operational deterioration which might mislead other road users and there are no other noticeable phenomena which could result in a deterioration in the direct control of the EPAC.

C.7.5.3.2 For EPAC observation purposes, only the monitoring equipment described in C.4.6.2.2 may be used.

C.7.5.3.3 If a EPAC does not meet the requirements of the tests defined in C.4.6.2, steps shall be taken to verify that the faults occurred under normal conditions are not attributable to spurious fields.

C.7.6 Generation of the requisite field strength

C.7.6.1 Test method

C.7.6.1.1 Stripline test

According to ISO 11452-5.

C.7.6.1.2 BCI test

According to ISO 11452-4.

C.7.6.1.3 TEM cel test

According to ISO 11452-3.

C.7.6.1.4 Absorber line Chamber test

According to ISO 11452-2.

C.7.6.2 Characteristics of the test signal to be generated

C.7.6.2.1 Peak value of the modulated test field strength

The peak value of the modulated test field strength shall correspond to that of the unmodulated test current or field strength, the actual value in mAmps or in volts/m of which is defined in C.1.2.7.2.

C.7.6.2.2 Test signal waveform

The test signal shall be a radio-frequency sinusoidal wave, amplitude-modulated by a sinusoidal 1 kHz wave at a modulation rate m of $0,8 \pm 0,04$.

C.7.6.2.3 Modulation rate

The modulation rate m is defined as follows:

$m \geq \frac{\text{NUM} > \text{peak envelope value} - \text{minimum envelope value}}{\text{DEN} > \text{peak envelope value} + \text{minimum envelope value}}$ The envelope describes the curve formed by the edges of the modulated carrier as seen on an oscillograph.

C.7.7 Inspection and monitoring equipment

For the purposes of monitoring the external part of the EPAC and of determining whether the conditions laid down in C.4.6.2.2 have been met, use will be made of a video camera or cameras.

C.8 ESD test

ESD test shall be performed according to EN 61000-4-2 at 4 kV for contact discharge and 8 kV for air discharge with immunity criteria B.

Annex D
(informative)
Steering geometry

The steering geometry employed, as shown in Figure D.1, will generally be dictated by the use for which EPAC is intended but it is nevertheless recommended that:

- a) the steering head angle be not more than 75° and not less than 65° in relation to the ground line; and
- b) the steering axis intersects a line perpendicular to the ground line, drawn through the wheel centre, at a point not lower than 15 % and not higher than 60 % of the wheel radius when measured from the ground line.

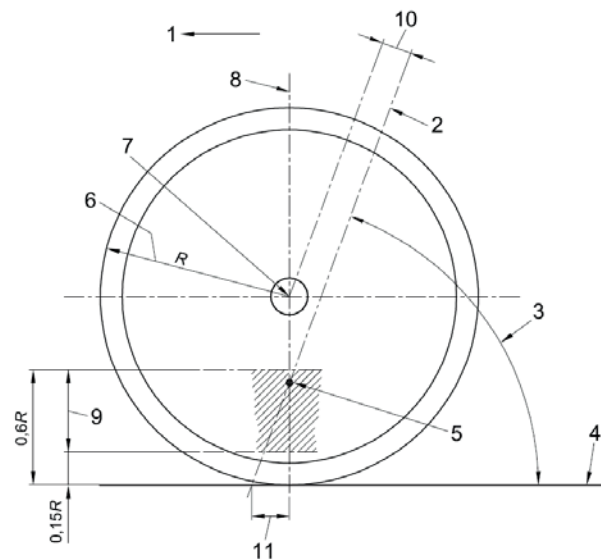

- 1 Direction of travel
- 2 Steering axis
- 3 Steering head angle
- 4 Ground line
- 5 Intersection point
- 6 Wheel radius
- 7 Wheel centre
- 8 Perpendicular to ground line
- 9 Clearance
- 10 Offset
- 11 Trail

Figure D.1 — Steering geometry

Annex E
(informative)
Dummy fork characteristics

The test forks shall be designed to mount in a manner similar to the original fork, or in a manner using typical procedures (see Annex B).

The test forks when mounted shall be the same length (axle to race), L , as the longest fork designed for use with the frame.

The deflection of the test fork shall be measured in the direction of the force application at the front axle centre, from the resulting application of a vertical force of 1 200 N. The fork shall be secured in a horizontal position by constraining the steerer tube by means of a false head tube (with bearings) equal to 150 mm in length. The steerer tube shall be secured as in a bicycle with the crown race seat adjacent to the false head tube lower bearing assembly. (See Figure G.1 in Annex G).

a) The deflection ratio, D_r , for the Test fork for the Horizontal Loading Fatigue test and the Vertical Loading Fatigue test shall not exceed the value of 1,0 when computed as follows:

$$D_r = \frac{K_1 \times 10\,000 \times \delta}{L^3}$$

where

D_r is the deflection ratio;

K_1 is 1 417, a constant;

L is the fork length, expressed in millimetres;

δ is the deflection, expressed in millimetres.

EXAMPLE

Fork length $L = 460$ mm

Deflection $\delta = 6,85$ mm, from which

Deflection ratio D_r

$$\begin{aligned} D_r &= \frac{K_1 \times 10\,000 \times \delta}{L^3} \\ &= \frac{1\,417 \times 10\,000 \times 6,85}{460^3} \\ &= 0,99721 \leq 1,0 \end{aligned}$$

b) The deflection ratio, D_r , for the Test fork for the Impact test shall not exceed the value of 1,0 when computed as follows:

$$D_r = \frac{K_2 \times 10000 \times \delta}{L^3}$$

where

D_r is the deflection ratio;

K_2 709 , a constant;

L is the fork length, expressed in millimetres;

δ is the deflection, expressed in millimetres.

All rights reserved
Reprints must investigate

Annex F
(Informative)

Explanation of the method of least squares for obtaining line of best fit and $\pm 20\%$ limit lines for braking performance linearity

The readings taken in the test specified in 4.3.5.11 can be expected to lie near some straight line that can be drawn through them. Although in practice one might draw a good straight line through the points by eye, the method of least squares given here provides a criterion for minimising the discrepancies, and permits a line to be selected that has a claim to be called the best fit.

The line of best fit is the line that minimises the sum of the squares of the differences between the observed results and the corresponding results predicted by the line.

The relationship between the variables is considered to be of the form:

$$y = a + bx$$

Where

x is the independent variable, and is known precisely (in this case the load applied to the pedal);

y is the dependent variable, and is observed but with a degree of uncertainty (in this case, the braking force at the wheel);

a and b are unknown constants and have to be estimated.

For a series of n readings, this relationship can be resolved by taking a minimum of the sum of the squares of the difference to give:

$$b = \frac{n \sum xy - \sum x \sum y}{n \sum x^2 - \sum x \sum x}$$

Taking:

$$\bar{y} = \frac{\sum y}{n} \quad \text{and} \quad \bar{x} = \frac{\sum x}{n}$$

$$b = \frac{\sum xy - \bar{y} \sum x}{\sum x^2 - \bar{x} \sum x}$$

Then a may be found by substitution:

$$a = \bar{y} - b\bar{x}$$

EXAMPLE The following four values of x and y are noted during a test, from which:

· $\sum xy$, $\sum x^2$, \bar{x} and \bar{y} are calculated as shown:

No.	X (pedal force , N)	Y (braking force , N)
1	90	90
2	150	120
3	230	160
4	300	220
Sum	$\sum x=770$	$\sum y=590$
Mean	$X=192.5$	$Y=147.5$

No.	XY	X^2
1	8100	8100
2	18000	22500
3	36800	52900
4	66000	90000
Sum	$\sum xy=128900$	$\sum X^2=173500$

$$b = \frac{\sum xy - \bar{y} \sum x}{\sum x^2 - \bar{x} \sum x}$$

$$= \frac{128\,900 - (147,5 \times 770)}{173\,500 - (192,5 \times 770)}$$

$$= 0,606$$

$$a = \bar{y} - b\bar{x}$$

$$= 147,5 - (0,606 \times 192,5)$$

$$= 30,8$$

The line of best fit is therefore:

$$y = 30,8 + 0,60x$$

and the $\pm 20\%$ limit lines are:

$$y_{\text{lower}} = \frac{80}{100}(30,8 + 0,606x)$$

$$= 24,64 + 0,485x$$

$$y_{\text{upper}} = \frac{120}{100}(30,8 + 0,606x)$$

$$= 36,96 + 0,727x$$

The results are shown graphically in Figure F.1.

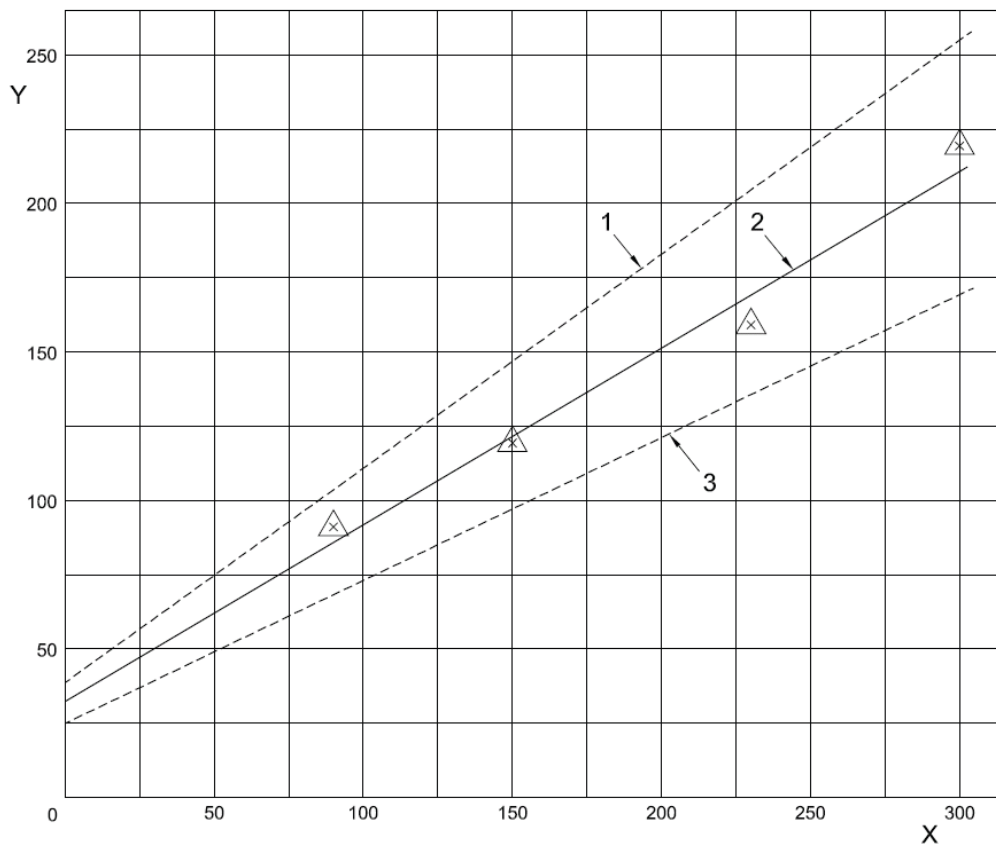

Y Braking force, N

X Input force, N

1 +20 % Limit

2 Line of best fit

3 -20 % Limit

Figure F.1 — Graph of lever force or pedal force (input force) against braking force, showing line of best fit and $\pm 20\%$ limit lines

Annex G
(Informative)
Fork mounting fixture

The fork shall be mounted in a fixture representative of the head-tube and gripped in the normal head-bearings. The distance between the bearings can have an influence on the results. Therefore, when known the real mounting distance shall be used with a tolerance of ± 5 mm. If no indication about the distance is given, a value of (150 ± 5) mm shall be taken. The measurement points are taken from the middle of the bearings. Examples of distance measurements are given in Figure G.1.

During loading, the fork steerer will bend and may touch the dummy head-tube. The design of the dummy tube shall be such that this contact can't occur.

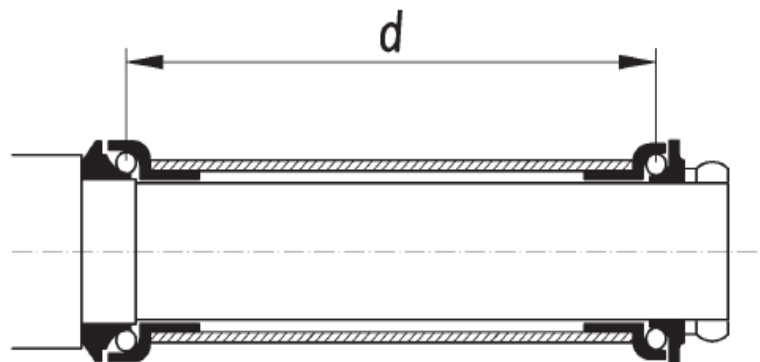

a) Measurement with external cup bearings

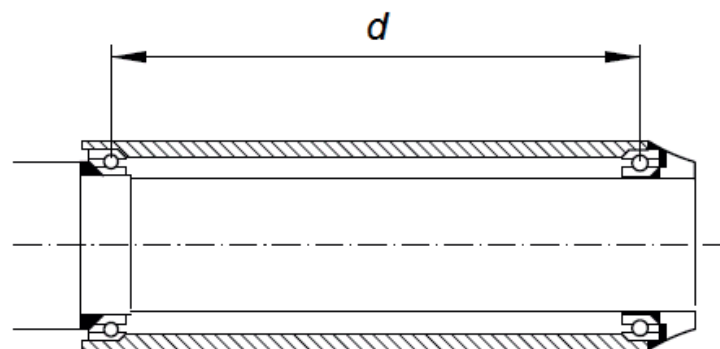

b) Measurement with integrated bearings

d Distance between the bearings

Figure G.1 — Examples of distance measurements

Annex H
(informative)
Wheel/tyre assembly - Fatigue test

H.1 Requirements

When tested by the method described in H 2, there should be no fractures, detachments or visible cracks in any part of the wheel, no loss of air pressure in the tyre due to damage from the wheel to the tyre or the inner tube (where fitted), and the undamaged tyre should remain on the rim. When measured by the method described in 4.3.9.1 the racing bicycle run-out shall not exceed 1 mm and the other type bicycle shall not exceed 1.2 mm.

H.2 Test method

Assemble the wheel, tyre and inner tube (when fitted) and inflate the tyre to 90 % of the maximum pressure, which is moulded on the side wall of the tyre.

Mount the wheel/tyre assembly free to rotate on its axle, and free to move in vertical direction. Load the wheel assembly by means of dead weights against a drum equipped with equally spaced, transverse, metallic slats such that the radial force applied to the wheel/tyre assembly is 640 N. The wheel and drum axes shall be vertically aligned.

An example of a test arrangement is shown in Figure I.1, in which the wheel axle is fixed between the free ends of a pair of pivoted arms that extend horizontally with the tyre contacting the drum between the slats.

The diameter of the drum shall be in the range 500 mm to 1 000 mm, and the slats shall have a width of $50 \text{ mm} \pm 2,5 \text{ mm}$, a thickness of $10 \text{ mm} \pm 0,25 \text{ mm}$, and shall have 45° chamfered edges of half their thickness. The circumferential spacing between the centrelines of two consecutive slats shall be not less than 400 mm.

Rotate the drum to give a linear surface speed of 25 km/h ($\pm 10 \%$) for a period to provide 750 000 impacts between the tyre and the slats.

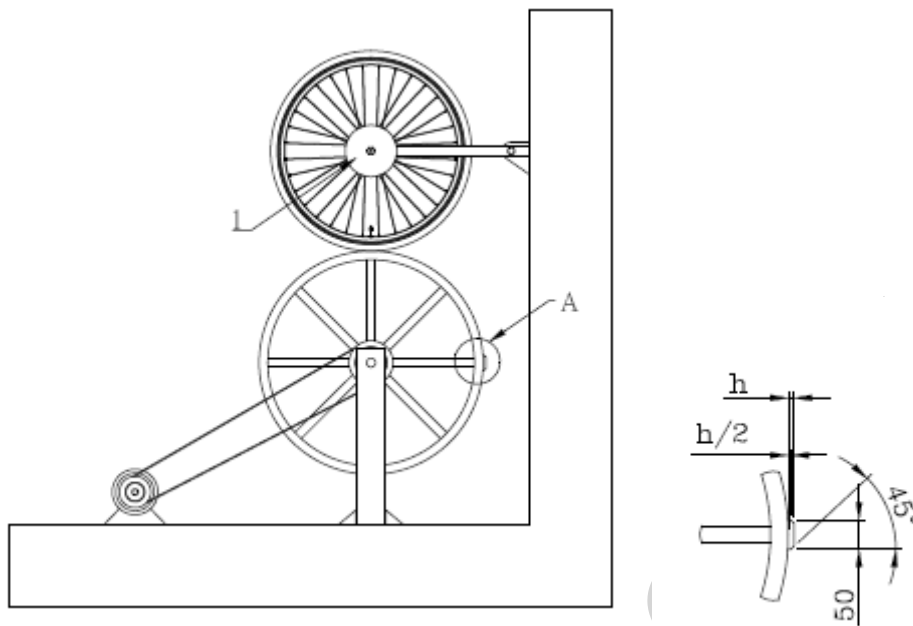

- 1 Total force on the axle 640 N

Figure H.1 — Wheel/tyre assembly: fatigue test

Annex I (informative)

Light, warning device, on/off symbols

Figures I.1 to I.3 gives the symbol to be used for light, warning device and on/off symbols.



Figure I.1 — Power on/off symbol



Figure I.2 — Light symbol



Figure I.3 — Electric horn symbol

Annex J (informative)

Walk assist mode symbols

Figures J.1 and J.2 gives two examples of symbols which may be used for the start-up assistance mode.



Figure J.1 — Assistance mode symbol n°1



Figure J.2 — Assistance mode symbol n°2

Annex K (informative)

Dynamic strength test on fully assembled bicycle

J.1 Requirement

When tested by the method described in J.2, there should be no system or component failure and no loosening or misalignment of the saddle, handlebar, controls, lighting equipment, or reflectors, and the function of electric power assisted should be normal.

J.2 Machine test

Mount a fully assembled electric power assisted bicycle on a test machine. The following weights should be applied:

- one 36 kg weight with a pin for insertion in the seat-post and divided into two halves to be hung, one on each side;
- two 18 kg weights with fixtures for attaching them to the cranks in place of the pedals;
- two 6,75 kg weights with fixtures for attaching them to each side of the handlebar;
- one 10 kg, 18 kg, or 25 kg weight with the dimensions 240 mm × 240 mm on the luggage carrier.
- Electric power assisted bicycle should include controllers, motors, batteries and other assisted power system.

An example of a test arrangement is shown in Figure J.1, in which the Electric power assisted bicycle is mounted on two drums. The diameter of the drums should be in a range from 500 mm to 1 000 mm, and the slots should have a width of 50 mm ± 2,5 mm, a thickness of 10 mm ± 0,25 mm, and 45° chamfered edges of half their thickness. The circumferential spacing between the centrelines of two consecutive slots should be not less than 400 mm.

Rotate the drums to give a linear surface speed of 8 km/h (±10 %) for a period of 6 h.

The tyres of the bicycle should be inflated to the maximum inflation pressure.

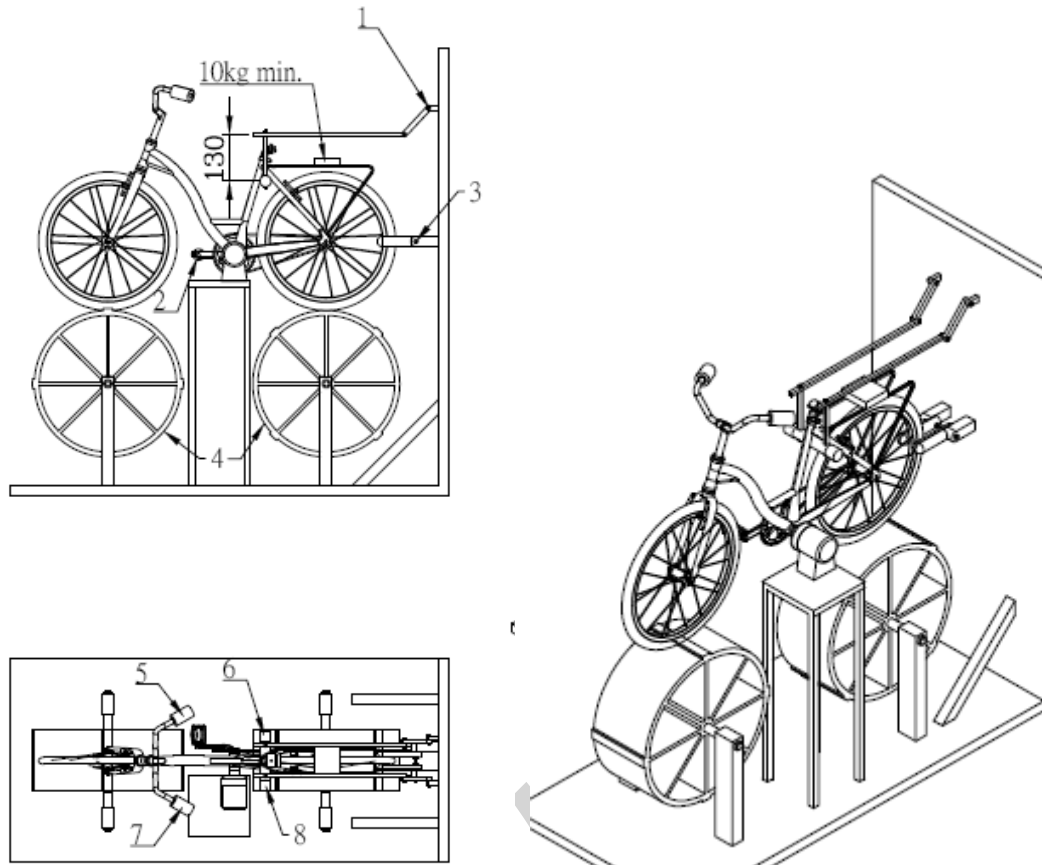

1. adjustable height
2. weight, 18 kg
3. height adjustable
4. drum diameter, 760 mm
5. weight, 6,75 kg
6. weight, 18 kg
7. weight, 6,75 kg
8. weight, 18 kg

Figure J.1 — Dynamic strength test on fully assembled bicycle

Annex L

Electrically power assisted bicycles- Test method of travelling distance

1. Application range: the test is prepared for the electrically power assisted bicycles- Test method of travelling distance by the test machine.
2. Definition of travelling distance: The maximal distance that the electrically power assisted bicycle moves when been driven on the test machine during the operation of the assistance system after the attached charger fully charges the battery of the electrically power assisted bicycle.
3. Test machine: the test machine tests the output of the electrically power assisted bicycle according to the driving torque and the rotation number of the roller after the driving wheel of the electrically power assisted bicycle is disposed on the roller to transmit the rotation force of the driving wheel to the roller (the test machine is as shown in Fig. K1).
4. Equivalent inertia mass: the test machine simulates that the test technician sits on the electrically power assisted bicycle to measure the mass needed for generating the inertia force when the electrically power assisted bicycle is driving on the road. The mass should be adjusted by the flywheel installed on the roller of the test machine.
5. Test condition:
 - a) The temperature of the test environment is $23\pm 5^{\circ}\text{C}$.
 - b) Please adjust the air pressure of the tire to the regulated value before the test.
 - c) The battery of the electrically power assisted bicycle provided for test is fully charged by the attached charger of the electrically power assisted bicycle; the surrounding temperature when the battery is being charged is set as $23\pm 5^{\circ}\text{C}$.
6. Types of test method: there are three test methods for testing the travelling distance of the electric assisted bicycle, including continuously driving over uphill road of 2° , continuously driving over uphill road of 4° and continuously driving over uphill road of 6° . Please refer to Table 1 for the information about the speed-changing positions of the speed and speed-changing devices.

Table 1 Types of test method

Type of the test method	Speed (km/h)	Speed-changing position
Continuously driving over uphill road of 2°	10	Middle position (Note 1)
Continuously driving over uphill road of 4°	7	Position with lowest speed
Continuously driving over uphill road of 6°		

Note (1): the integral position obtained by dividing the position with highest speed by 2, and then rounding the result.

7. Test device

7.1 Test machine: the test machine is set, manipulated and operated according to the following settings.

- a) The equivalent inertia mass set in the test machine is the mass value obtained by adding 60kg to the electrically power assisted bicycle for test (the default weight of the body weight of the rider.). The value is set as the standard value of Table 2.

Table 2 Standard values of equivalent inertia mass

Unit: kg

The weight of the electrically power assisted bicycle + 60kg	Standard value of equivalent inertia mass
63.76~66.25	65
66.26~68.75	67.5
68.76~71.25	70
71.26~73.75	72.5
73.76~76.25	75

76.26~78.75	77.5
78.76~81.25	80
81.26~83.75	82.5
83.76~86.25	85
86.26~88.75	87.5
88.76~91.25	90
91.26~93.75	92.5
93.76~96.25	95
96.26~98.75	97.5
98.76~101.25	100

b) After the equivalent inertia mass is set, please warm up the machine for 30 minutes.

c) The driving impedance which the dynamometer of the test machine applies to the driving wheel of the electrically power assisted bicycle is calculated according to the following equation.

$$F = R + 0.027V^2 + 9.8W\sin\theta$$

F: driving impedance (N)

V: speed (km/h)

W: standard value of equivalent inertia mass (kg)

θ : angle of uphill road ($^{\circ}$)

R: rolling impedance (N). When the wheel has yet to be installed on the roller of the dynamometer of the test machine, the average rolling impedance is set as 2.6.

0.027: air impedance coefficient [$N / (km/h)^2$]

7.2 Driving motor: the external driving motor of the electrically power assisted bicycle, which can control the revolution number, and can monitor the revolution number and the output.

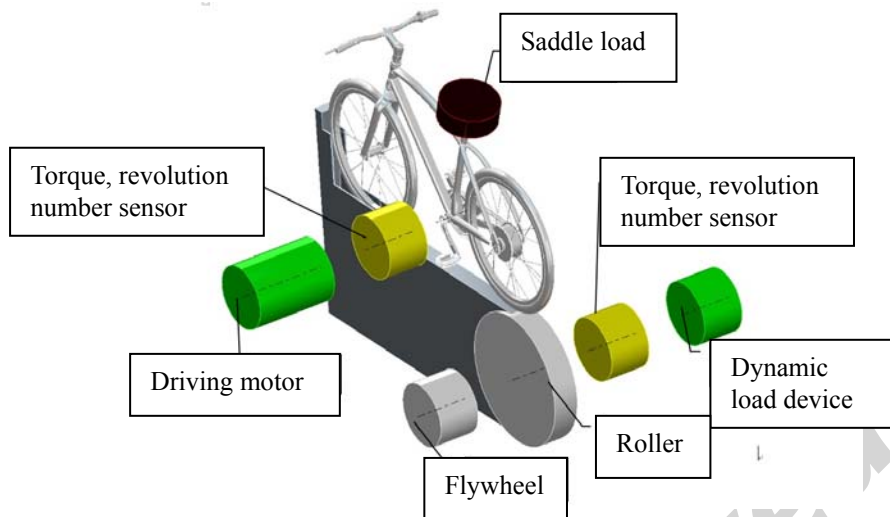

Figure K1 Concept diagram of test machine

8. The test should be performed according to the following order:
- Put the electrically power assisted bicycle for test on the test machine.
 - Put the load of 60kg on the saddle.
 - Set the speed, the speed-changing position of the electrically power assisted bicycle in Table 1, and set the driving impedance.
 - Please use the external motor to drive the crank of the electrically power assisted bicycle to generate the roller surface speed in Table 1 according to the type of the test method. The variation range of the revolution speed of the crank is $\pm 2\%$.
 - Please test the driving distance from the electrically power assisted bicycle's crank starting to revolve to the electrically power assisted bicycle's assistant force stopping (Note 2); the unit for resting the endurance is km. Please round off to the 2nd decimal place.

Note (2): the stopping of the assistant force means that the force output current of the assistant motor is cut and the electrically power assisted bicycle cannot be assisted by the assistant motor even if the electrically power assisted bicycle is driving.

Annex M

Assistant force test for electrically power assisted bicycles

1. Application range: the test is prepared for performing the assistant force test by using the test machine to test the electrically power assisted bicycle.
2. Definition of assistant force: the assistant force means driving the assistant device to assist the output; the assistant force ratio means the ratio of the revolution input of the crank shaft to the assistant output provided by driving the assistant device.
3. Test machine: the test machine is to test the output of the electrically power assisted bicycle according to the driving torque transmitted to the revolution shaft of the roller and the revolution number of the roller when the driving wheel of the electrically power assisted bicycle is disposed on the roller to transmit the revolution of the driving wheel to the roller (the test machine is as shown in Fig. L1).
4. Test conditions
 - a) The temperature of the test environment is $23\pm 5^{\circ}\text{C}$.
 - b) Please adjust the air pressure of the tire to the regulated value before the test.
 - c) The battery of the electrically power assisted bicycle provided for test is fully charged by the attached charger of the electrically power assisted bicycle; the surrounding temperature when the battery is being charged is set as $23\pm 5^{\circ}\text{C}$.
 - d) Please properly apply pressure to the tire, and put the load of 50kg on the saddle; the mass is adjusted by the flywheel disposed on the roller of the test machine.
 - e) If the bicycle has the speed-changing device, the speed-changing device should be set as the speed-changing position with the maximal assistant force range.
 - f) Please respectively make the settings according to the target values of the set the driving speed and the wheel driving force of the setting condition 1 and the setting condition 2 to test the load.
5. Test method and calculation equations
 - 5.1) Major test items and units
 - a) Input revolution speed: N
 - The revolution speed of using the crank to drive the device.
 - Unit: min^{-1} ; please round off to the 1st decimal place.
 - b) Input torque: T
 - The torque of using the crank to drive the device.

-Unit: Newton-meter (N-m); please round off to the 2nd decimal place.

c) Driving speed: V

-The driving speed of the test machine in use.

-Set the tolerance lower than 5% of the target value.

-The unit is expressed by kilometer per hour (km/h); please round off to the 1st decimal place.

d) Wheel driving force: F

-The driving force calculated by using the dynamometer of the test machine.

- Set the tolerance lower than 5% of the target value.

-The unit is Newton (N), which is set as an integral (please round off to the 1st decimal place.).

e) Power loss of test machine: Pcl

- Please use the coasting or motor driving methods to test the power loss of the test machine.

-Unit: Watt (W), which is set as an integral (please round off to the 1st decimal place.).

5.2) Calculation equations

a) Revolution input of crank: P1

$$P1 = 0.105 \times N \times T$$

Here, P1: revolution input of crank (W)

N: input revolution speed (min^{-1})

T: input torque (N · m)

And, the unit is expressed by Watt (W), which is set as an integral (please round off to the 1st decimal place).

b) Driving output of the bicycle before correction: P2'

$$P2' = 0.278 \times V \times F$$

Here, P2': driving output of the bicycle before correction (W)

V: driving speed (km/h)

F: driving force of wheel (N)

And, the unit is expressed by Watt (W), which is set as an integral (please round off to the 1st decimal place).

c) Driving output of the bicycle after correction: P2

$$P2 = P2' + Pcl$$

Here, P2: driving output of the bicycle after correction (W)

P2': Driving output of the bicycle before correction (W)

Pcl: power loss of test machine (W)

And, the unit is expressed by Watt (W), which is set as an integral (please round off to the 1st decimal place).

d) Assistant force ratio: α

$$\alpha = (P2 - P1) / P1$$

P1: revolution input of crank (W)

P2: driving output of the bicycle after correction (W)

And, the expressed place is the 2nd place (please round off to the 3rd decimal place).

6. Test device

6.1 Please use the driving motor, the torque and the revolution number sensors to form the crank driving device, and then perform the revolution input for the crank to measure the revolution speed and the input torque. Besides, please make the driving wheel contact the roller of the test machine to use the loading method of the dynamometer of the test machine to measure the driving speed and the wheel driving force.

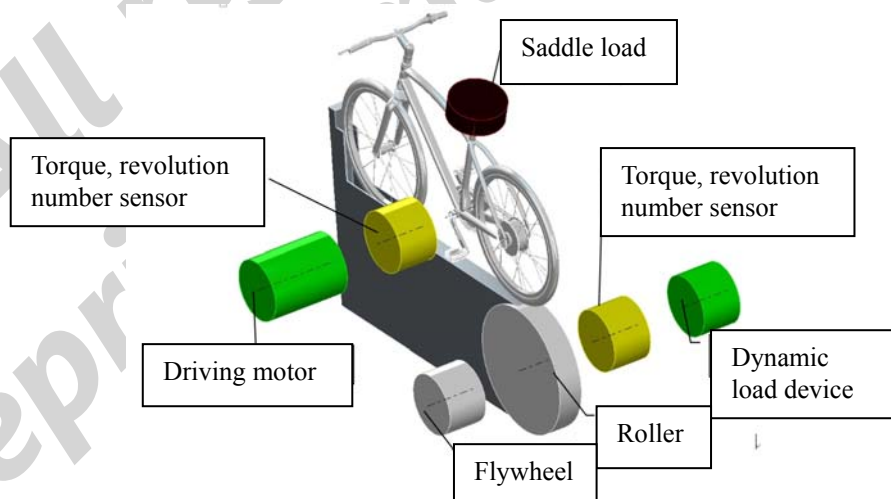

Figure L1 Concept diagram of test machine

6.2 Set test load

The load for the test should be set as follows:

a) Setting condition 1

Table 1 Load condition on slowly ascending slope

Test number	Targeted driving speed	Targeted wheel driving force
1	5 km/h	30 N
2	10 km/h	33 N
3	V1 km/h	F1 N
4	V2 km/h	F2 N
5	24 km/h	52 N
6	28 km/h	60 N

Test No.3 and Test No.4: when performing the test, please randomly designate V1 and V2 within 11~23 km/h; F1 and F2 are based on Table 2.

Table 2 Targeted driving speed and targeted wheel driving force randomly designated for Test No.3 and Test No.4

Targeted driving speed	Targeted wheel driving force
11 km/h	34 N
12 km/h	35 N
13 km/h	36 N
14 km/h	37 N
15 km/h	38 N
16 km/h	40 N
17 km/h	41 N
18 km/h	42 N
19 km/h	44 N
20 km/h	45 N
21 km/h	47 N
22 km/h	49 N
23 km/h	50 N

b) Setting condition 2

Table 3 Load condition on rapidly ascending slope

Test number	Targeted driving speed	Targeted wheel driving force
7	5 km/h	55 N
8	10 km/h	58 N
9	V3 km/h	F3 N
10	V4 km/h	F4 N
11	24 km/h	77 N
12	28 km/h	85 N

Test No.9 and Test No.10: when performing the test, please randomly designate V3 and V4 within 11~23 km/h; F3 and F4 are based on Table 4.

Table 4 Targeted driving speed and targeted wheel driving force randomly designated for Test No.9 and Test No.10

Targeted driving speed	Targeted wheel driving force
11 km/h	59 N
12 km/h	60 N
13 km/h	61 N
14 km/h	62 N
15 km/h	63 N
16 km/h	64 N
17 km/h	65 N
18 km/h	67 N
19 km/h	68 N
20 km/h	70 N
21 km/h	72 N
22 km/h	73 N
23 km/h	75 N

7. The test should be performed according to the following order:

The test is to install the bicycle on the test machine, and connect the crank of the bicycle to the external crank driving device, and then perform the test according to the

order of the setting condition 1 and the setting condition 2.

- a) Turn on the switch of the driving assistance device for testing the bicycle.
- b) Turn on the crank driving device to make the driving speed conform to the target value.
- c) Increase the load of the dynamometer of the test machine to make the driving force of the wheel conform to the target value.
- d) Confirm the driving speed and the wheel driving force to the allowable range of the target values.
- e) Measure the power consumption of the test machine after performing the test according to the setting condition 1 and the setting condition 2.
- f) Calculate the assistant force ratio of each test number according to each of the calculation equations.

Annex N

Climate tests for electrically power assisted bicycles

1. Scope

The test methods to determine the effects of condensation and the effects of changes of temperature on the basic functioning of electrically power assisted bicycles.

2. Standard ambient conditions

Environmental conditions of $20\text{ °C} \pm 5\text{ °C}$ and relative humidity of $60\% \pm 20\%$

3. Test methods

3.1 General

Conduct the tests specified in 3.3 to 3.7 in the following sequence:

3.2 Requirements

The electrically power assisted bicycles shall continue to function according to the manufacturer's specifications after being subjected to each of the tests specified in Sections 3.3 to 3.7

When the electrically power assisted bicycles is tested as specified in Clause 3.3 to 3.7:

- (a) it shall meet the requirements of the functional check specified in Section 4;
- (b) no driven part shall exhibit unintended movement during exposure to the specified test conditions.

2.3 Cold operating conditions

- (a) Store the electrically power assisted bicycle for not less than 20 h in standard ambient conditions with the electrically power assisted bicycle switched off.
- (b) Carry out the functional check specified in Section 4.
- (c) Leaving the electrically power assisted bicycle switched on, subject it to a temperature of -25_{-5}^{+2} °C for not less than 3 h.
- (d) Inspect the electrically power assisted bicycle for evidence that any driven part has moved.
- (e) Within 5 min, after completing the functional test in (d).

3.4 Hot operating conditions

- (a) Store the electrically power assisted bicycle for not less than 20 h in standard ambient conditions with the electrically power assisted bicycle

switched off.

- (b) Carry out the functional check specified in Section 4.
- (c) Leaving the electrically power assisted bicycle switched on, subject it to a temperature of 50^{+5}_{-2} °C for not less than 3 h.
- (d) Inspect the electrically power assisted bicycle for evidence that any driven part has moved .
- (e) Within 5 min, after completing the functional test in (d).

3.5 Cold storage conditions

- (a) Store the electrically power assisted bicycle for not less than 20 h in standard ambient conditions with the electrically power assisted bicycle switched off.
- (b) Carry out the functional check specified in Section 4.
- (c) Remove the batteries from the electrically power assisted bicycle.
- (d) Subject the electrically power assisted bicycle to a temperature of (-40 ± 5) °C for not less than 5 h.
- (e) Store the wheelchair for $1 \text{ h} \pm 5 \text{ min}$ in standard ambient conditions.
- (f) Replace the batteries removed in c).
- (g) Conduct the functional check specified in Sections 4 commencing within 5 min of completion of e).

3.6 Hot storage conditions

- (a) Store the electrically power assisted bicycle for not less than 20 h in standard ambient conditions with the electrically power assisted bicycle switched off.
- (b) Carry out the functional check specified in Sections 4.
- (c) Switch off the electrically power assisted bicycle.
- (d) Subject the electrically power assisted bicycle to a temperature of (65 ± 5) °C for not less than 5 h.
- (e) Inspect the electrically power assisted bicycle for evidence that any driven part has moved.
- (f) Store the electrically power assisted bicycle for $1 \text{ h} \pm 5 \text{ min}$ in standard ambient conditions.

- (g) Conduct the functional check specified in Clause 4 commencing within 5 min of completion of f).

3.7 Humidity and hot conditions

- (a) Store the electrically power assisted bicycle for not less than 20 h in standard ambient conditions with the electrically power assisted bicycle switched off.
- (b) Carry out the functional check specified in Section 4.
- (c) Leaving the electrically power assisted bicycle switched on, subject it to a temperature of $40^{\circ}\text{C}\pm 2^{\circ}\text{C}$ and humidity 93% for not less than 96 h.
- (d) Inspect the electrically power assisted bicycle for evidence that any driven part has moved.
- (e) Conduct the functional check specified in Clause 4 commencing within 5 min of completion of d).

4. Functional check

The function check is to determine that the power assisted function can be started normally after the power and power assisted modes of the electrically power assisted bicycle are turned on before and after the environmental conditions test in Sections 3.3 to 3.7 is performed.